

TC Electronic A/S		Designer HJE
Title GFLAT		Module title MAINBOARD
Number P22101_D	Revision DBB	Previous page XX
Date 6-30-2009 14:30	Filename P22101_D	Page / of 1 / 12

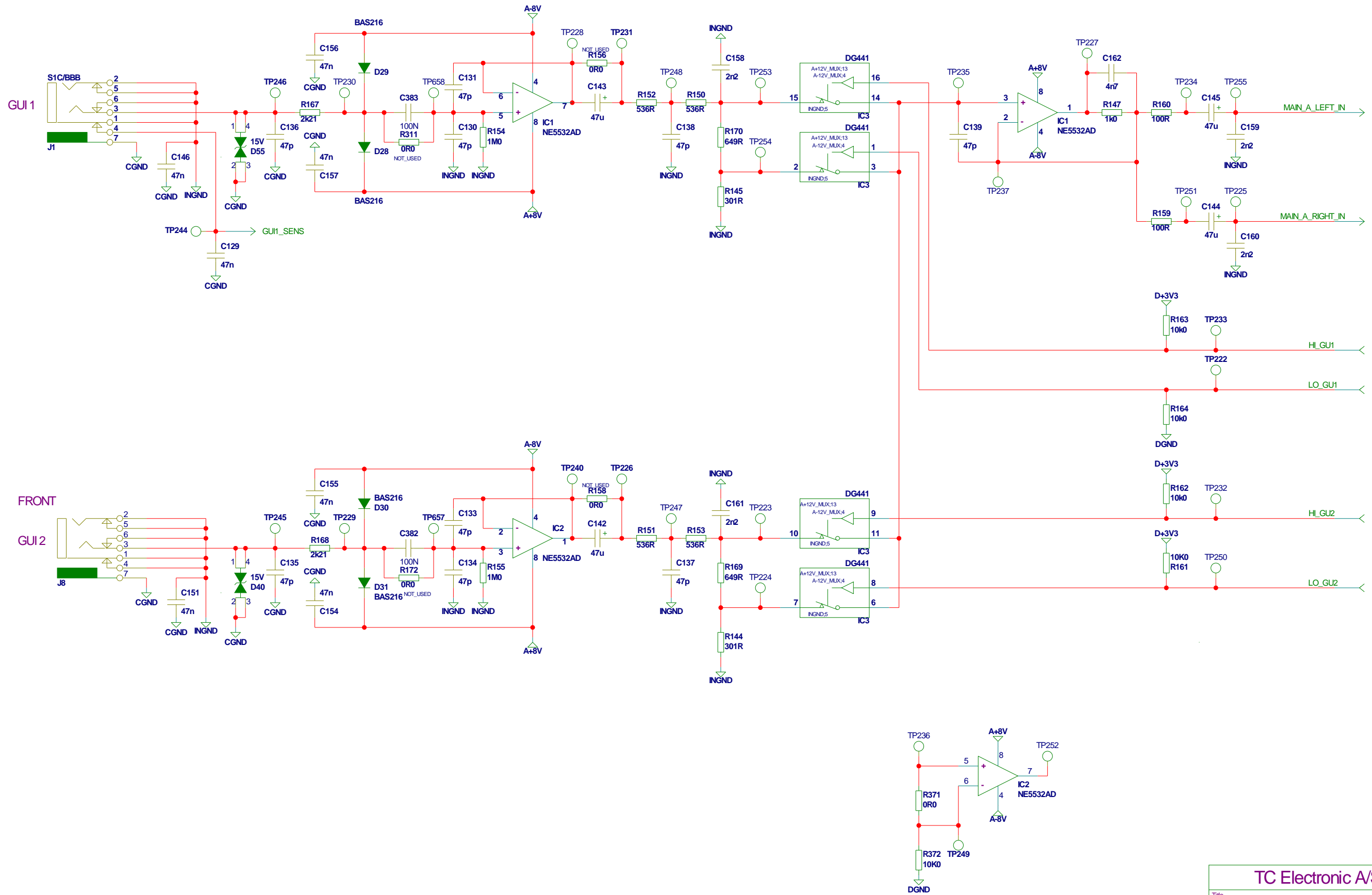

TC Electronic A/S		Designer HJE
Title GFLAT	Module title MAINBOARD	
Number P22101_D	Revision DBB	Previous page XX
Date 6-30-2009 14:32	Filename GUITAR_INPUT	Page / of 2 / 12

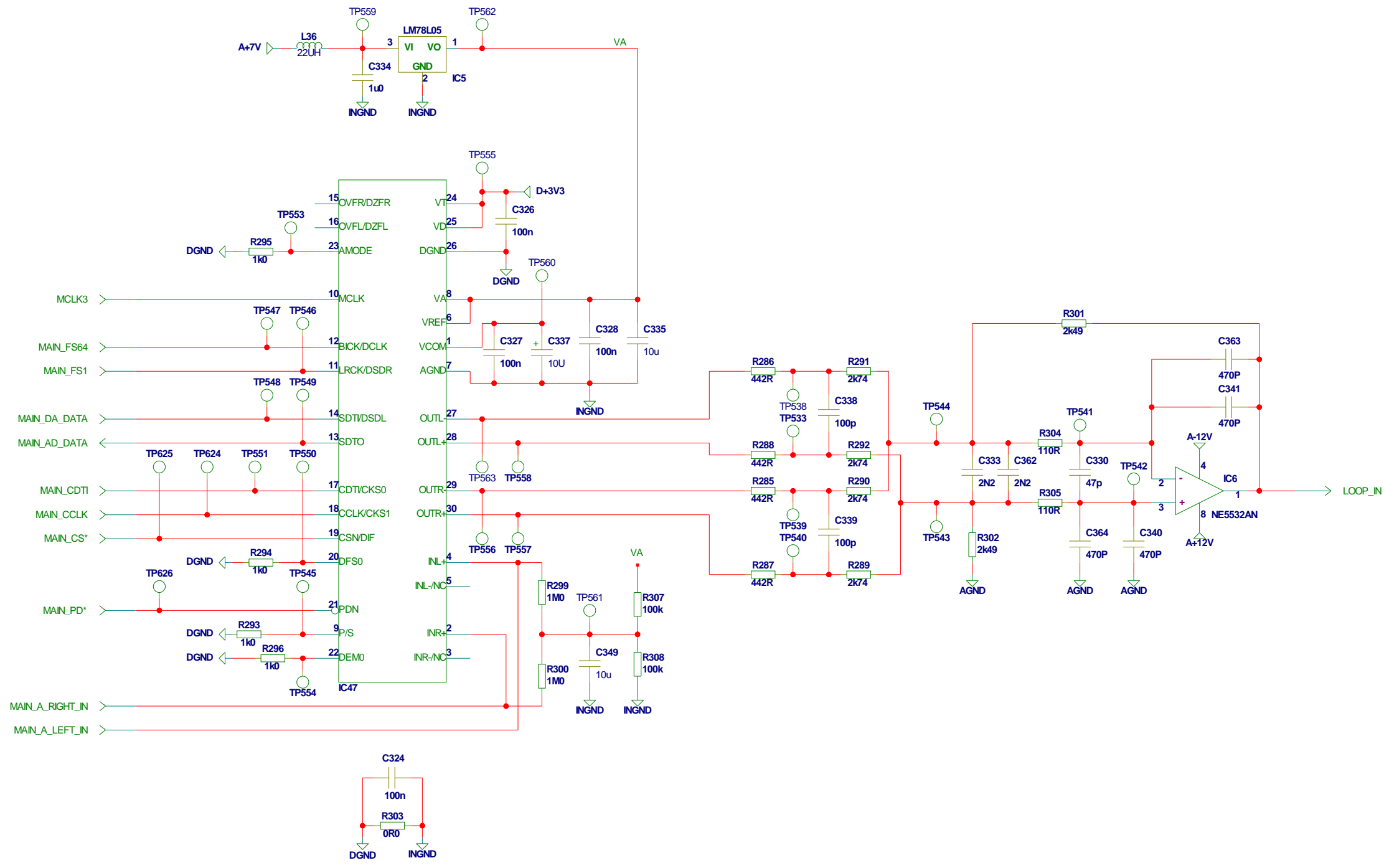

Title		Module title		Designer	
GFLAT		MAINBOARD		HJE	
Number	Revision	Previous page			
P22101_D	DBB	XX			
Date	Filename	Page / of			
6-30-2009 14:42	MAIN_CODEC	3 / 12			

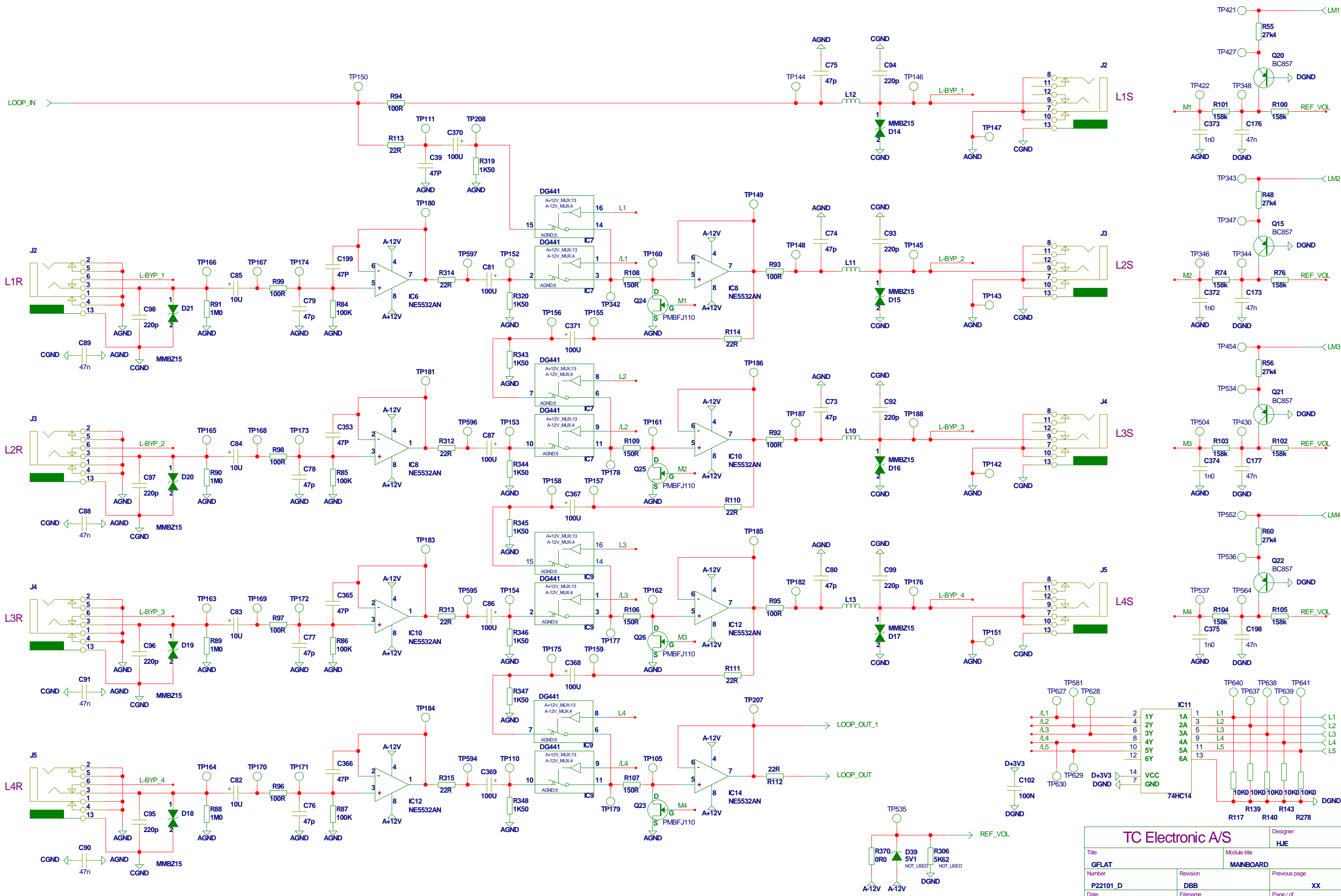

TC Electronic A/S		Designer	HJE
Title	GFLAT	Module title	MAINBOARD
Number	P22101_D	Revision	DBB
Date	6-30-2009 14:31	Filename	LOOPS
		Previous page	XX
		Page / of	4 / 12

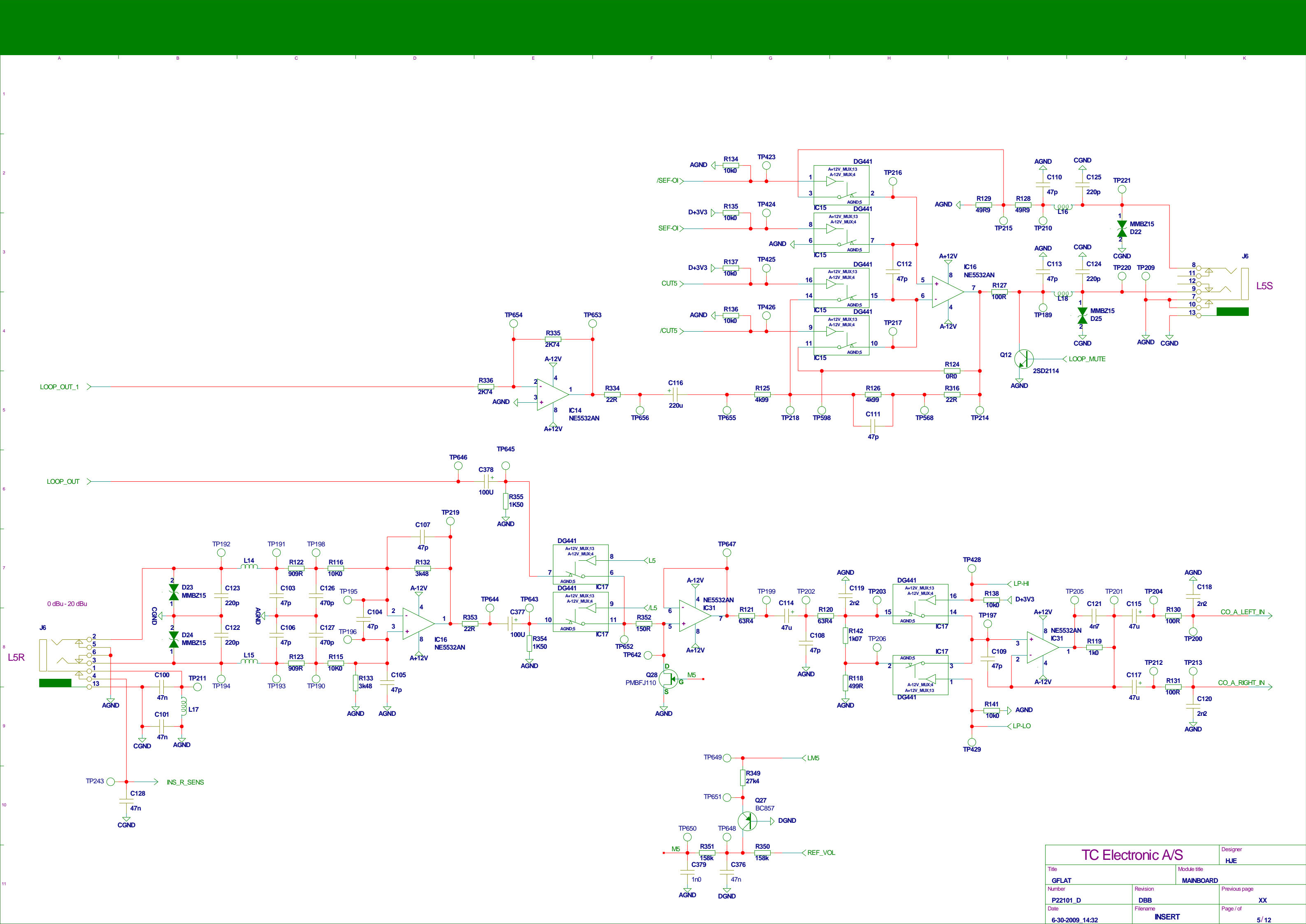

TC Electronic A/S		Designer	HJE
Title	GFLAT	Module title	MAINBOARD
Number	P22101_D	Revision	DBB
Date	6-30-2009 14:32	Filename	INSERT
		Previous page	XX
		Page / of	5 / 12

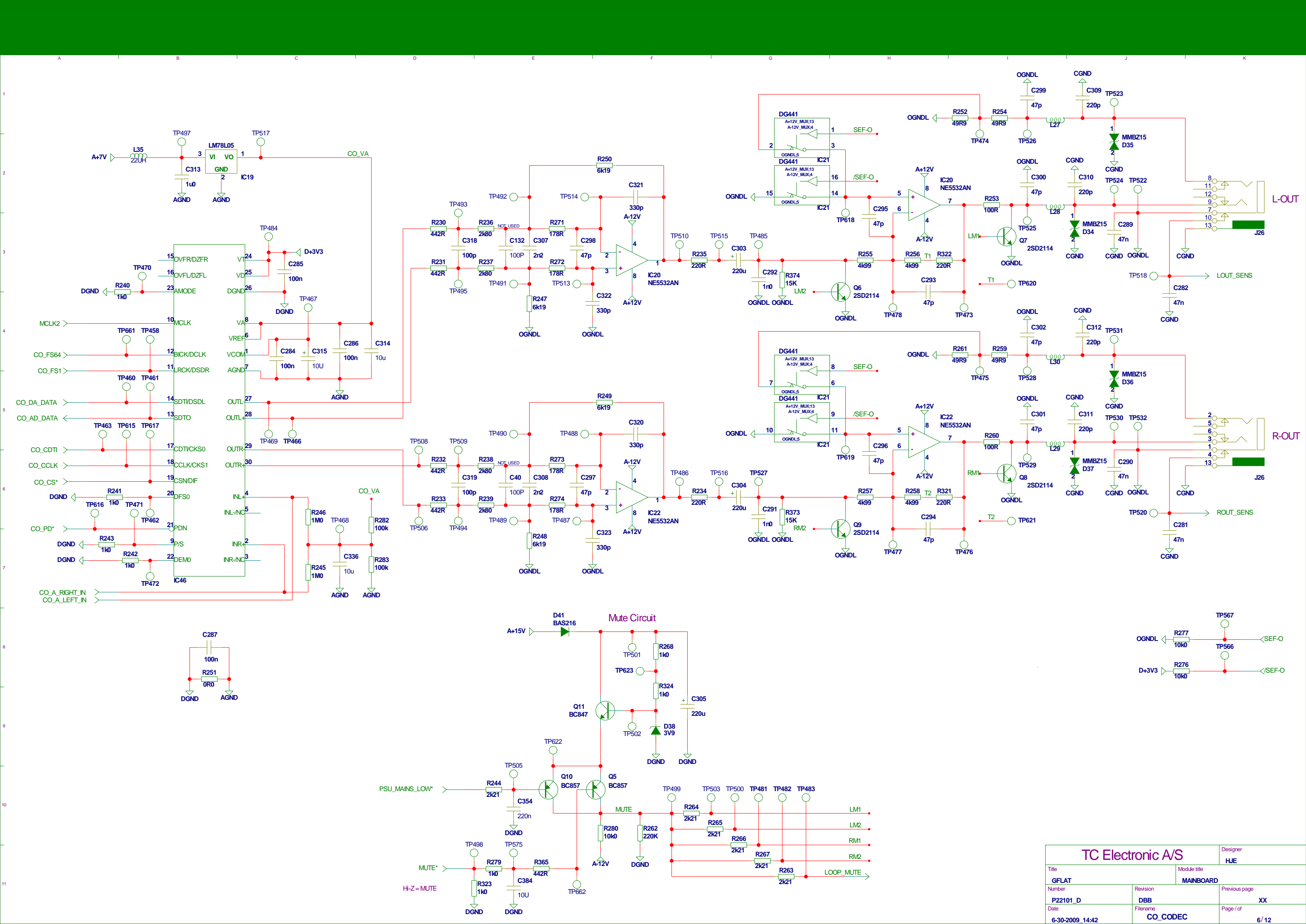

TC Electronic A/S		Designer	HJE
Title	GFLAT	Module title	MAINBOARD
Number	P22101_D	Revision	DBB
Date	6-30-2009 14:42	Filename	CO_CODEC
		Previous page	XX
		Page / of	6 / 12

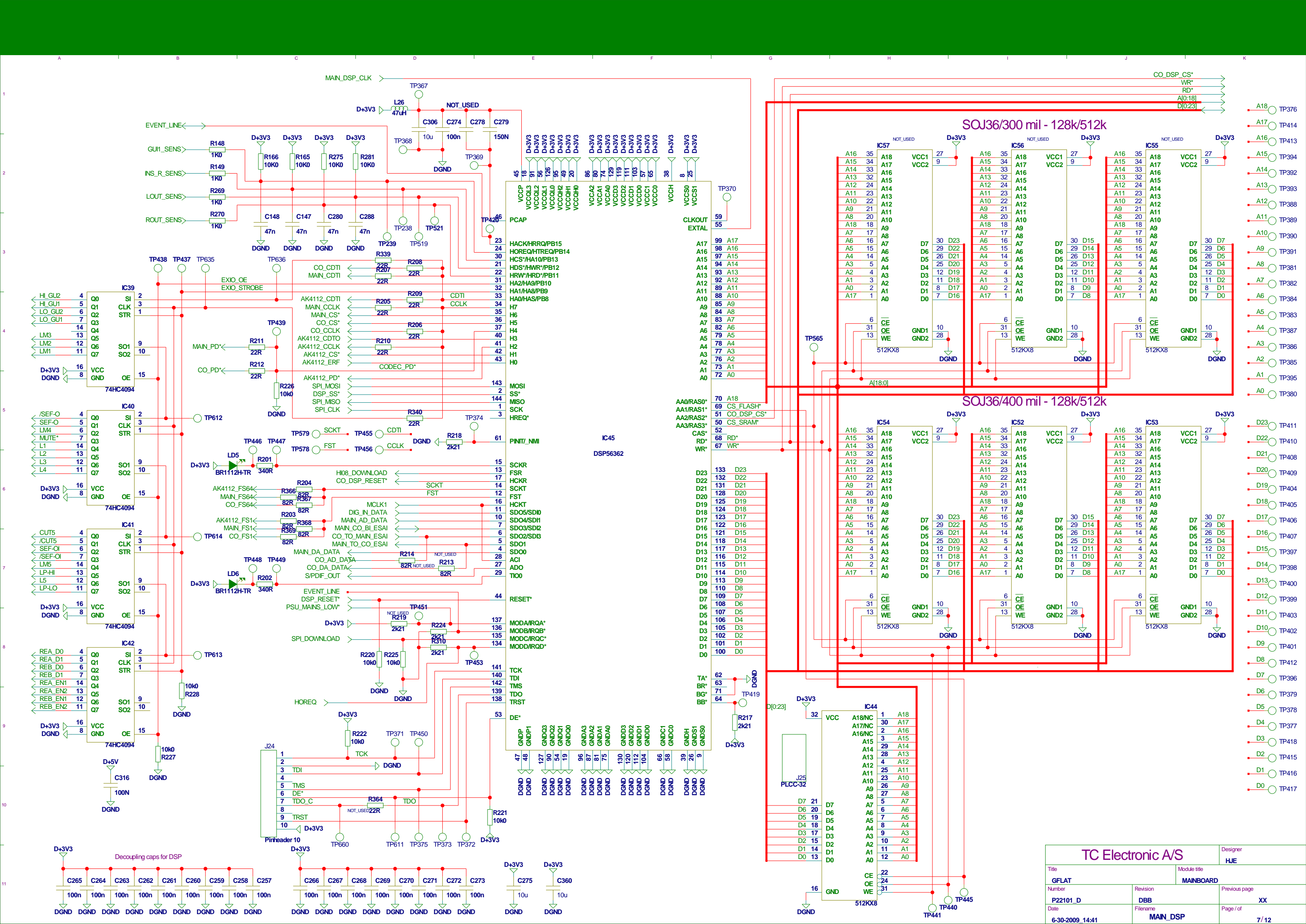

TC Electronic A/S		Designer	HJE
Title	GFLAT	Module title	MAINBOARD
Number	P22101_D	Revision	DBB
Date	6-30-2009 14:41	Filenam	MAIN_DSP
		Previous page	XX
		Page / of	7 / 12

- TP317 A1_18
- TP299 A1_17
- TP300 A1_16
- TP301 A1_15
- TP302 A1_14
- TP303 A1_13
- TP304 A1_12
- TP305 A1_11
- TP306 A1_10
- TP307 A1_9
- TP308 A1_8
- TP309 A1_7
- TP310 A1_6
- TP311 A1_5
- TP312 A1_4
- TP313 A1_3
- TP314 A1_2
- TP315 A1_1
- TP316 A1_0

- TP318 D1_23
- TP319 D1_22
- TP320 D1_21
- TP321 D1_20
- TP322 D1_19
- TP323 D1_18
- TP324 D1_17
- TP325 D1_16
- TP326 D1_15
- TP327 D1_14
- TP328 D1_13
- TP329 D1_12
- TP330 D1_11
- TP331 D1_10
- TP332 D1_9
- TP333 D1_8
- TP335 D1_6
- TP334 D1_7
- TP336 D1_5
- TP337 D1_4
- TP338 D1_3
- TP339 D1_2
- TP340 D1_1
- TP341 D1_0

SOJ36/300 mil - 128k/512k

SOJ36/400 mil - 128k/512k

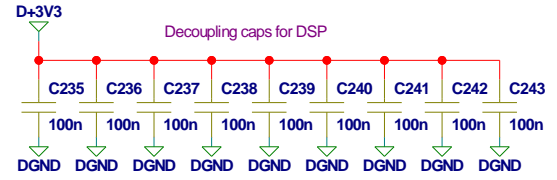
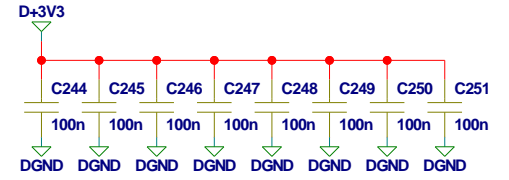
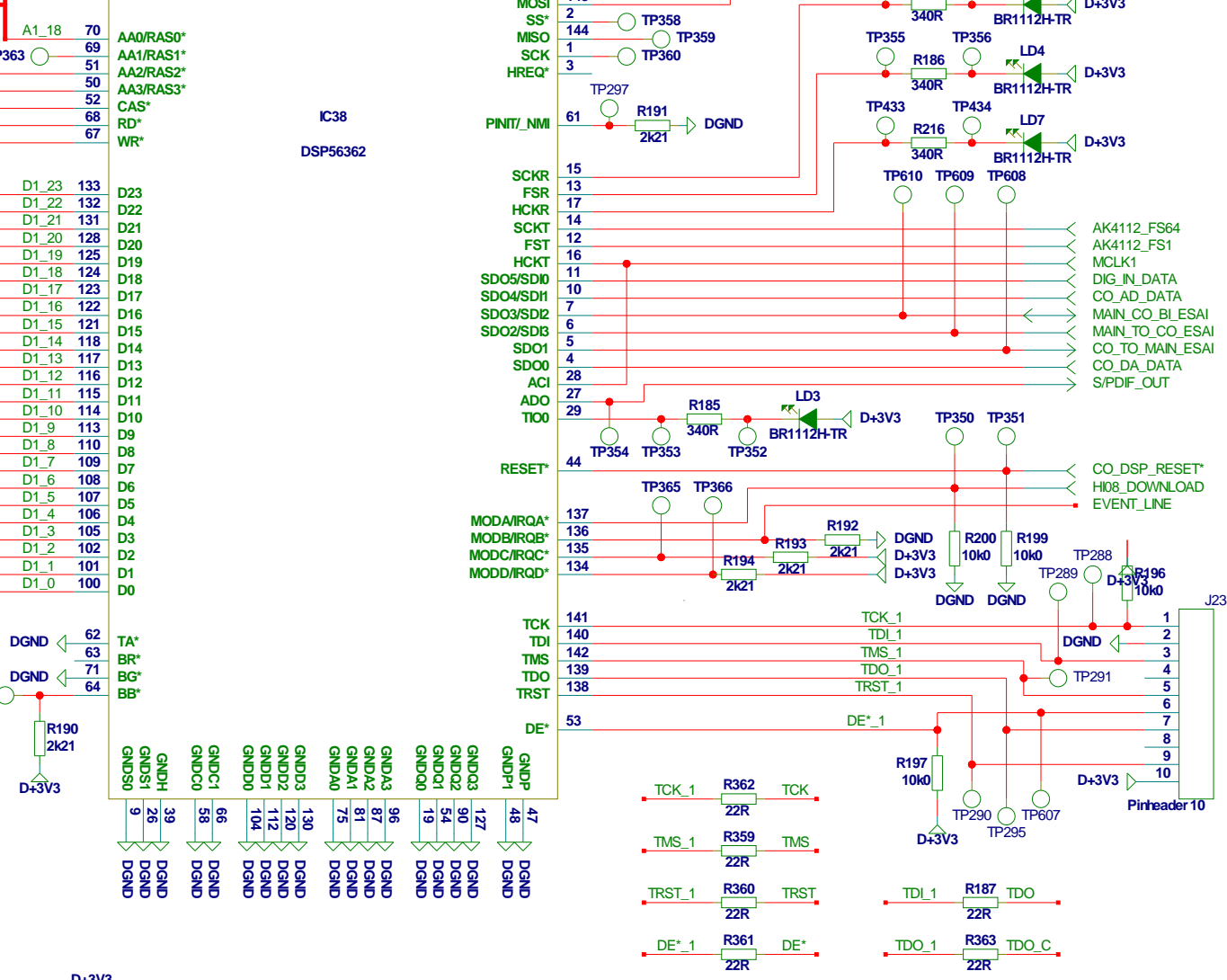
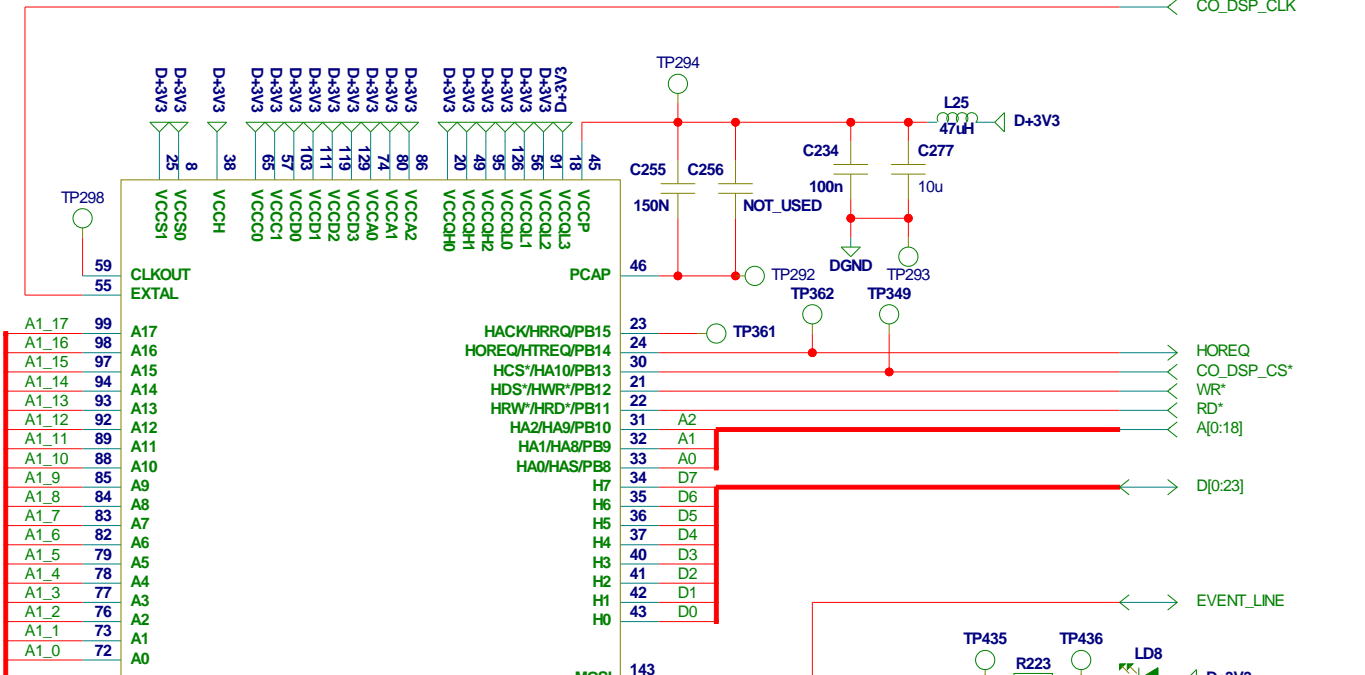
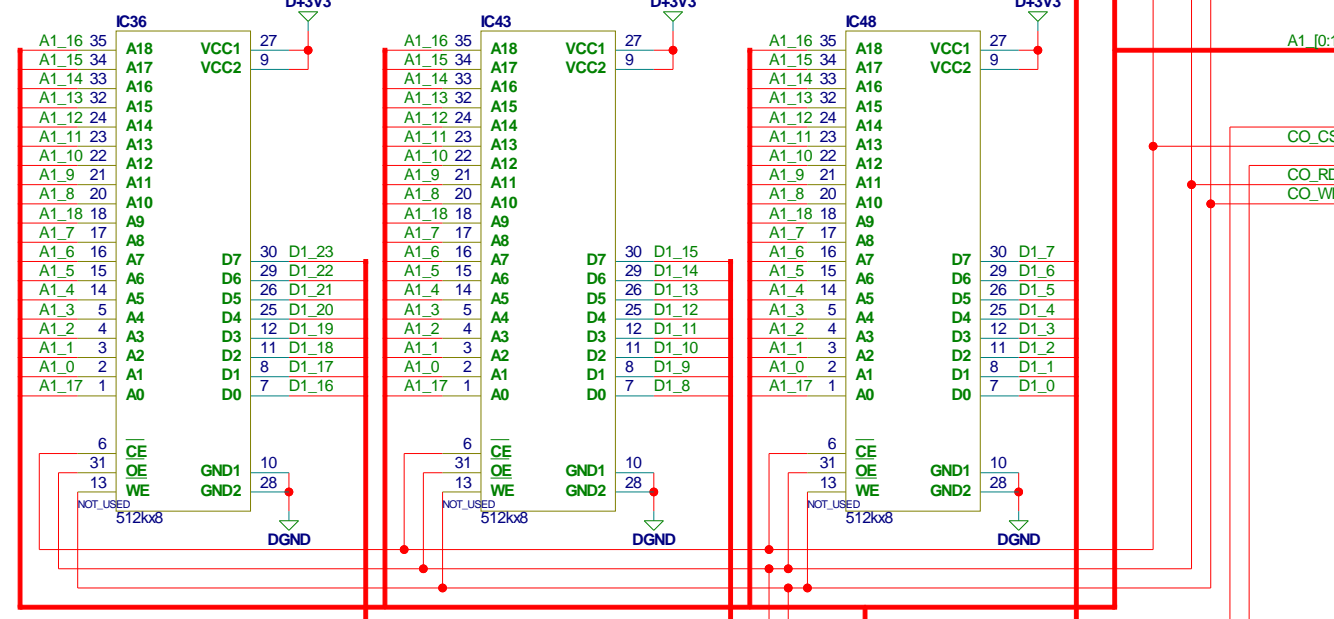
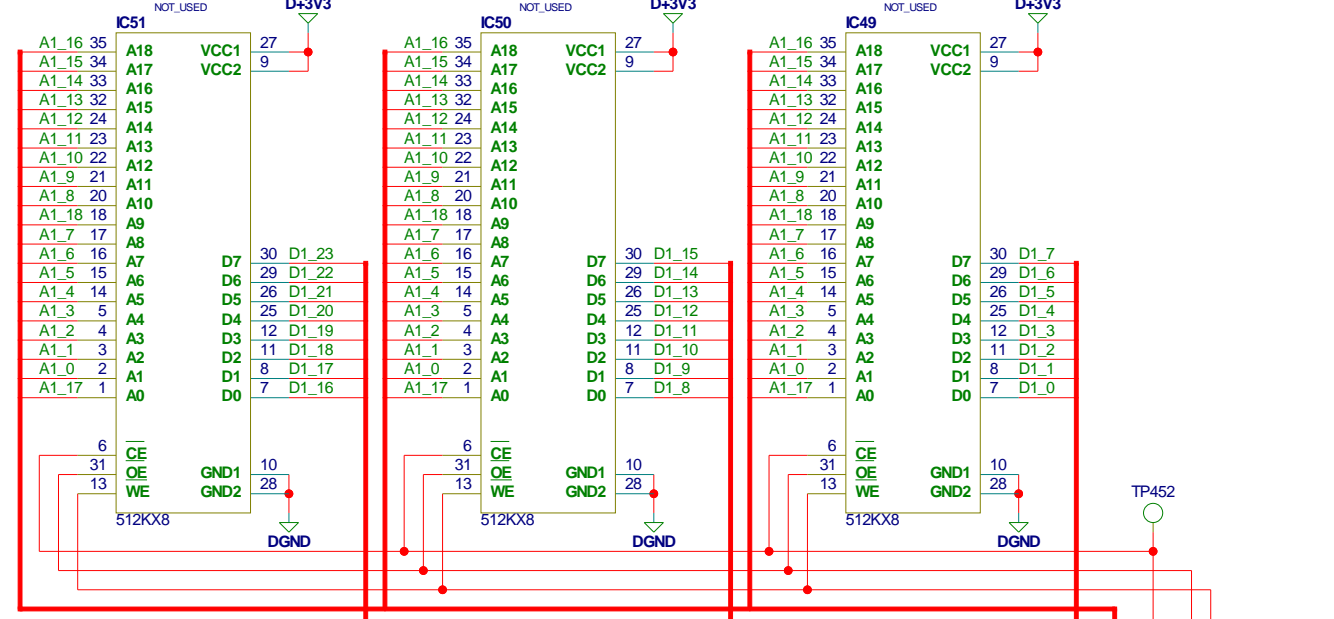

TC Electronic A/S		Designer	HJE
Title	GFLAT	Module title	MAINBOARD
Number	P22101_D	Revision	DBB
Date	6-30-2009 14:41	Filename	CO_DSP
		Previous page	XX
		Page / of	8 / 12

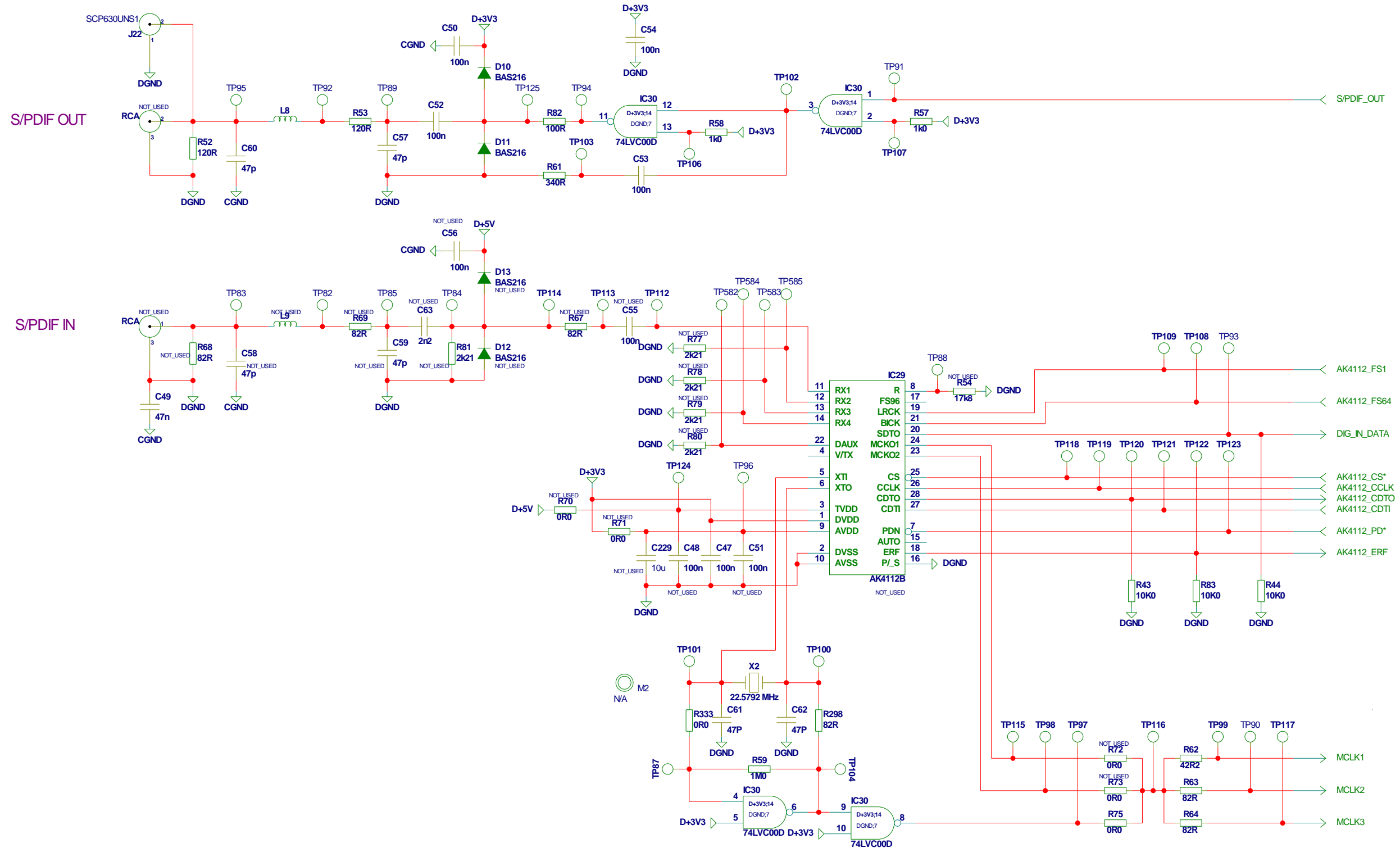

TC Electronic A/S		Designer HJE
Title GFLAT		Module title MAINBOARD
Number P22101_D	Revision DBB	Previous page XX
Date 6-30-2009 14:30	Filename DIGITAL_IN_OUT	Page / of 9 / 12

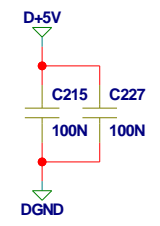
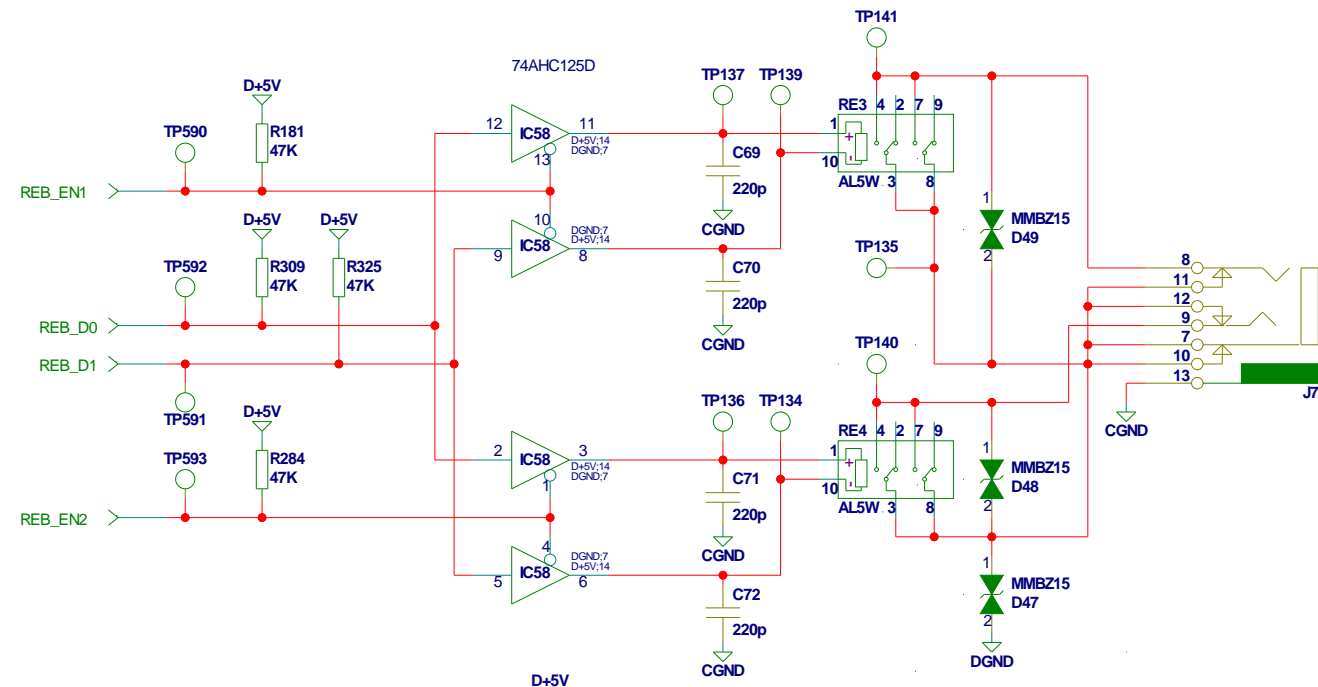
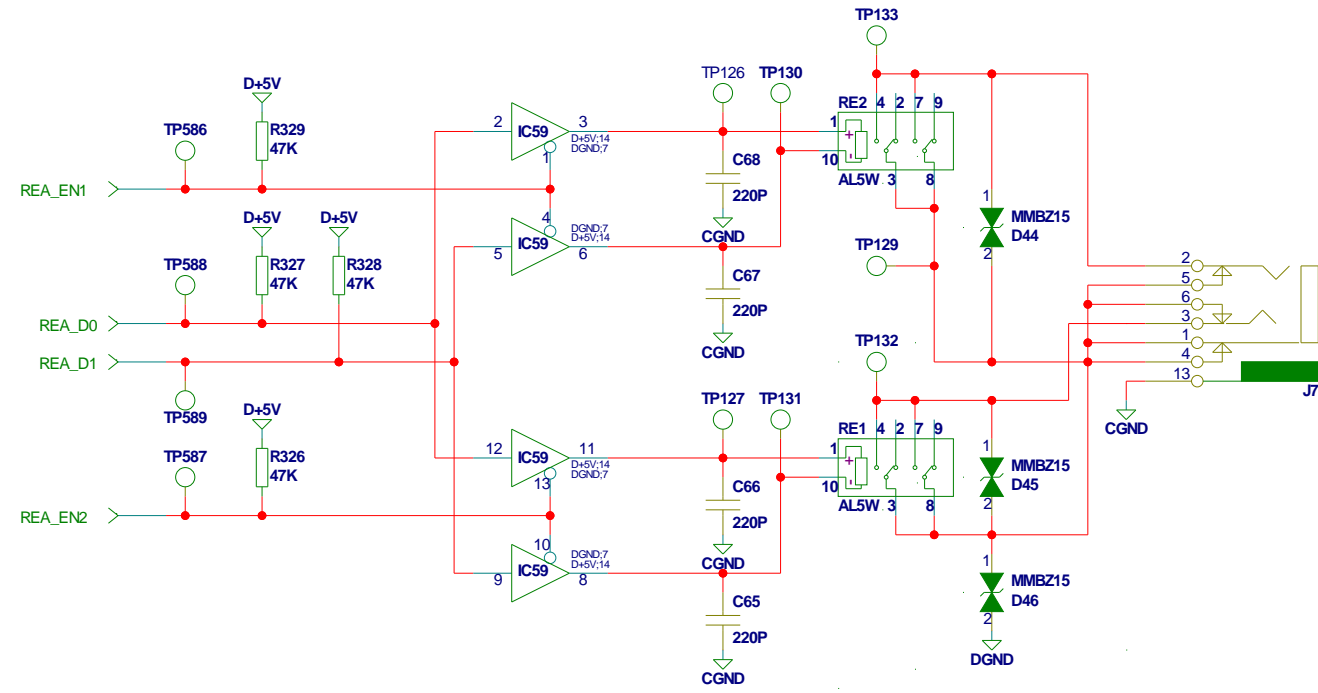

TC Electronic A/S		Designer HJE
Title GFLAT	Module title MAINBOARD	
Number P22101_D	Revision DBB	Previous page XX
Date 6-30-2009 14:31	Filename SWITCHOUTPUTS	Page / of 10 / 12

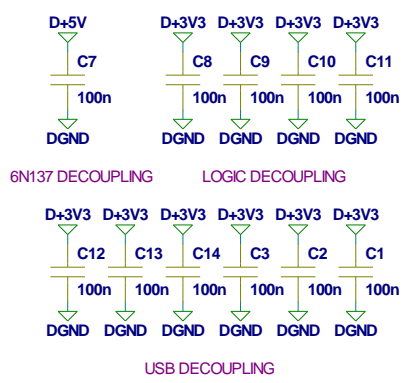
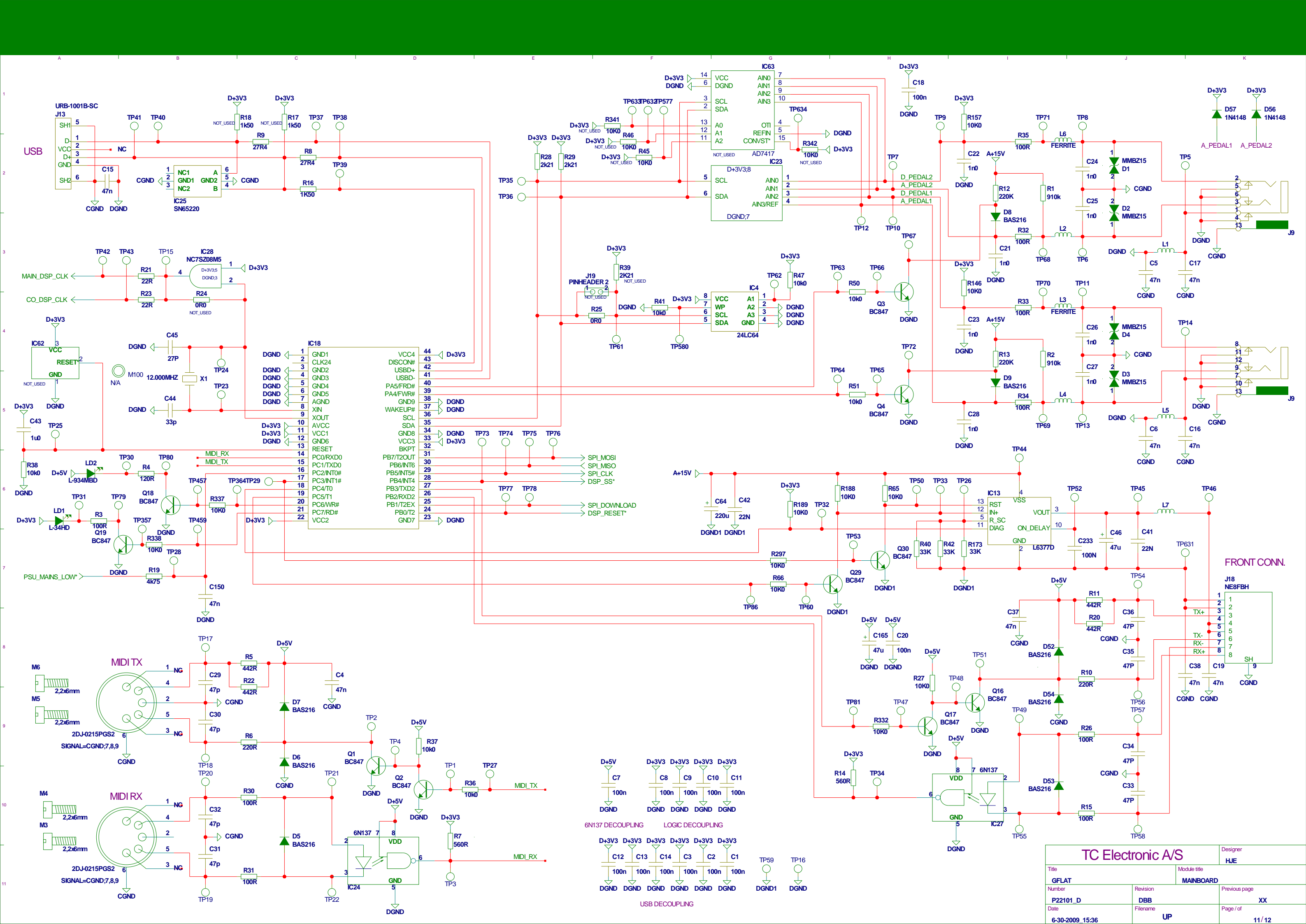

TC Electronic A/S		Designer	HJE
Title	GFLAT	Module title	MAINBOARD
Number	P22101_D	Revision	DBB
Date	6-30-2009 15:36	Filename	UP
		Previous page	XX
		Page / of	11 / 12

SMPS - CONNECTIONS

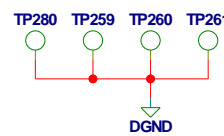
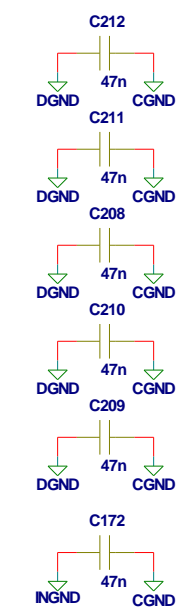
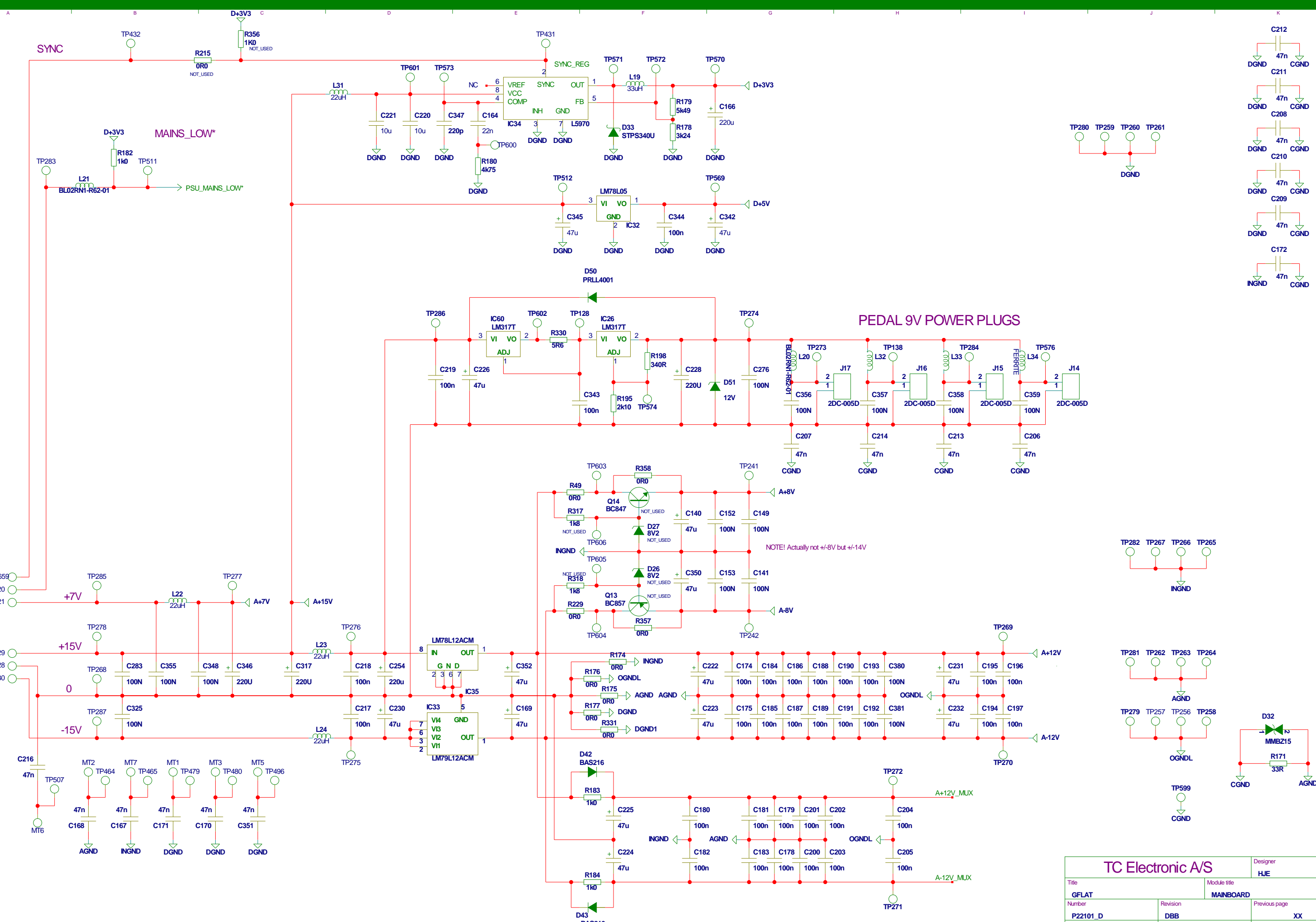

PEDAL 9V POWER PLUGS

NOTE! Actually not +/-8V but +/-14V

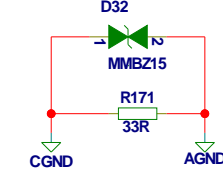
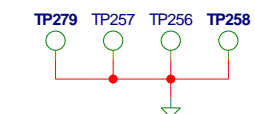
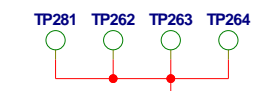
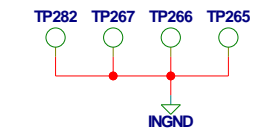

TC Electronic A/S		Designer	HJE
Title	GFLAT	Module title	MAINBOARD
Number	P22101_D	Revision	DBB
Date	6-30-2009 14:32	Filename	POWER
		Previous page	XX
		Page / of	12 / 12