

M1  
P22380-D

TC Electronic A/S		Designer HJE/PRO
Title BLUEFIN	Module title OVERVIEW	
Number P22380	Revision DAC	Previous page XX
Date 12-2-2009 19:20	Filename P22380-D	Page / of 1 / 4

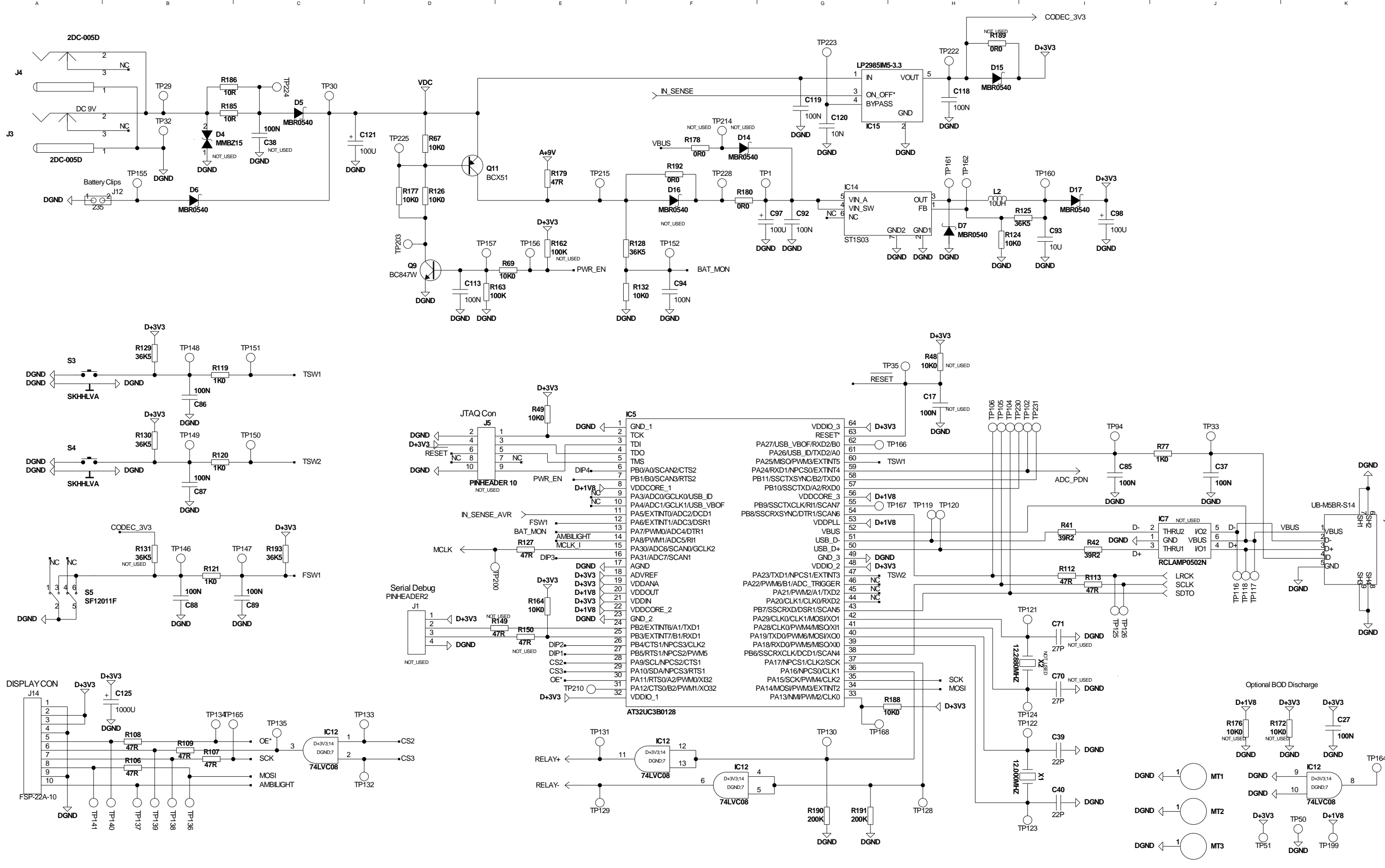

<b>TC Electronic A/S</b> Title: BLUEFIN Number: P22380 Date: 12-2-2009_19:21		Designer: HJE/PRO Module title: MODULE TITLE Revision: DAC Filename: UC_AND_CONNECTS Page: 1 of 1
---	--	---

# True Bypass

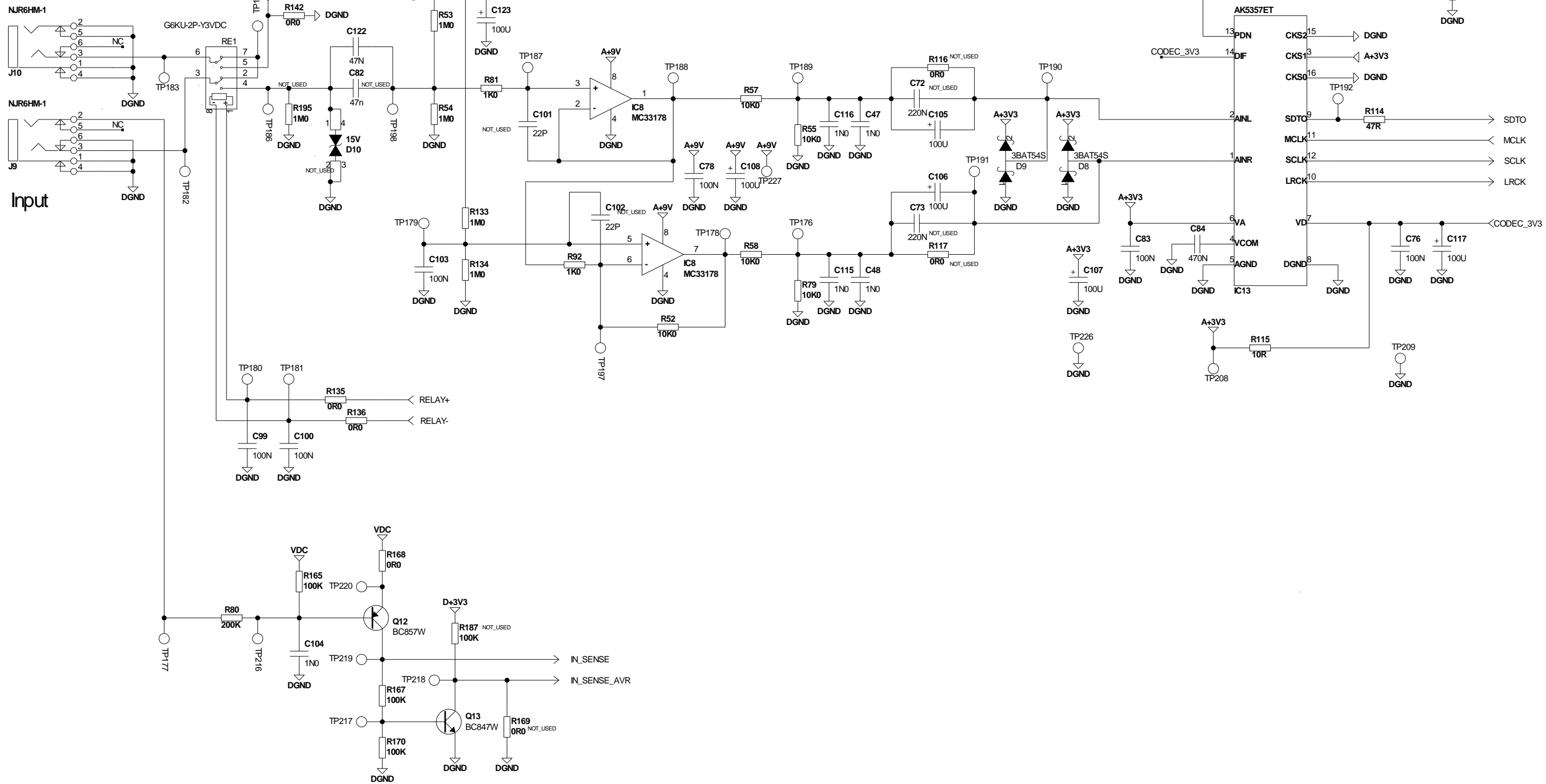

<b>TC Electronic A/S</b>		Designer HJE/PRO
Title BLUEFIN	Module title MODULE TITLE	
Number P22380	Revision DAC	Previous page 2
Date 12-2-2009_19:21	Filename INPUT	Page / of 3 / 4

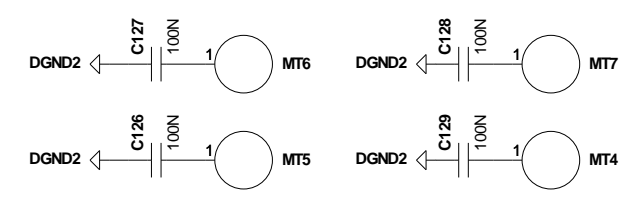
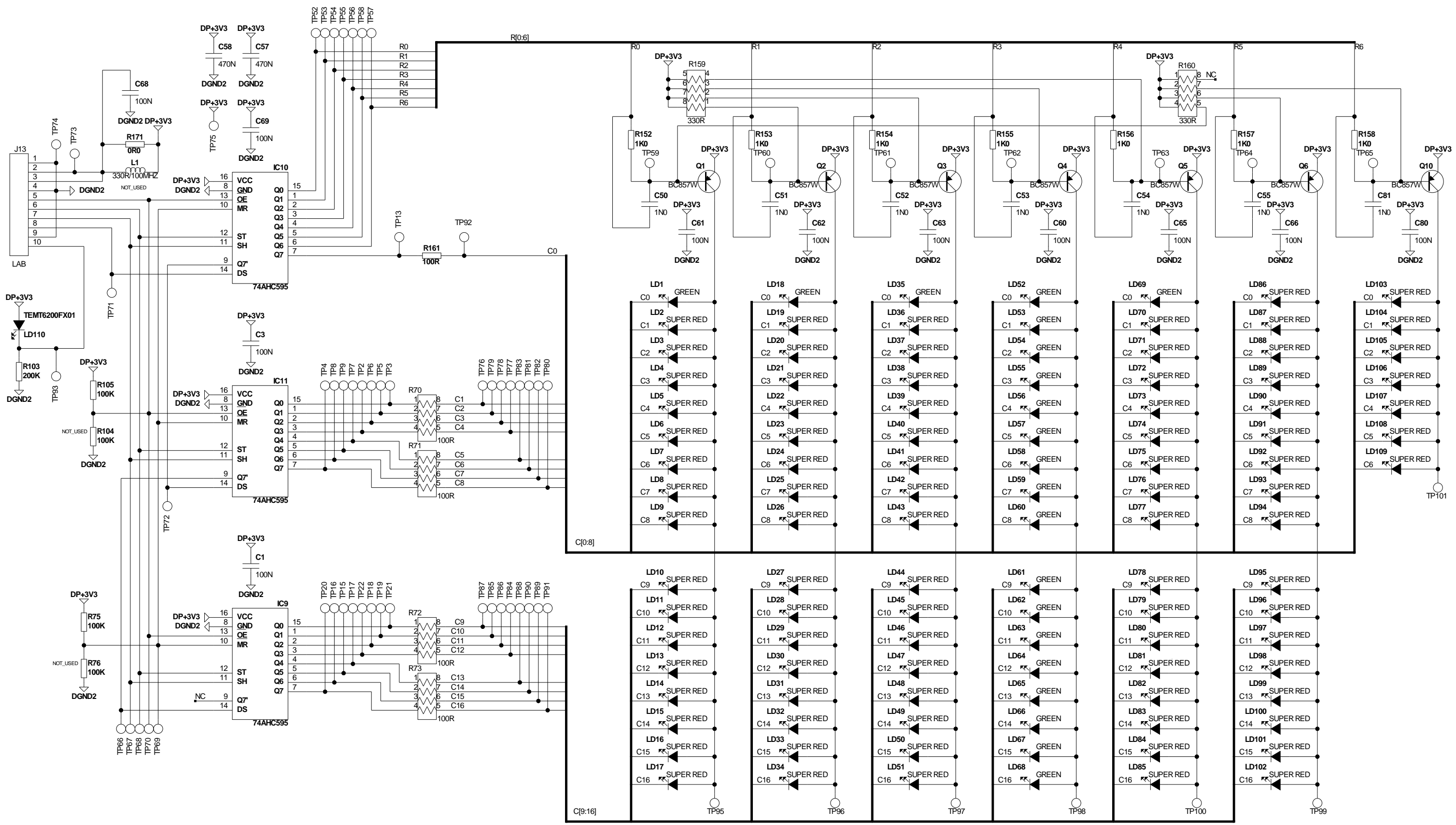

<b>TC Electronic A/S</b>		Designer HJE/PRO
Title BLUEFIN	Module title DISPLAY	
Number P22380	Revision DAC	Previous page 3
Date 12-2-2009_19:20	Filename LEDS_CONTROL	Page / of 4 / 4