

PCB  
M1  
P22384-B

				Designer(s) HJE/PRO	
Title 1278-DIAMONDLANE				Module title MODULE TITLE	
Number P22384	Revision B	Variant A	Version B	Board type MAINBOARD	
Date 09/01/2015:17:30	Filename			Page / of 1 / 7	

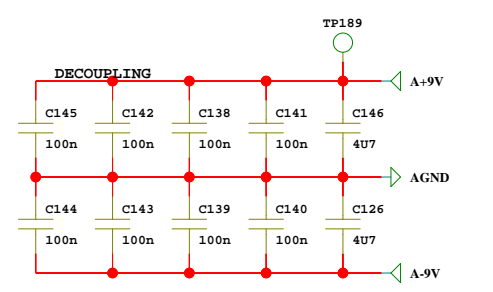
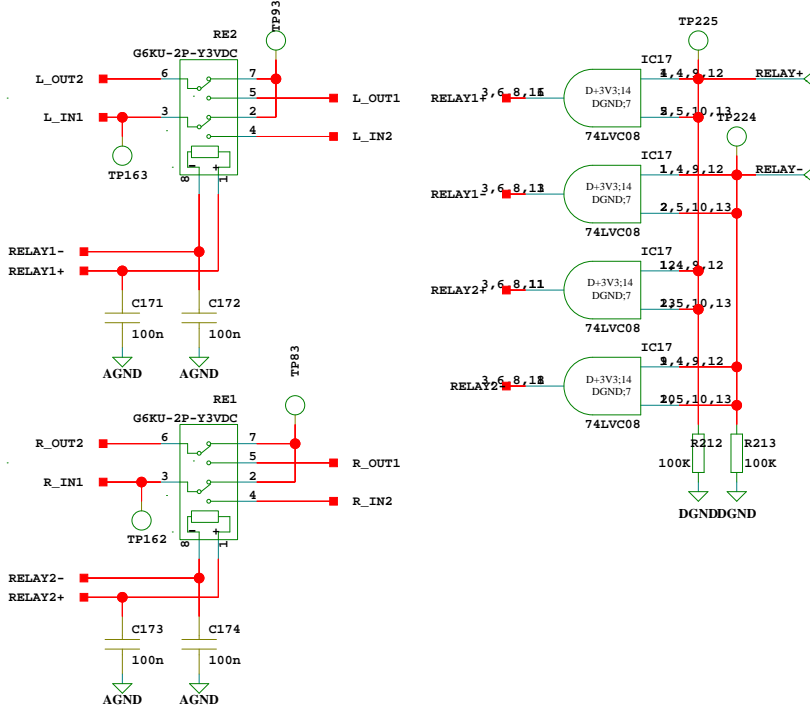
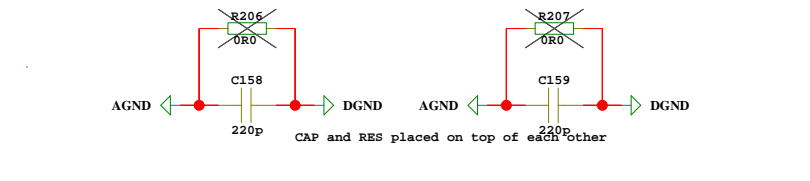
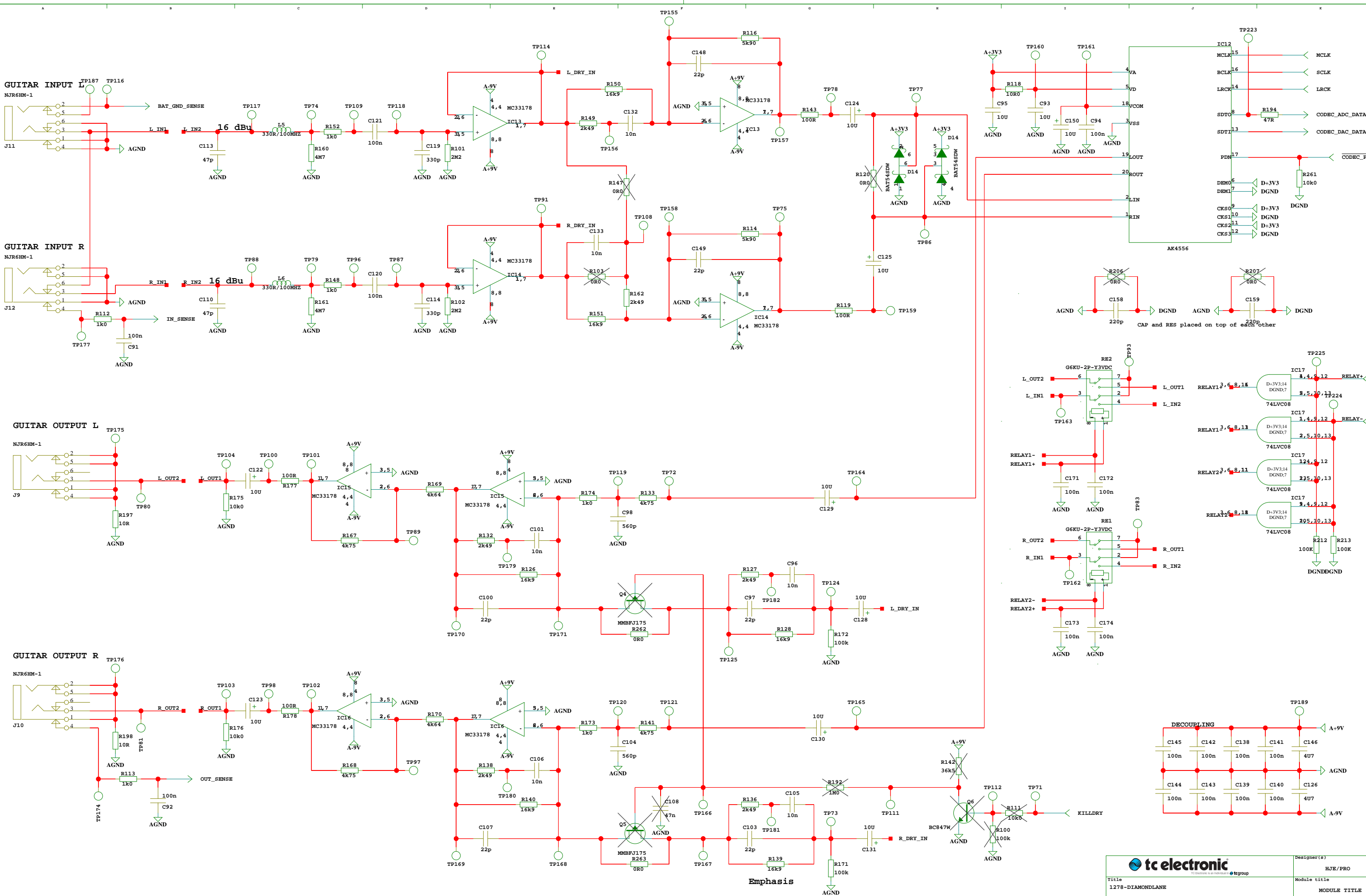

Emphasis

				Designer(s)	
				HJE/PRO	
Title				Module title	
1278-DIAMONDLANE				MODULE TITLE	
Number		Revision	Variant	Version	Board type
F22384		B	A	B	MAINBOARD
Date	Filename	Page / of			
09/01/2015:17:30	analog	6 / 7			

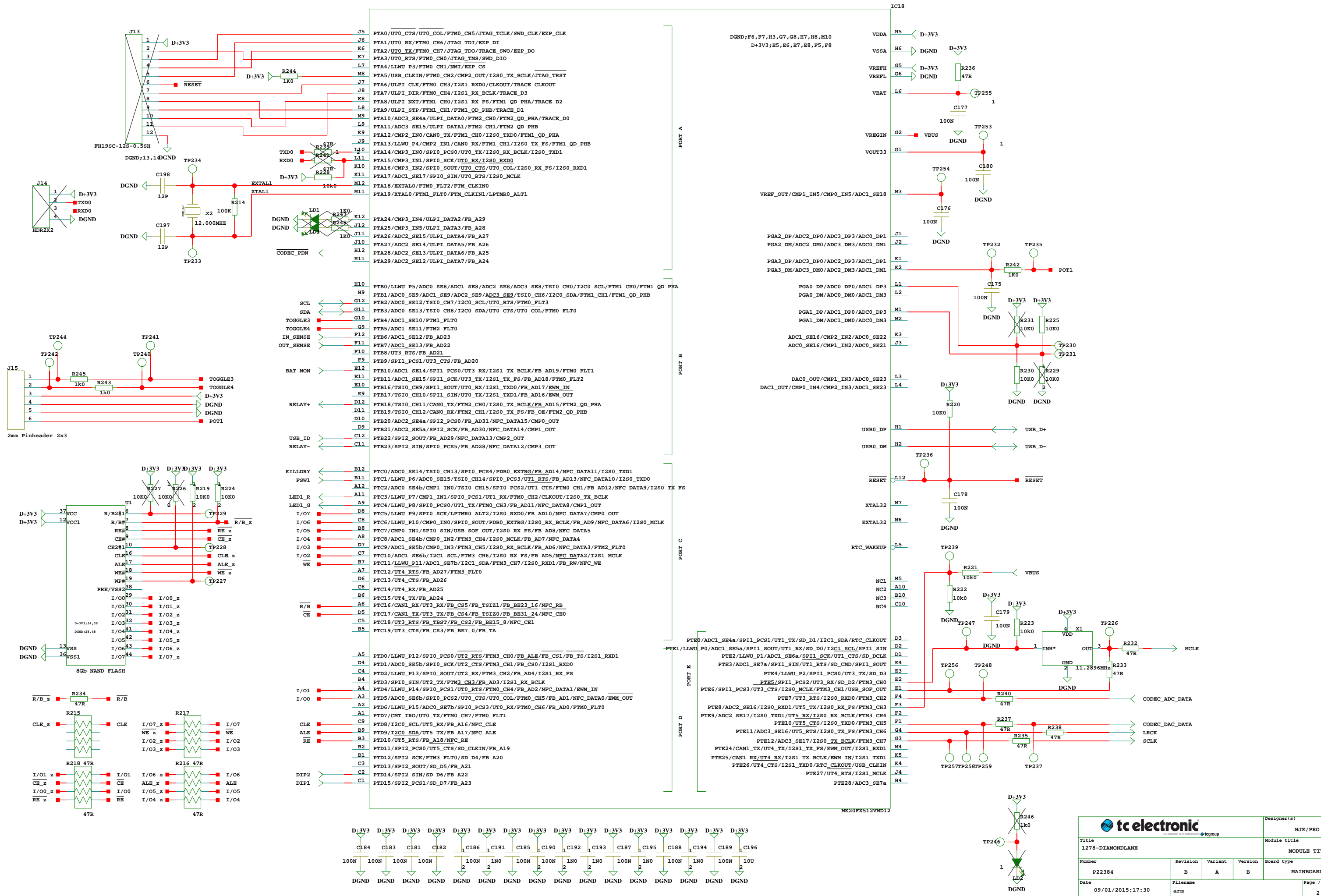

				Designer(s)	HJE/PRO
Title 1278-DIAMONDLANE				Module title	MODULE TITLE
Number	Revision	Variant	Version	Board type	
P22384	B	A	B	MAINBOARD	
Date	Filename	Page / of			
09/01/2015:17:30	arm	2 / 7			

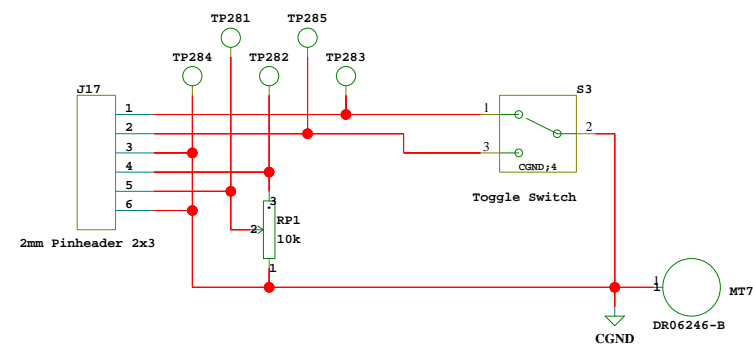

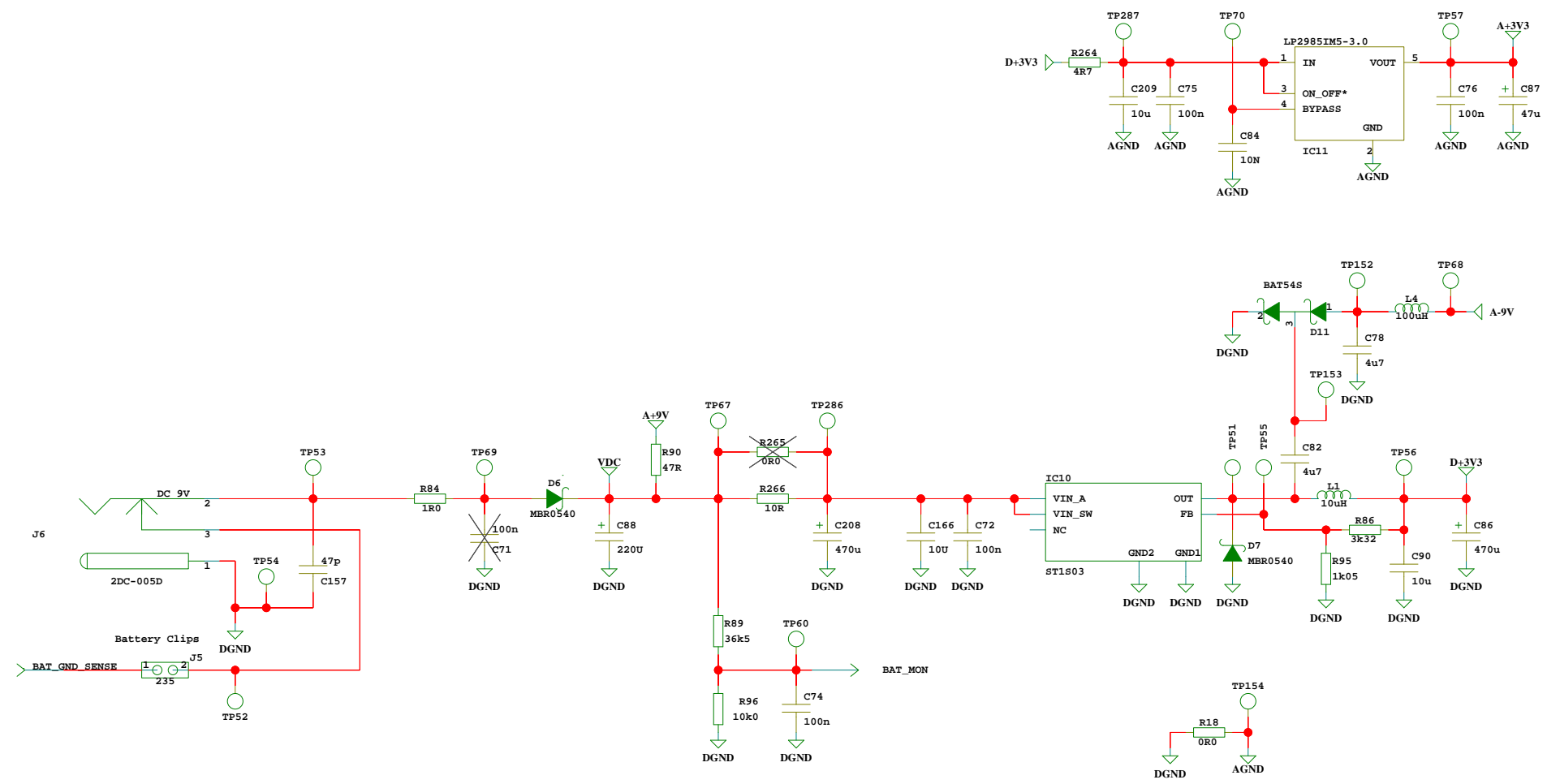

**SHORT R18, wide trace**

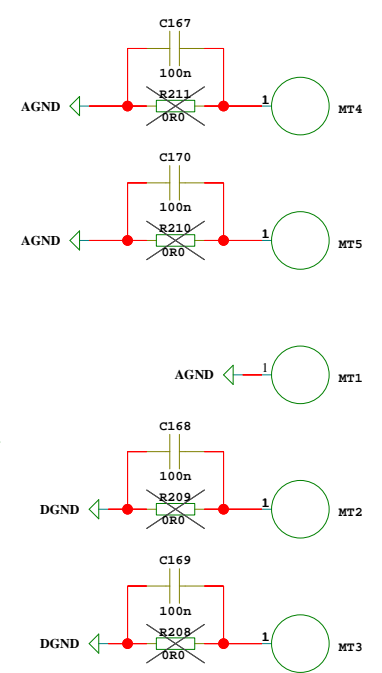

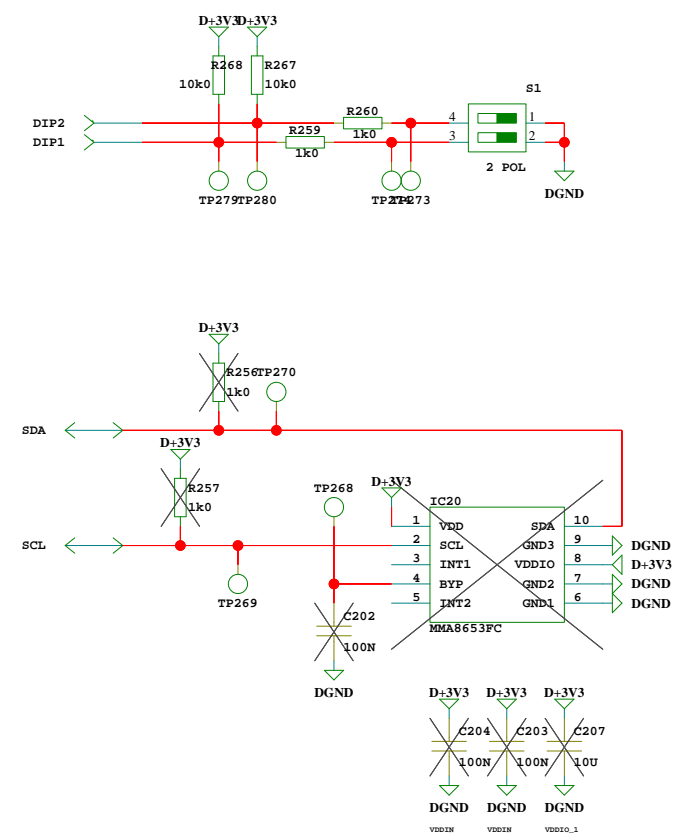
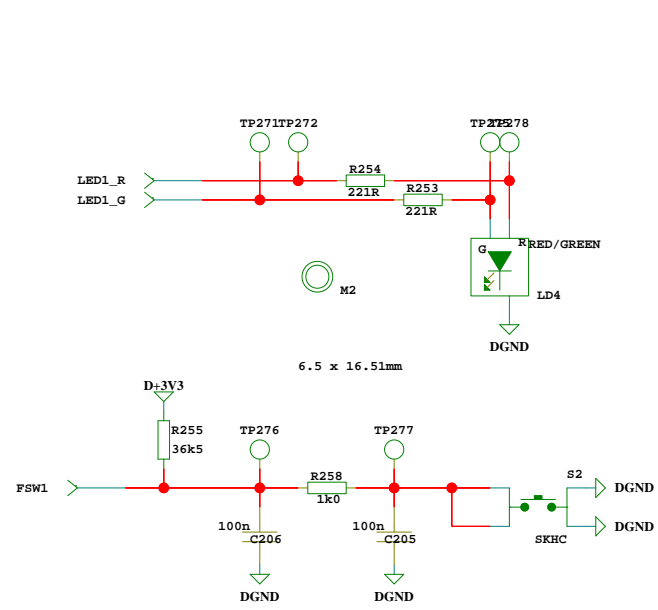

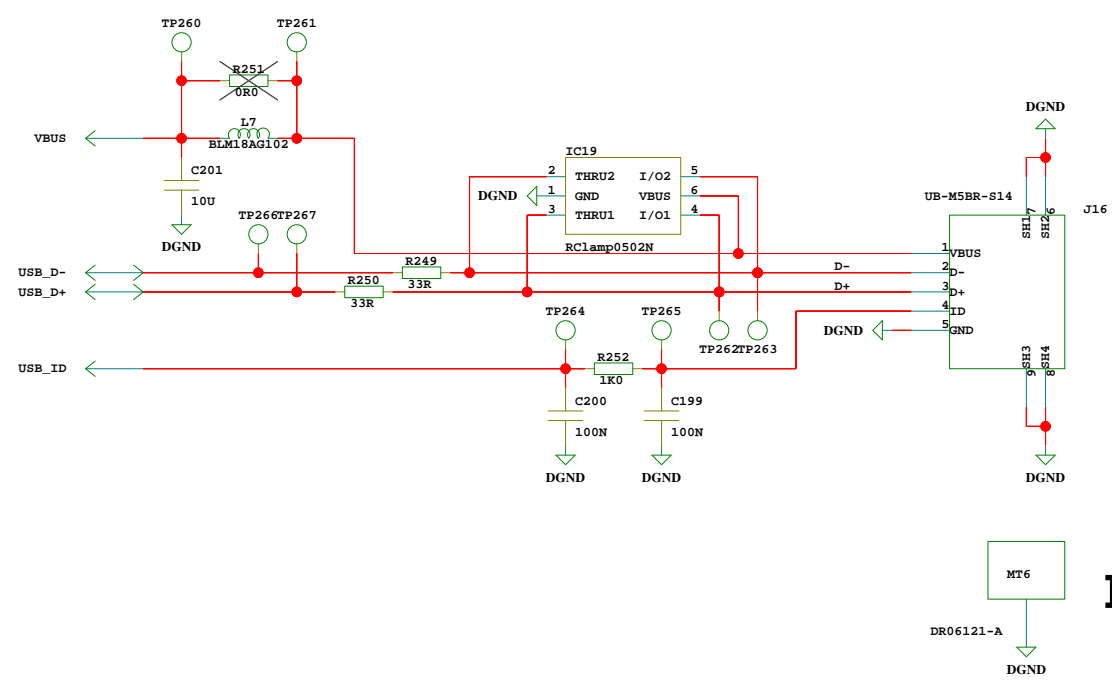

# EMI Clip decal

