

GUITAR\_INPUT

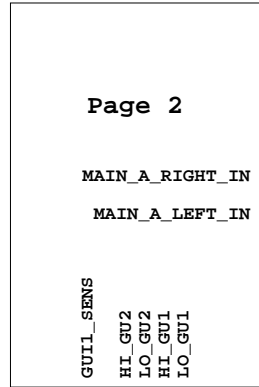

MAIN\_CODEC

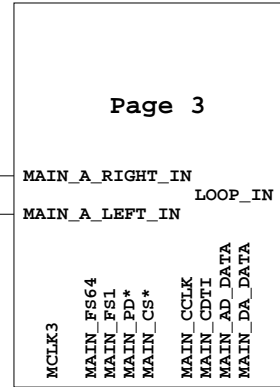

LOOPS

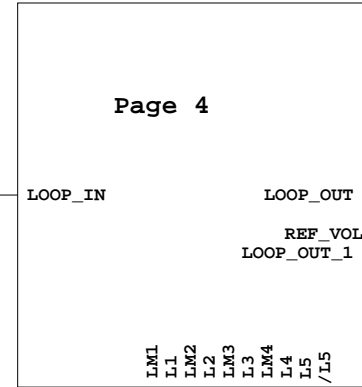

INSERT

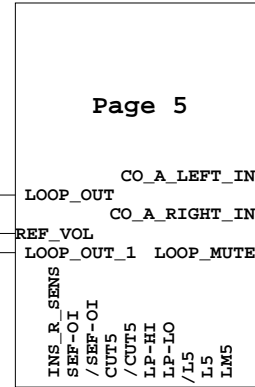

CO\_CODEC

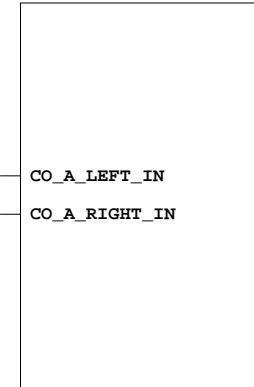

DIGITAL\_IN\_OUT

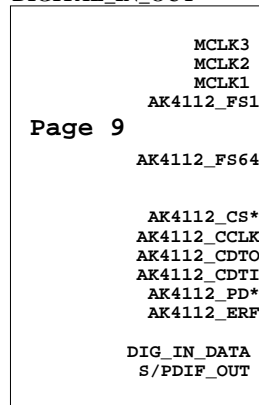

SWITCHOUTPUTS

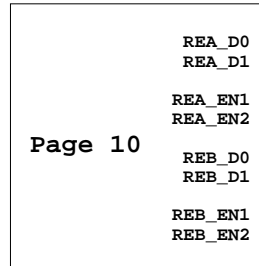

MAIN\_DSP

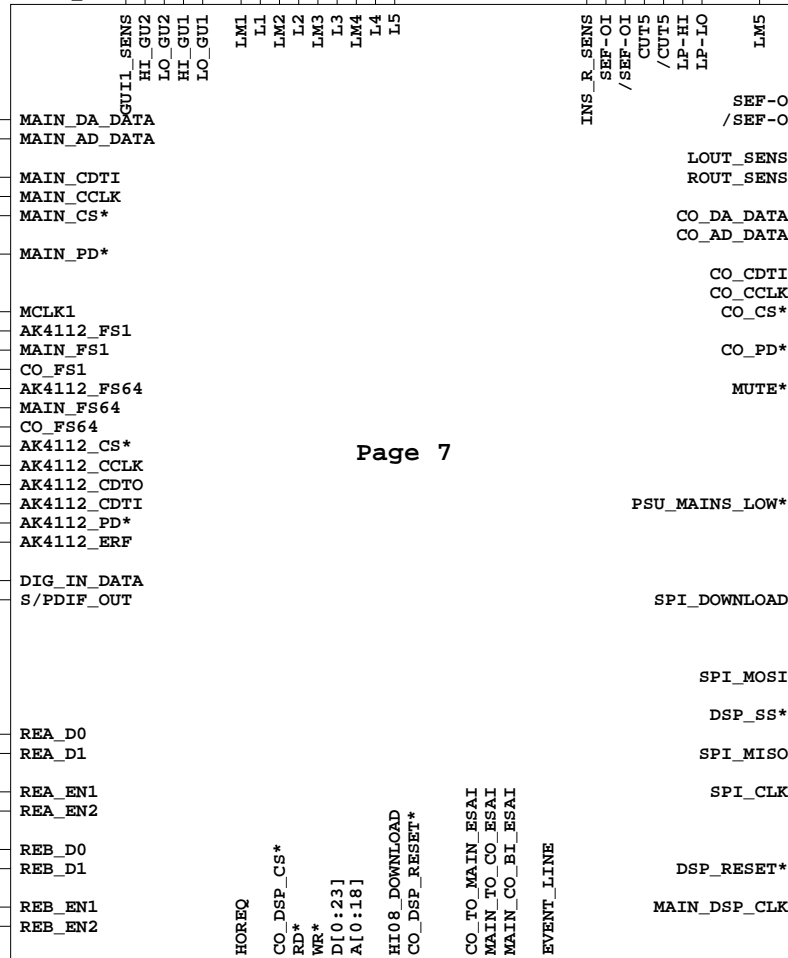

CO\_DSP

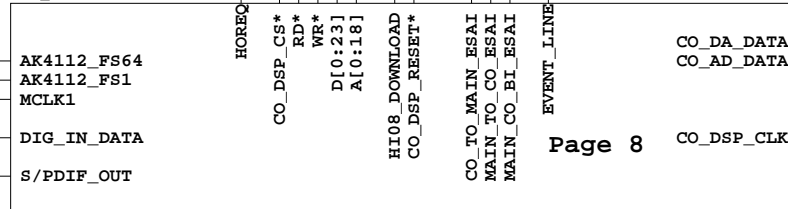

UP

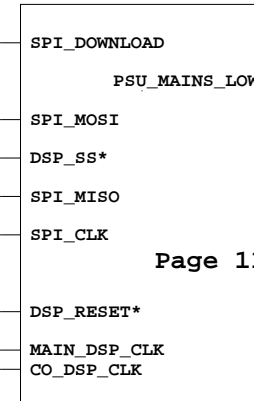

POWER

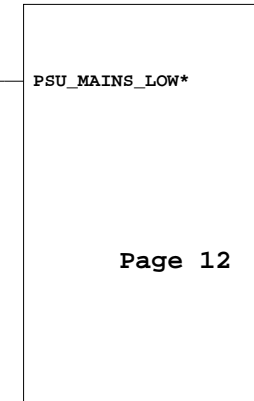

M1  
P22101-D

TC Electronic A/S		Designer
Title		HJE
GFLAT		Module title
Number	Revision	Previous page
p22101_e	EAA	XX
Date	Filename	Page / of
5-19-2005_13:03	p22101_e	1 / 2

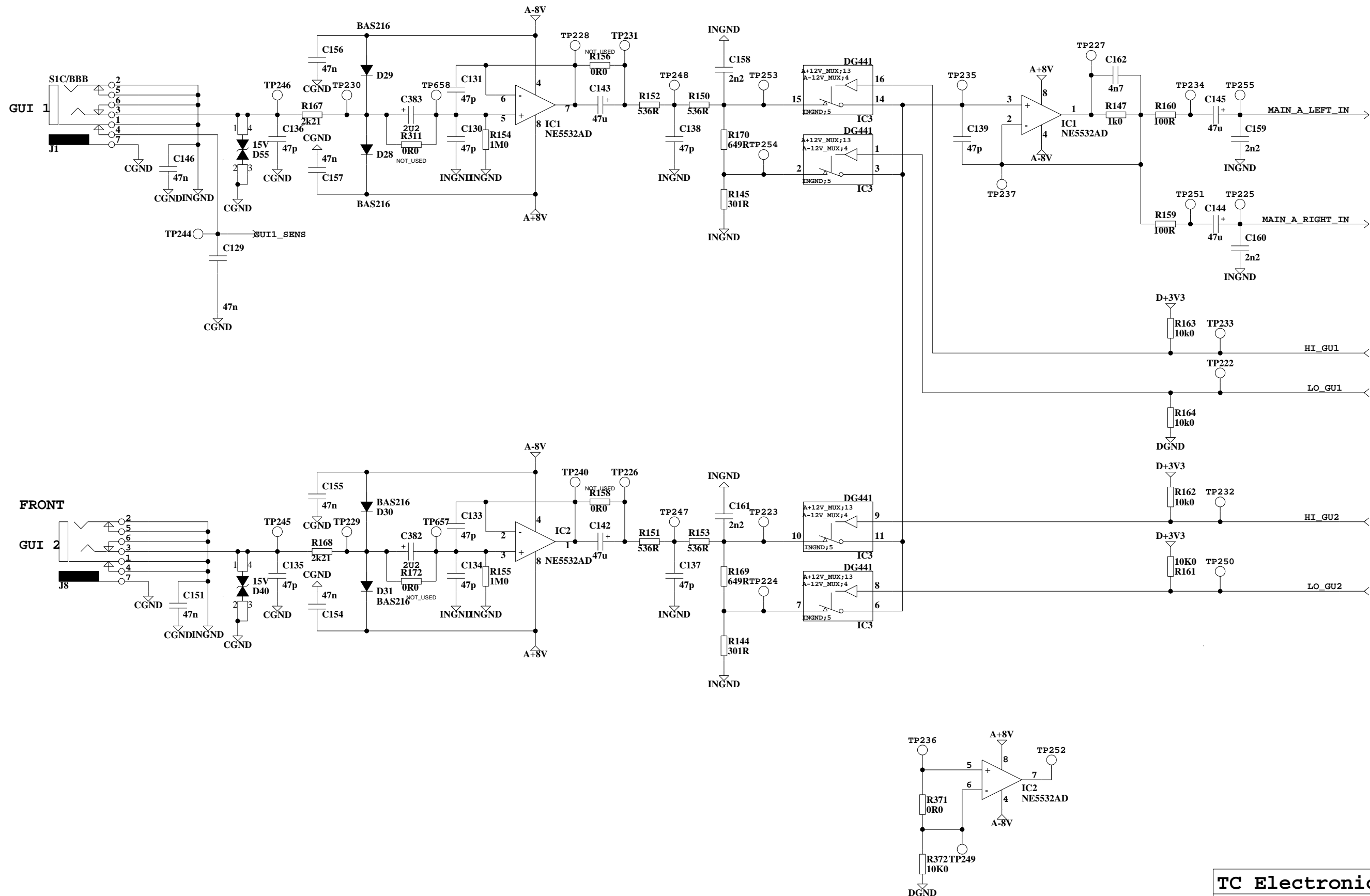

<b>TC Electronic A/S</b>		Designer HJE
Title GFLAT		Module title MAINBOARD
Number p22101_e	Revision EAA	Previous page XX
Date 5-19-2005_13:04	Filename GUITAR_INPUT	Page / of 2 / 12

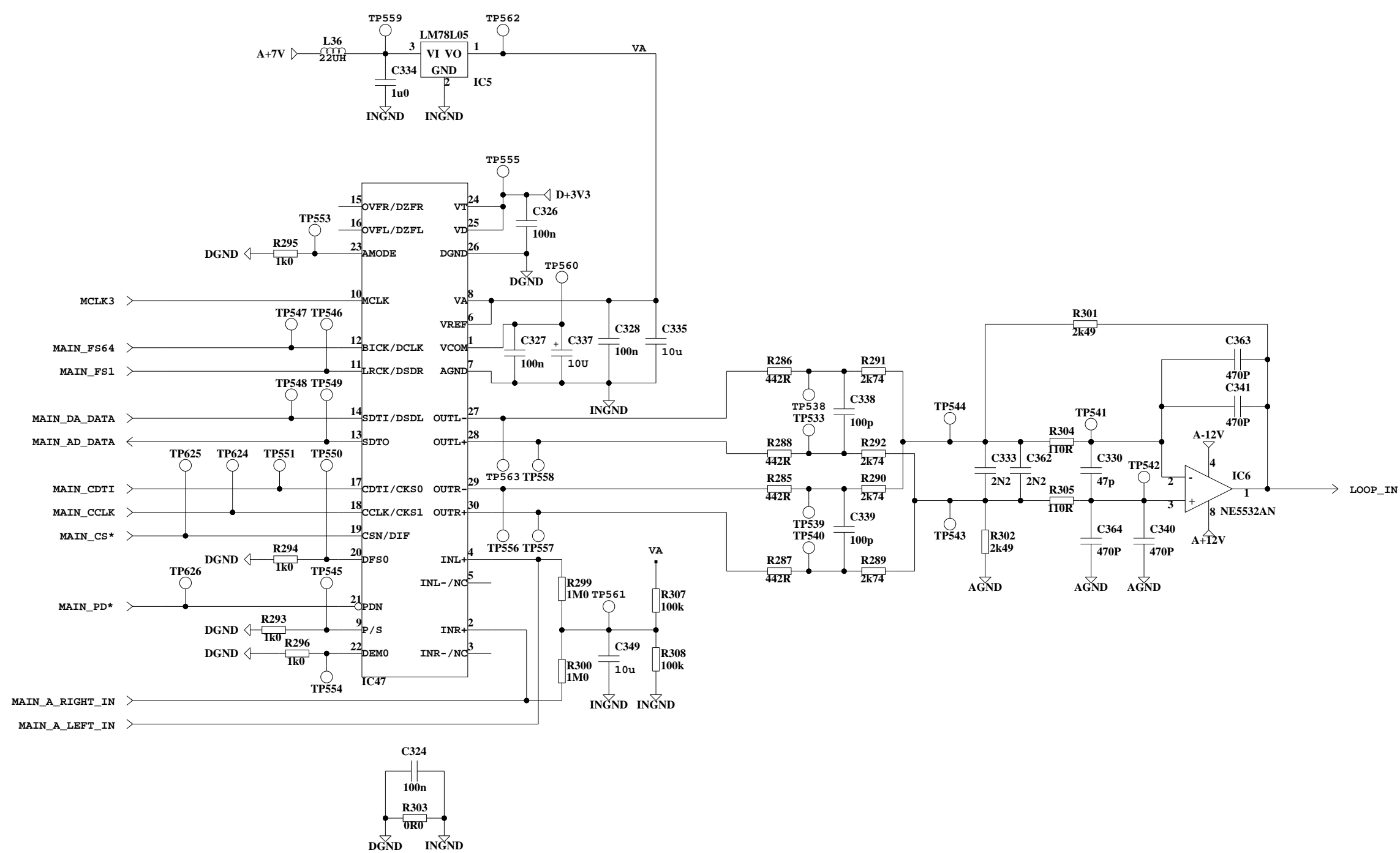

<b>TC Electronic A/S</b>		Designer HJE
Title GFLAT		Module title MAINBOARD
Number p22101_e	Revision EAA	Previous page XX
Date 5-19-2005_13:04	Filename MAIN_CODEC	Page / of 3 / 2

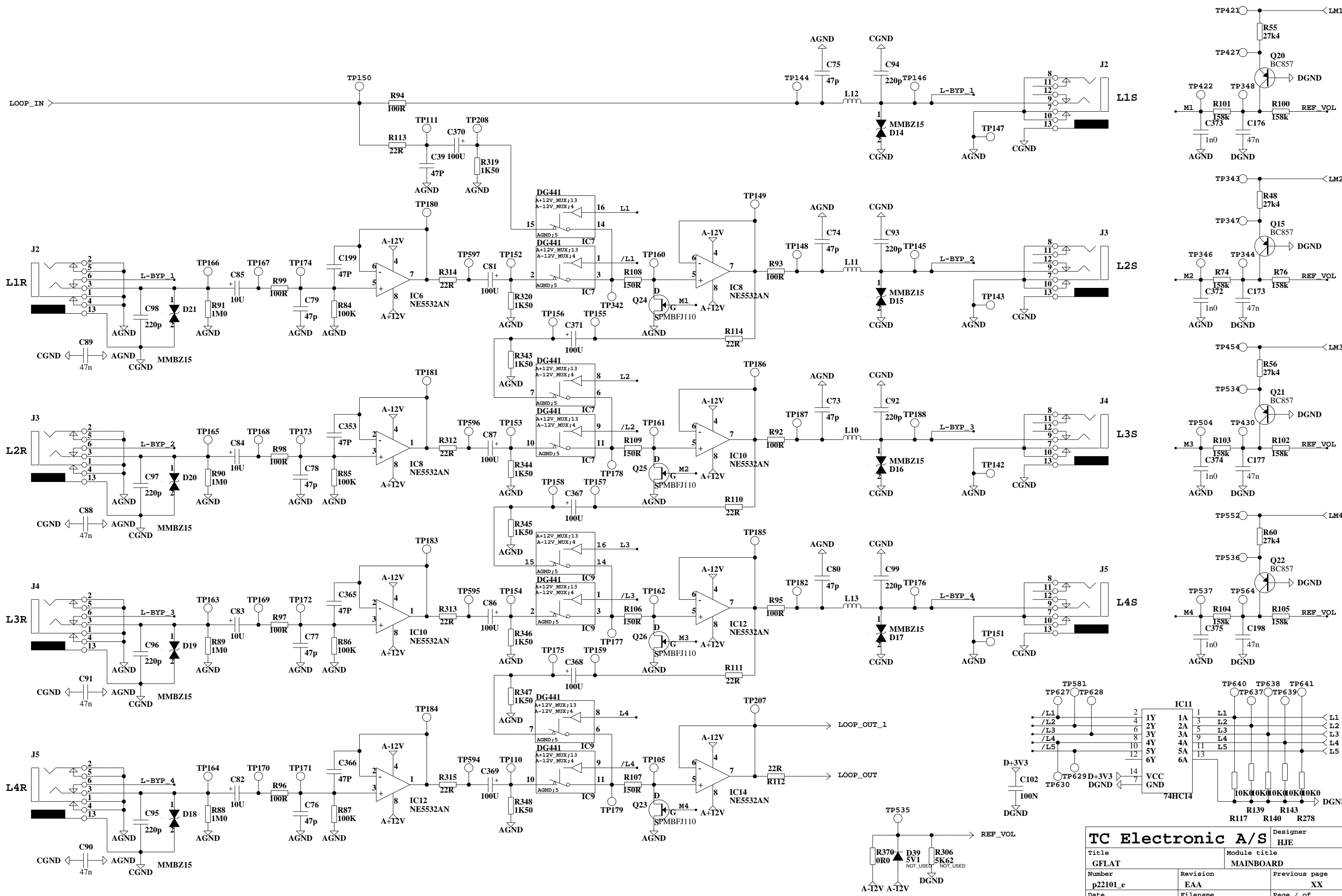

<b>TC Electronic A/S</b>		Designer HJE
Title GFLAT	Module title MAINBOARD	
Number p22101_e	Revision EAA	Previous page XX
Date 5-19-2005_13:03	Filename LOOPS	Page / of 4 / 12

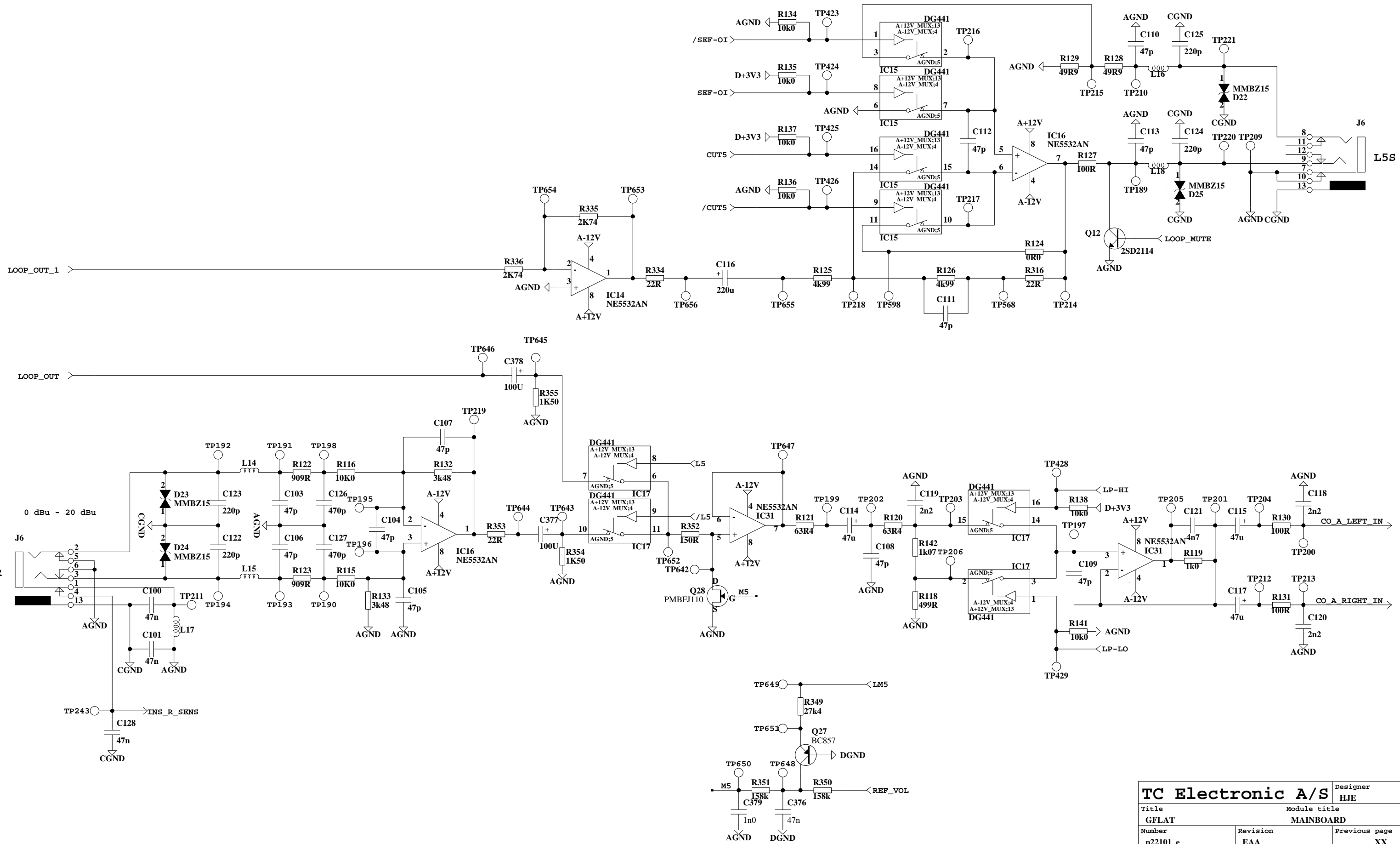

<b>TC Electronic A/S</b>		Designer HJE
Title GFLAT	Module title MAINBOARD	
Number p22101_e	Revision EAA	Previous page XX
Date 5-19-2005_13:03	Filename INSERT	Page / of 5 / 12

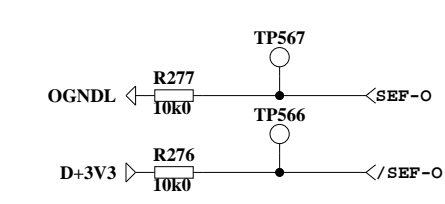
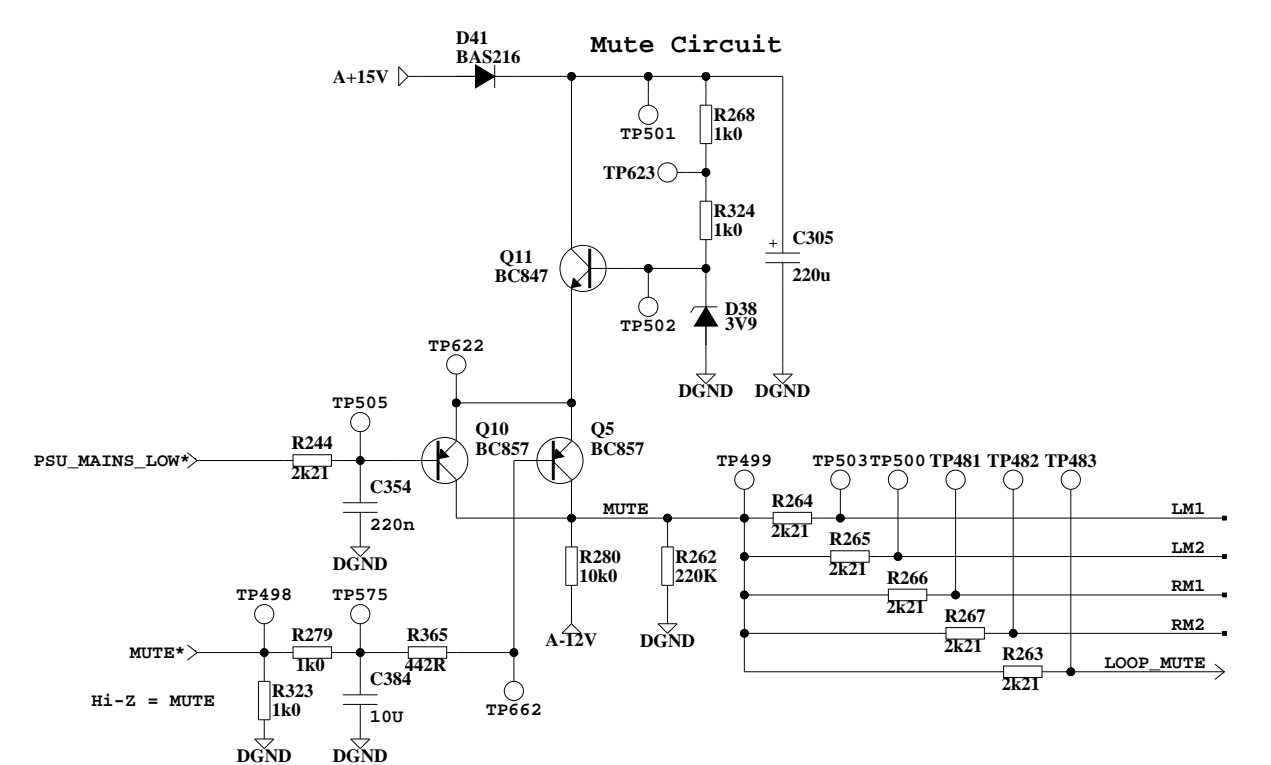
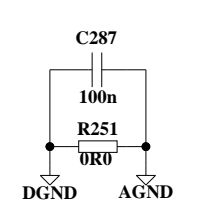
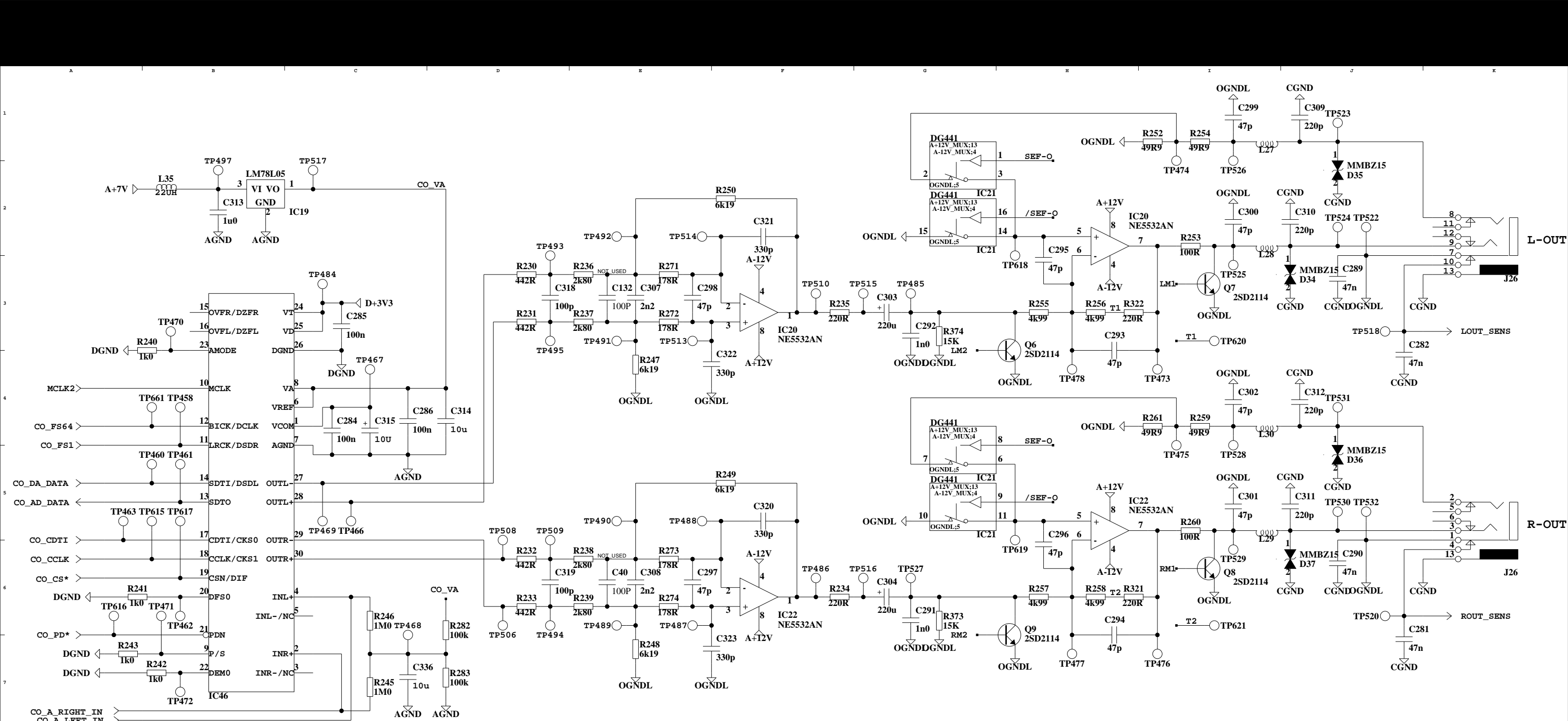

<b>TC Electronic A/S</b>		Designer HJE
Title GFLAT		Module title MAINBOARD
Number p22101_e	Revision EAA	Previous page XX
Date 5-19-2005_13:04	Filename CO_CODEC	Page / of 6 / 12

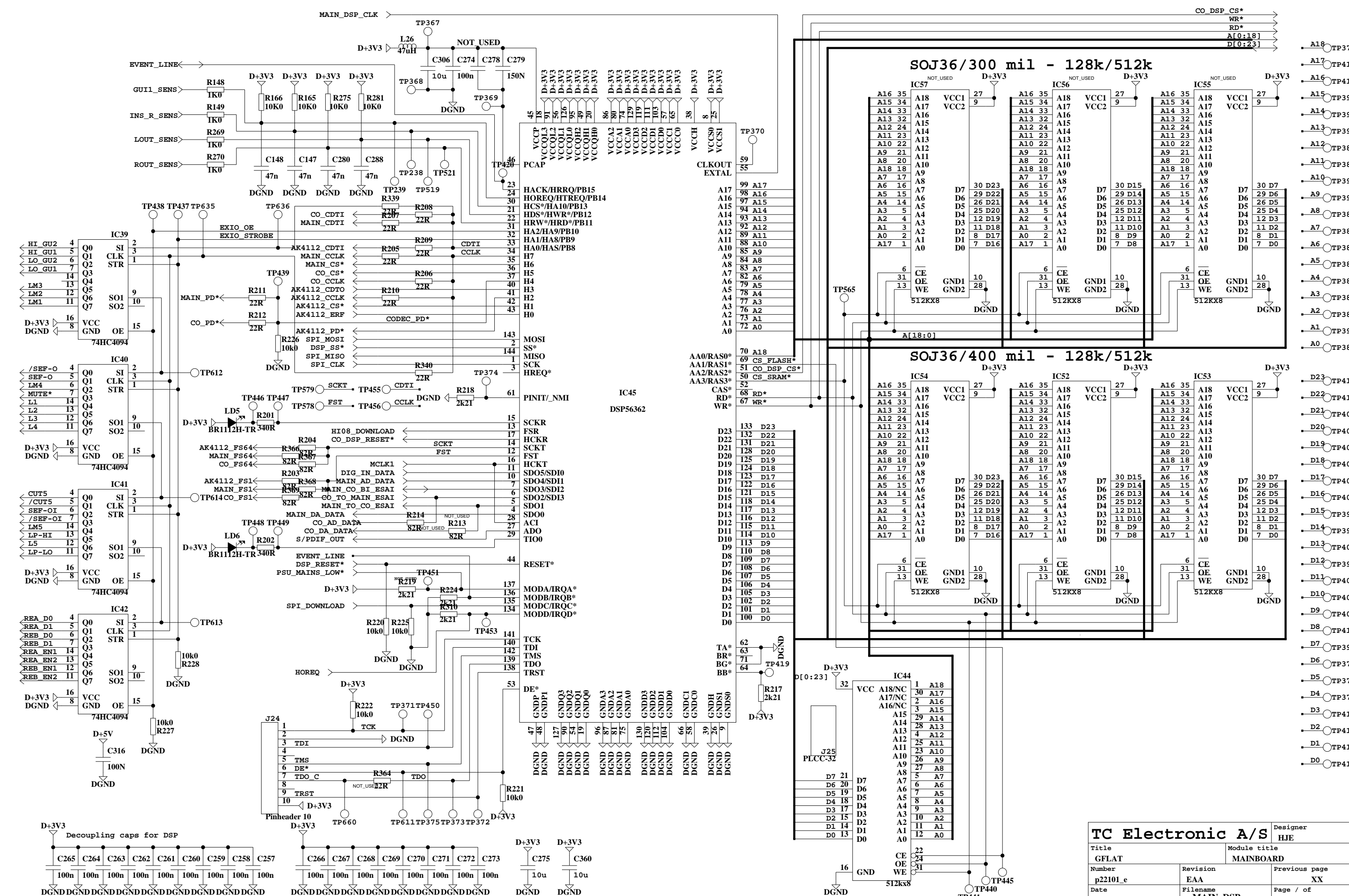

<b>TC Electronic A/S</b>		Designer HJE
Title GFLAT		Module title MAINBOARD
Number p22101_e	Revision EAA	Previous page XX
Date 5-19-2005 13:25	Filename MAIN_DSP	Page / of 7 / 12

TP317 A1 18  
 TP299 A1 17  
 TP300 A1 16  
 TP301 A1 15  
 TP302 A1 14  
 TP303 A1 13  
 TP304 A1 12  
 TP305 A1 11  
 TP306 A1 10  
 TP307 A1 9  
 TP308 A1 8  
 TP309 A1 7  
 TP310 A1 6  
 TP311 A1 5  
 TP312 A1 4  
 TP313 A1 3  
 TP314 A1 2  
 TP315 A1 1  
 TP316 A1 0  
 TP318 D1 23  
 TP319 D1 22  
 TP320 D1 21  
 TP321 D1 20  
 TP322 D1 19  
 TP323 D1 18  
 TP324 D1 17  
 TP325 D1 16  
 TP326 D1 15  
 TP327 D1 14  
 TP328 D1 13  
 TP329 D1 12  
 TP330 D1 11  
 TP331 D1 10  
 TP332 D1 9  
 TP333 D1 8  
 TP335 D1 6  
 TP334 D1 7  
 TP336 D1 5  
 TP337 D1 4  
 TP338 D1 3  
 TP339 D1 2  
 TP340 D1 1  
 TP341 D1 0

SOJ36/300 mil - 128k/512k

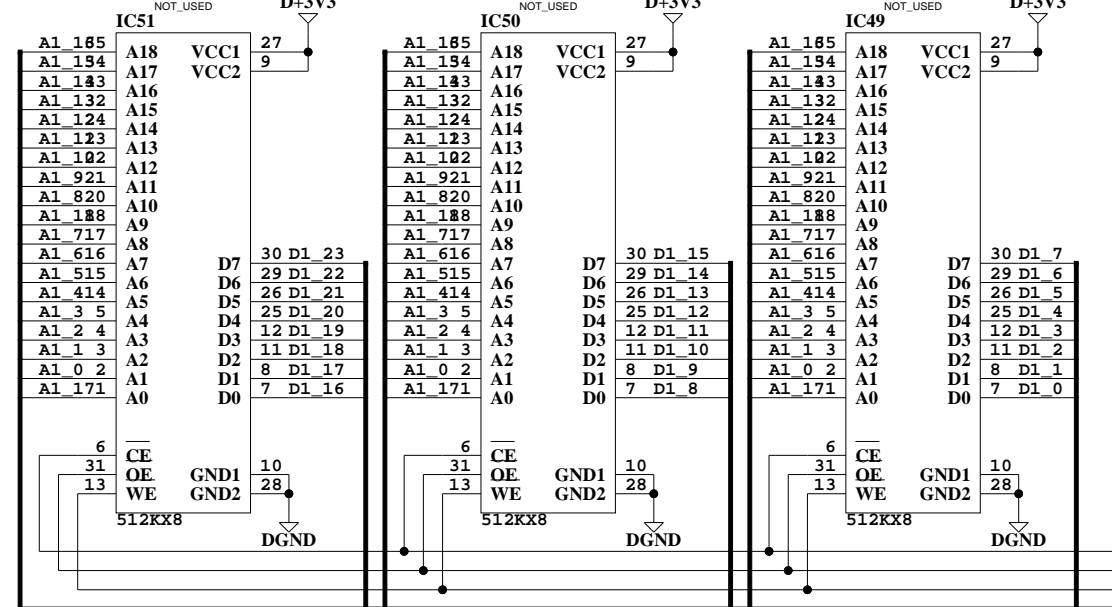

SOJ36/400 mil - 128k/512k

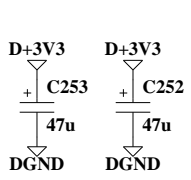
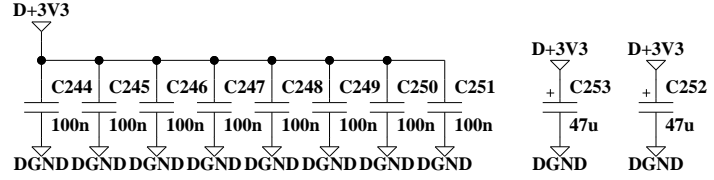
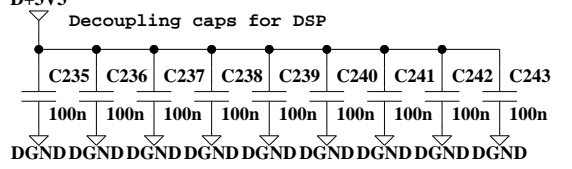
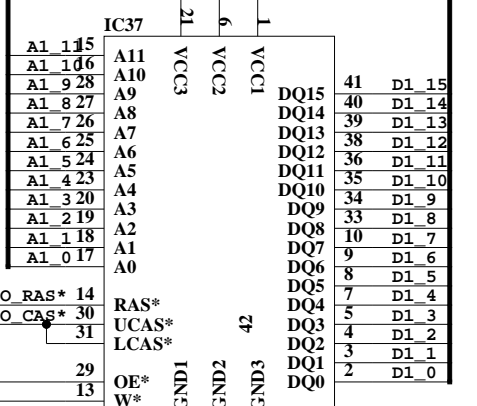
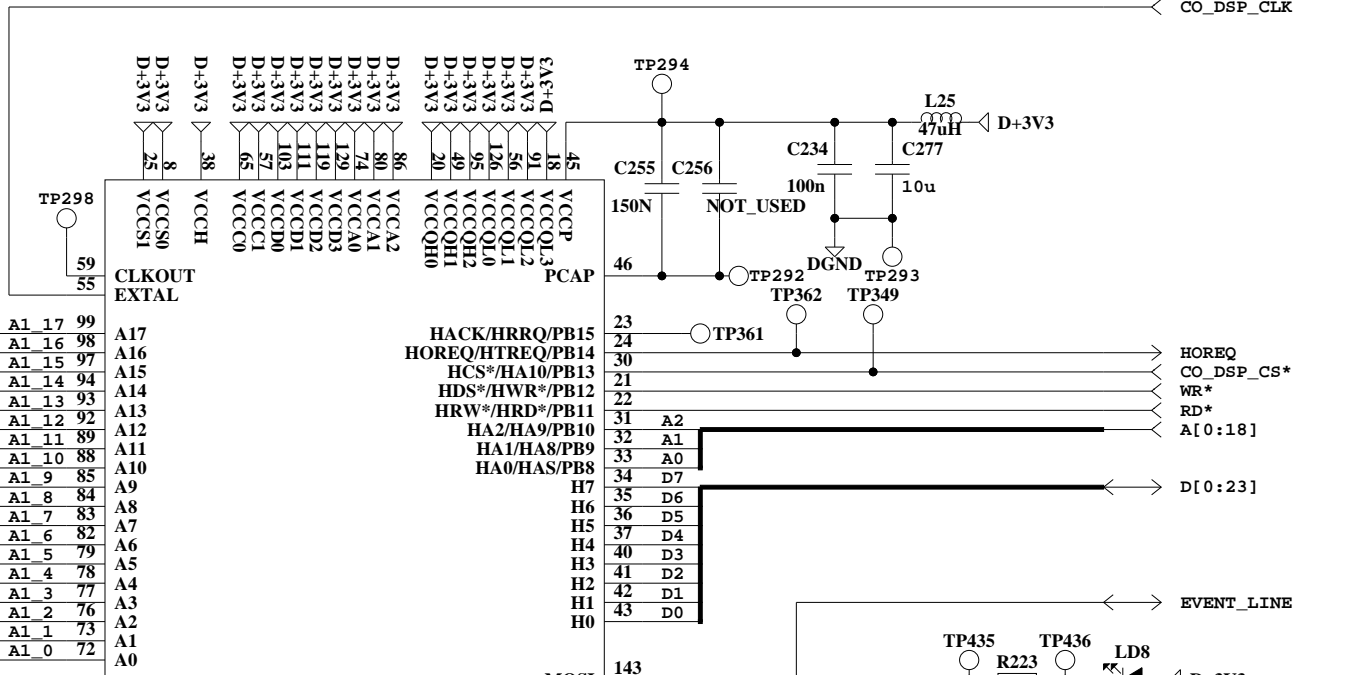
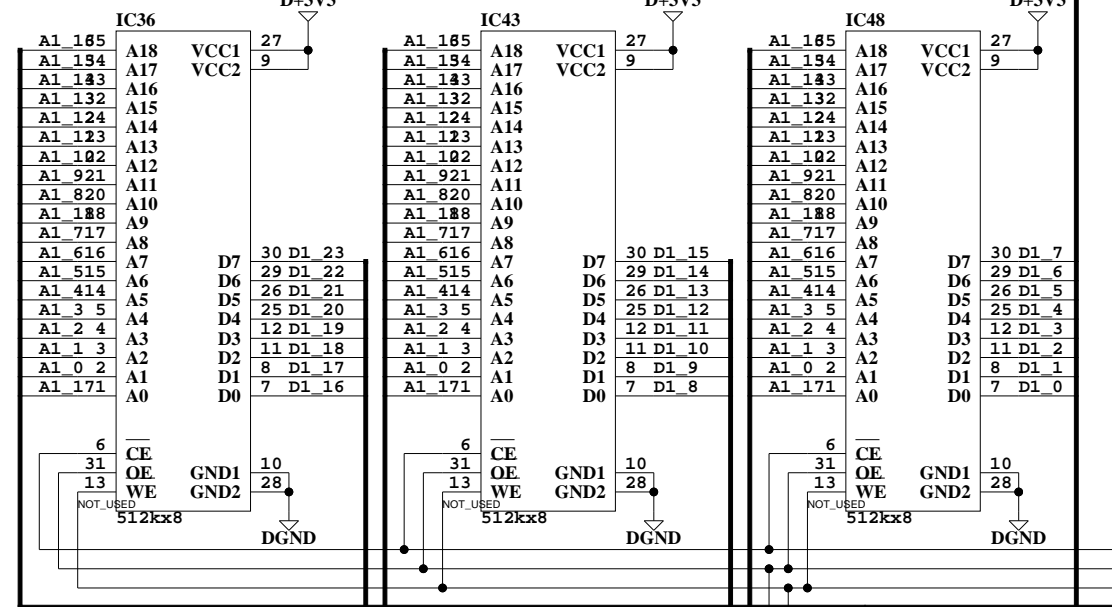

TC Electronic A/S Designer HJE

Title GFLAT		Module title MAINBOARD	
Number p22101_e	Revision EAA	Previous page XX	
Date 5-19-2005_13:04	Filename CO_DSP	Page / of 8 / 12	



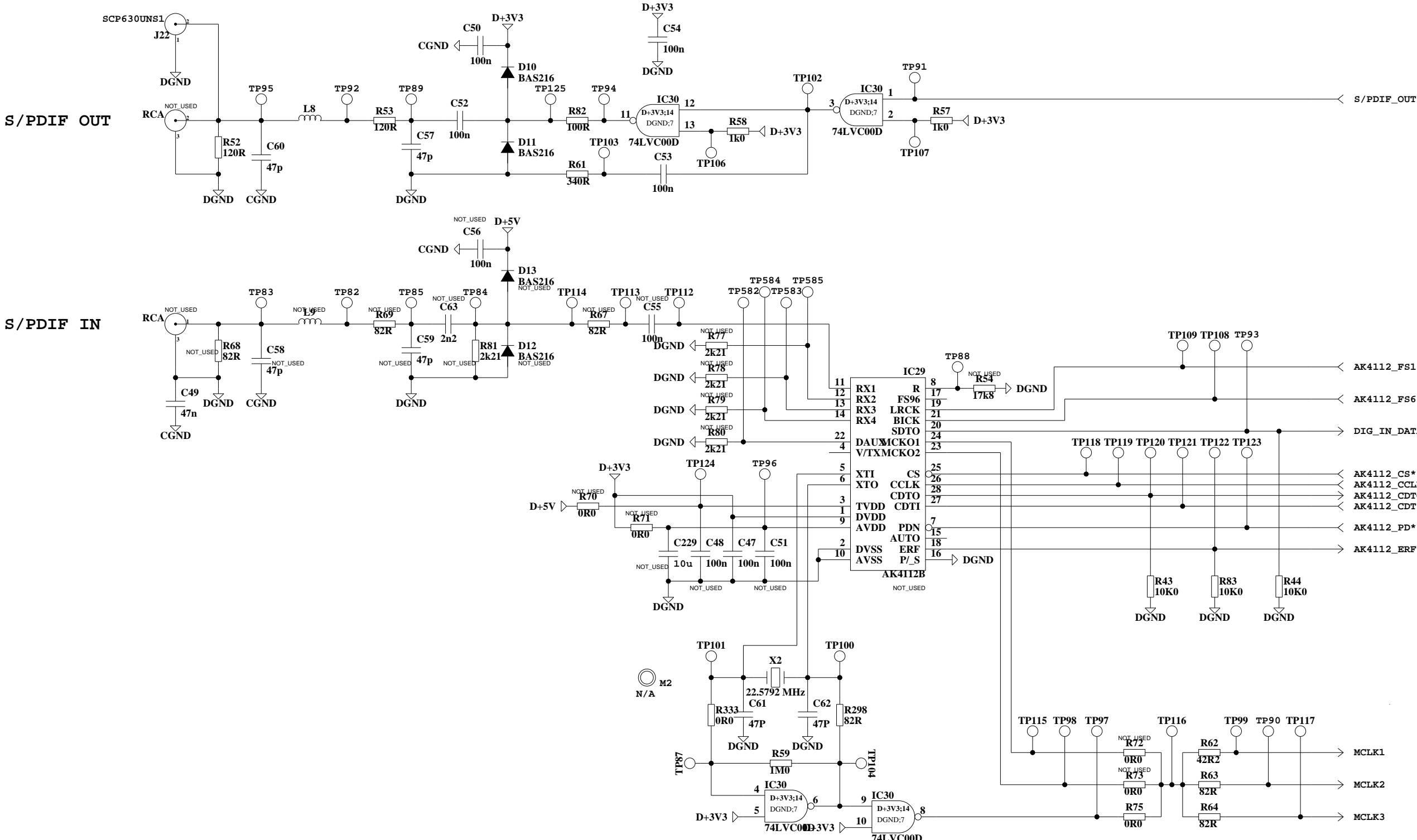

<b>TC Electronic A/S</b>		Designer HJE
Title GFLAT		Module title MAINBOARD
Number p22101_e	Revision EAA	Previous page XX
Date 5-19-2005_13:03	Filename DIGITAL_IN_OUT	Page / of 9 / 12

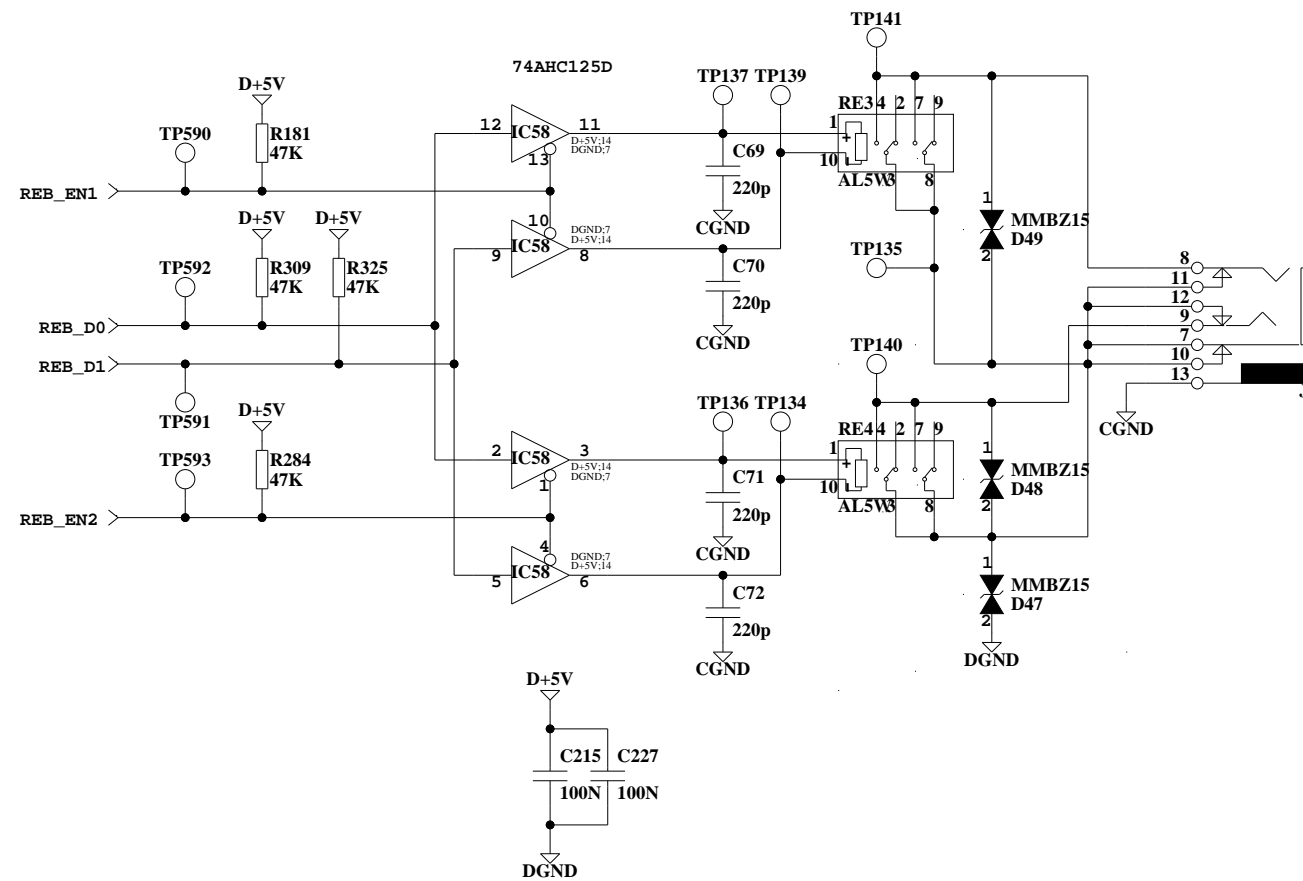
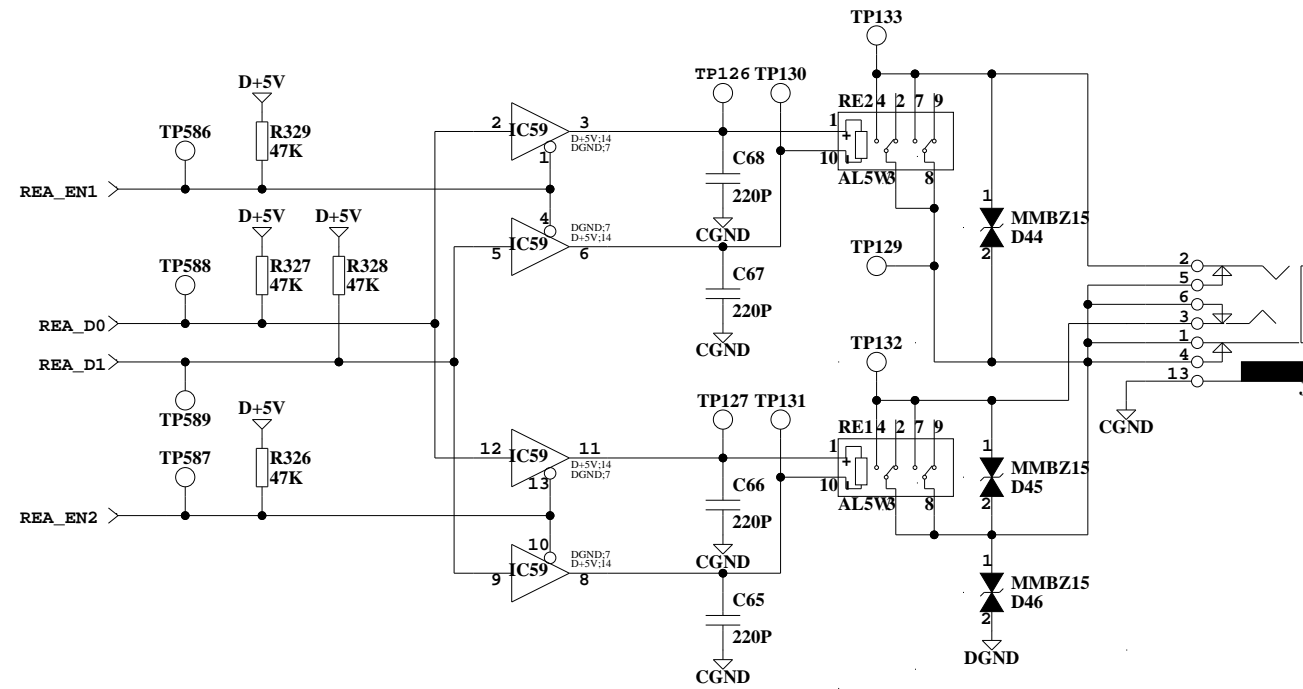

TC Electronic A/S		Designer HJE
Title GFLAT		Module title MAINBOARD
Number p22101_e	Revision EAA	Previous page XX
Date 5-19-2005_13:03	Filename SWITCHOUTPUTS	Page / of 10 / 12

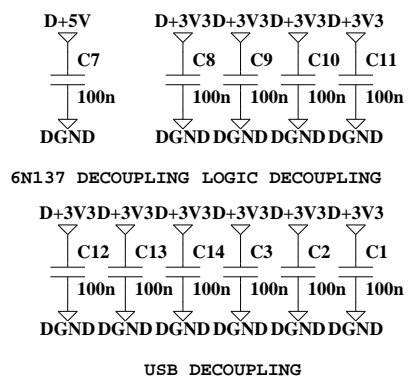
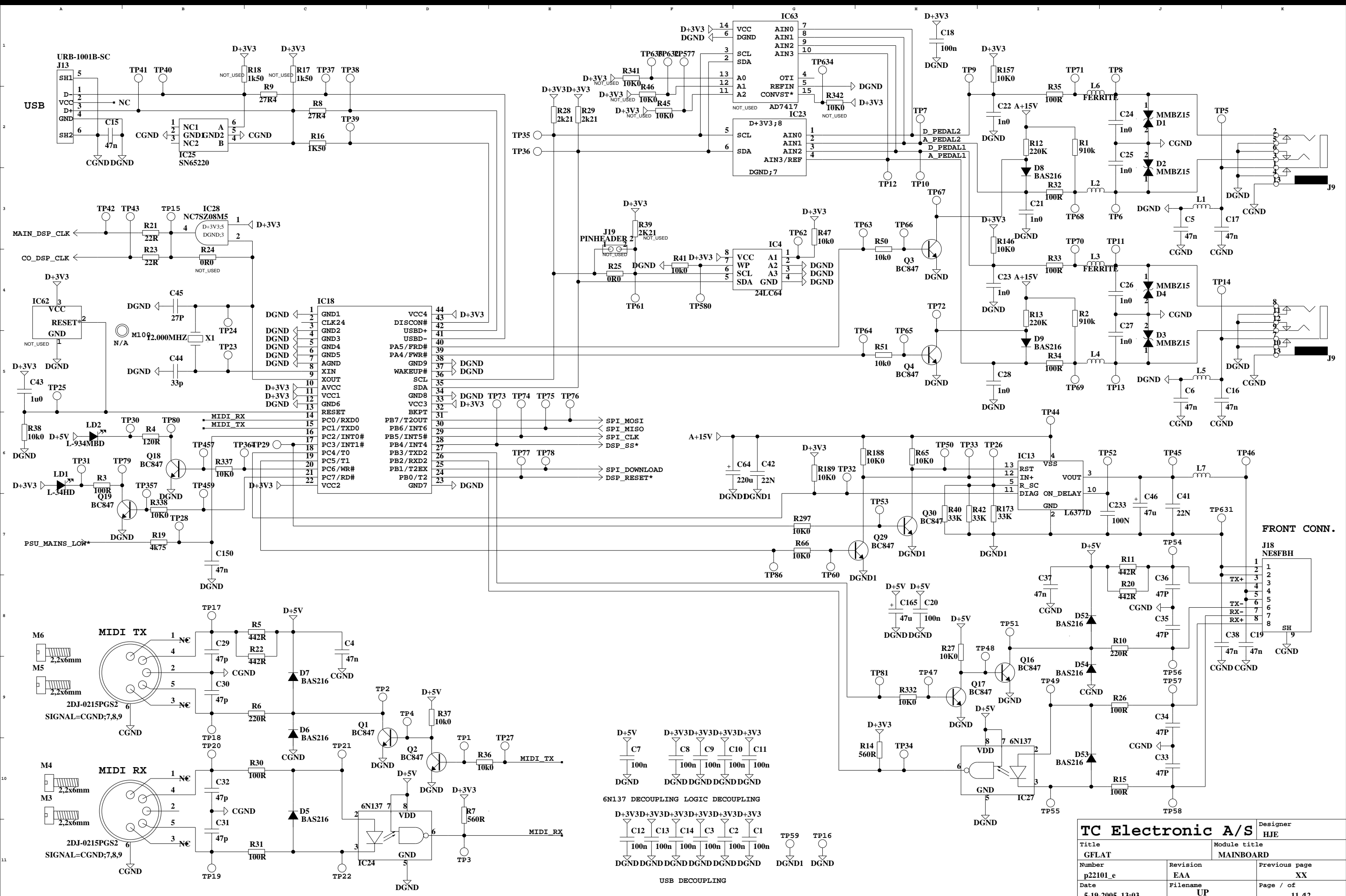

<b>TC Electronic A/S</b>		Designer HJE
Title GLFAT		Module title MAINBOARD
Number p22101_e	Revision EAA	Previous page XX
Date 5-19-2005_13:03	Filename UP	Page / of 11 / 12

**SMP5 CONNECTIONS**

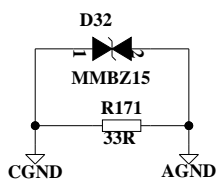
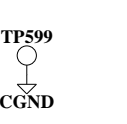
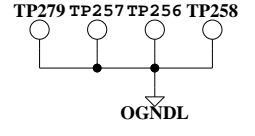
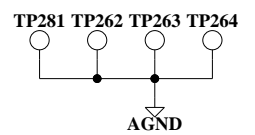
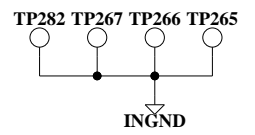
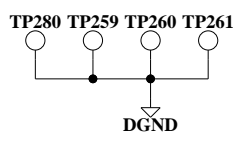
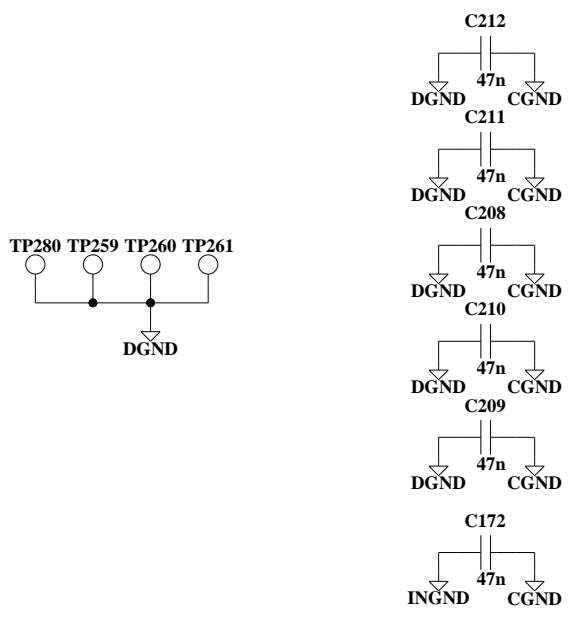
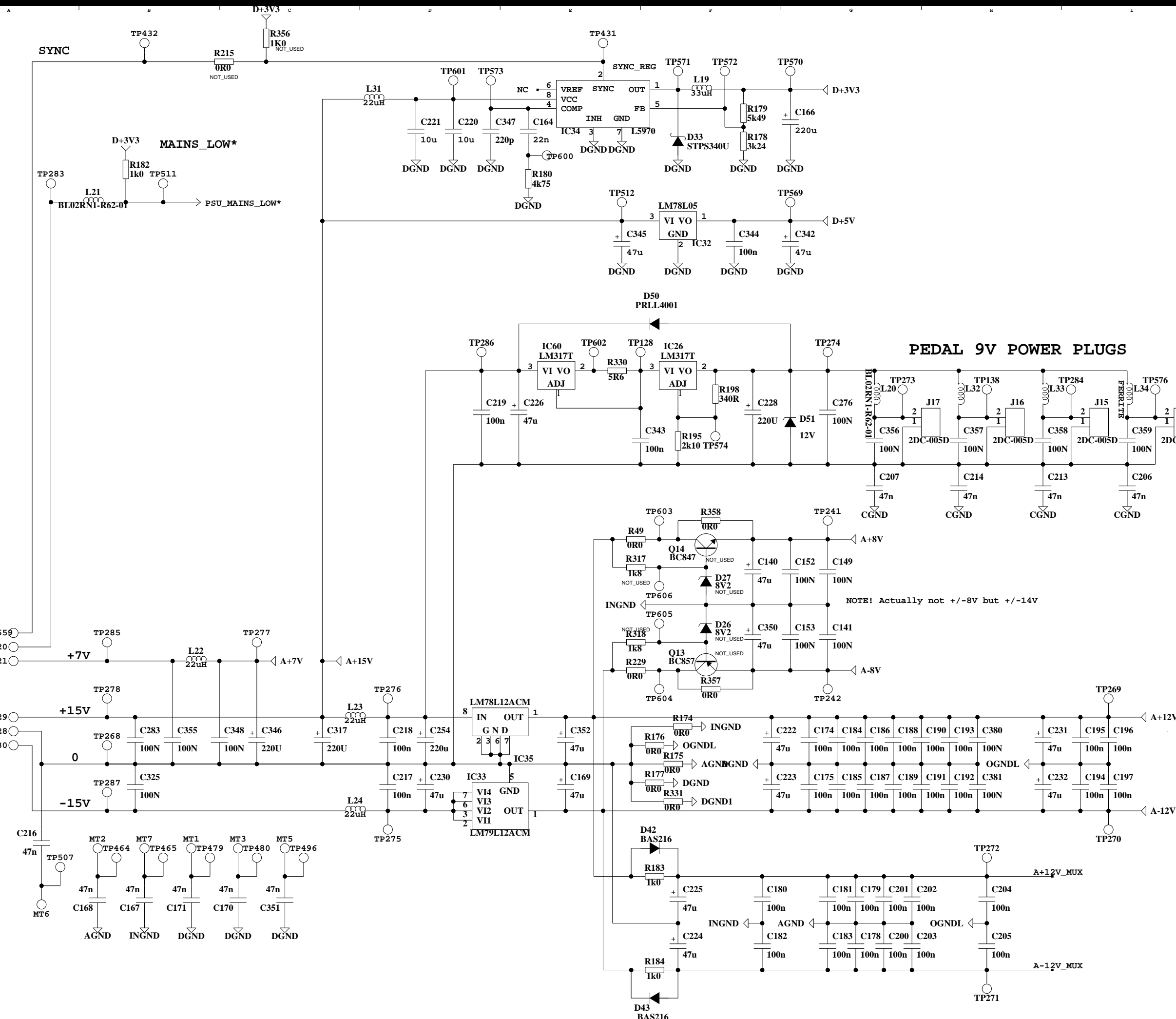

<b>TC Electronic A/S</b>		Designer HJE
Title GFLAT	Module title MAINBOARD	
Number p22101_e	Revision EAA	Previous page XX
Date 5-19-2005_13:04	Filename POWER	Page / of 12 / 12