

M1
P22593-C
pcb

				Designer(s) HJE/PRO	
Title 1217-ATOMIC (HOF MINI)				Module title MODULE TITLE	
Number P22593	Revision C	Variant A	Version A	Board type UI BOARD	
Date 12/09/2013:09:47	Filename			Page / of 1 / 4	

CON on Rear side

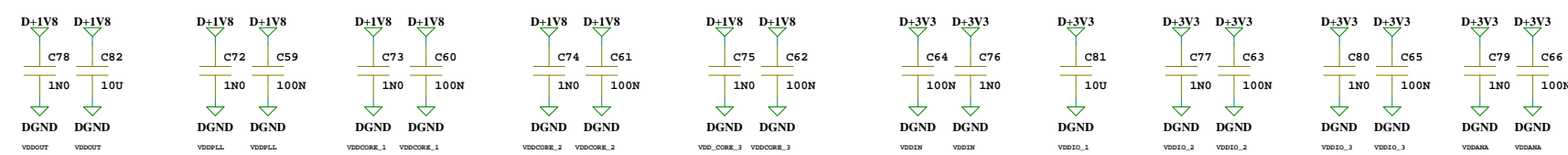
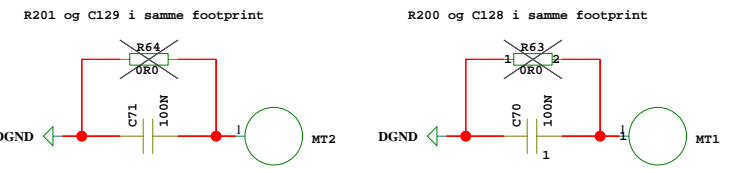
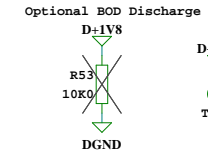
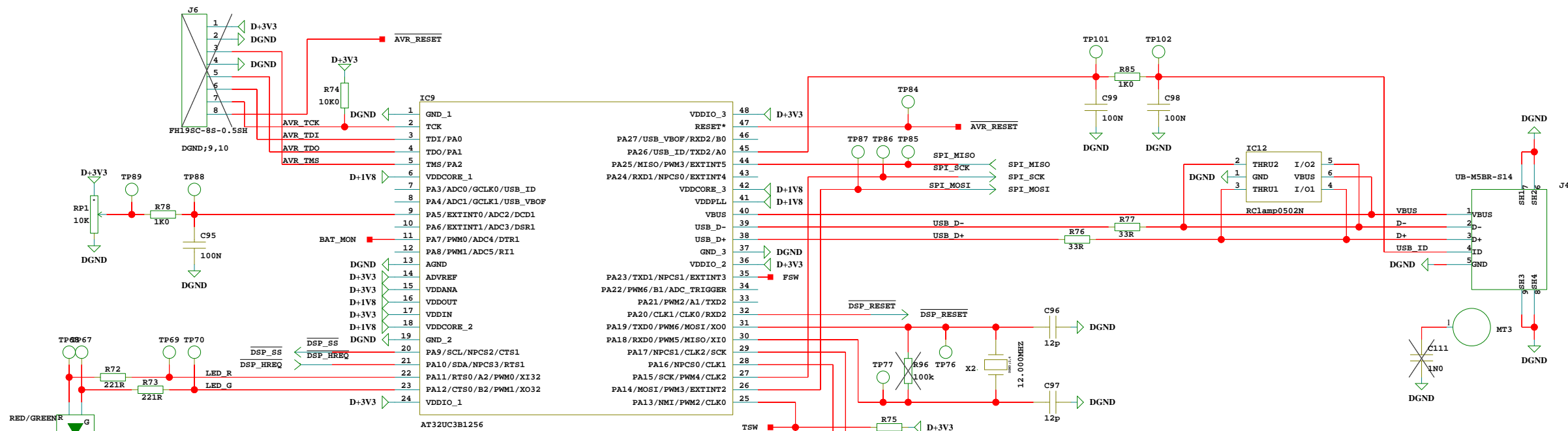
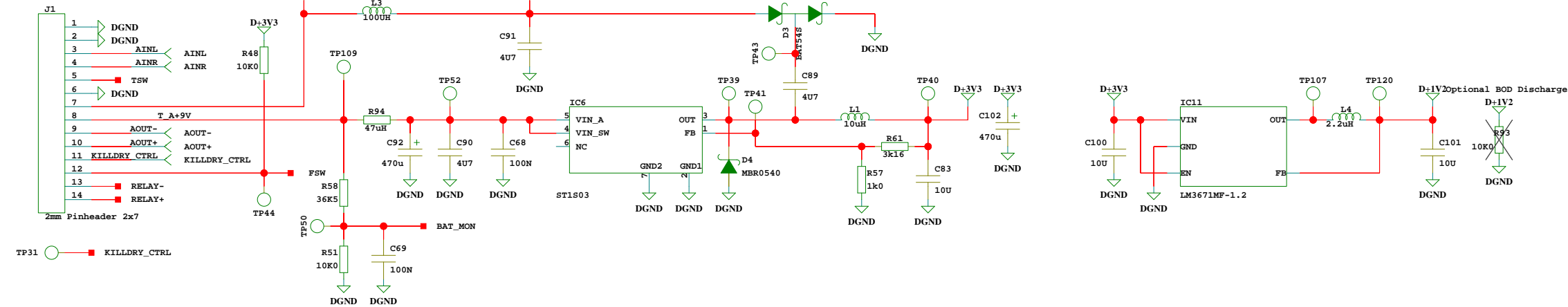

		Designer(s)	
Title 1217-ATOMIC (HOF MINI)		HJE/PRO	
Number P22593		Module title MODULE TITLE	
Date 12/09/2013:09:48		Board type UI BOARD	
Revision C	Variant A	Version A	Page / of 2 / 4
Filename uc_and_connects		Page / of 2 / 4	

15pF/18pF?

