

EIO3 (Impact Mobile)

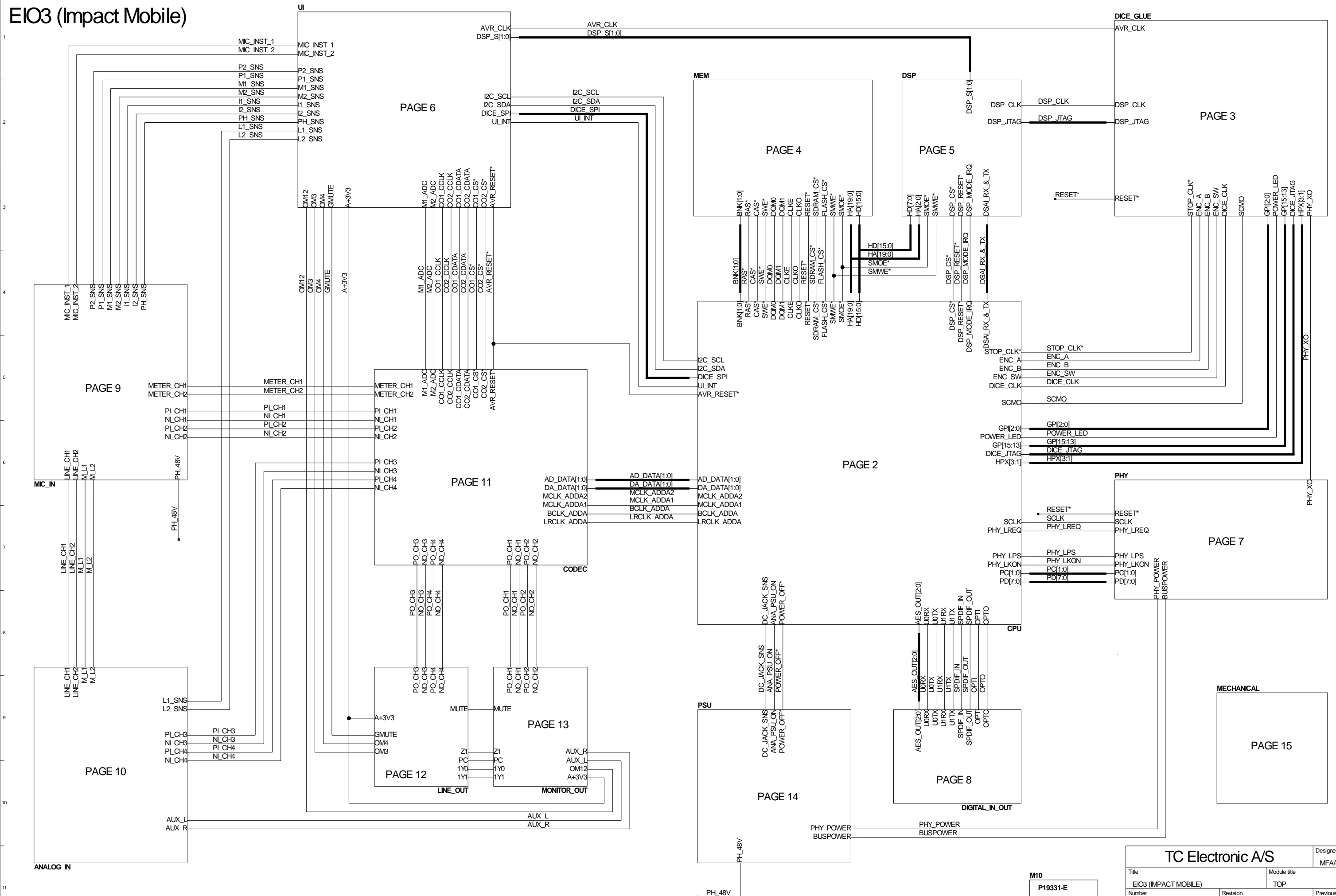

TC Electronic A/S		Designer
Title		MFA/LHO
EIO3 (IMPACT MOBILE)		Module title
TOP		
Number	Revision	Previous page
P19331	EDB	NONE
Date	Filename	Page / of
7-1-2009_15:15	P19331-ED	1 / 15

M10
P19331-E

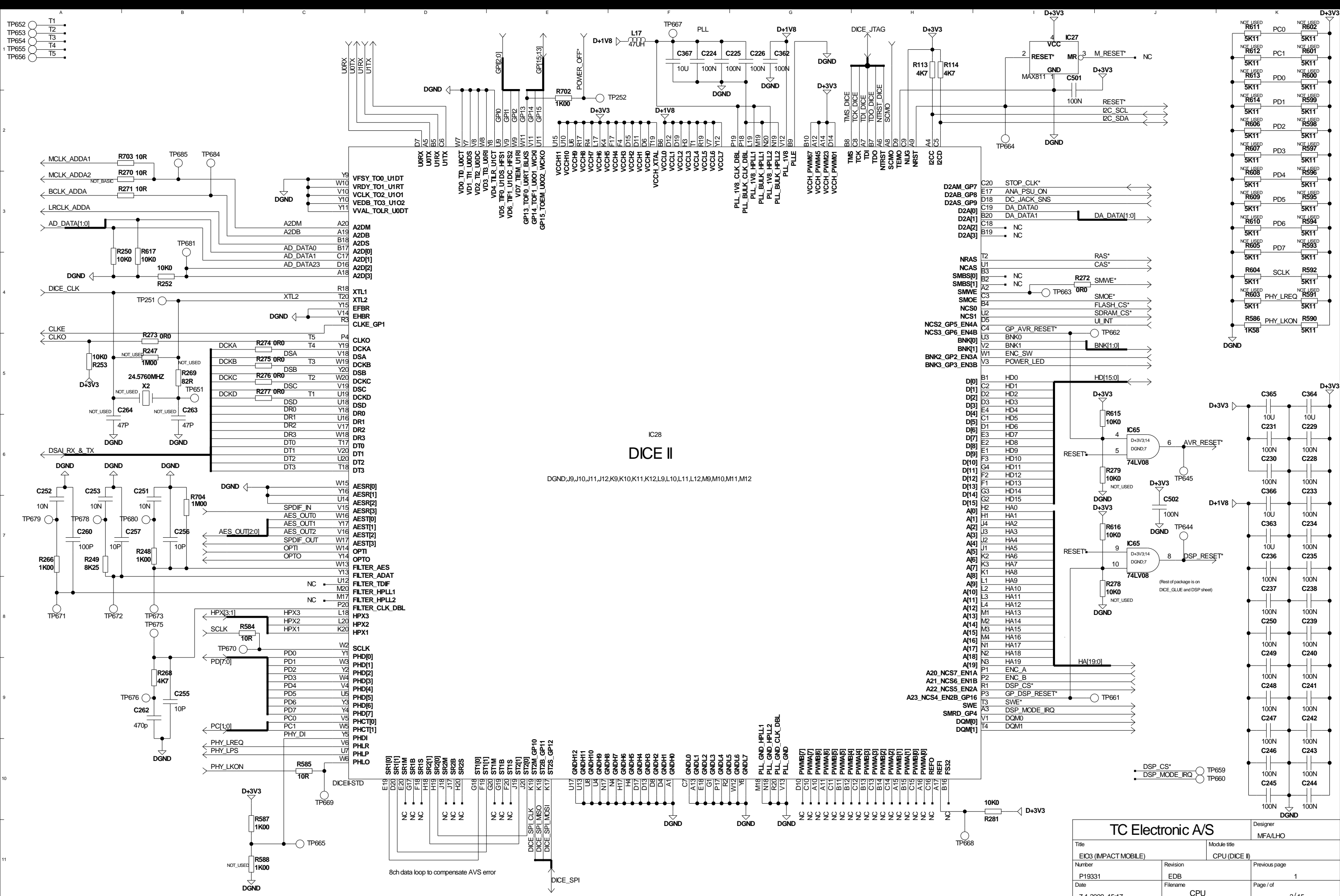

IC28
DICE II
DGND;J9,J10,J11,J12,K9,K10,K11,K12,L9,L10,L11,L12,M9,M10,M11,M12

8ch data loop to compensate AVS error

TC Electronic A/S		Designer	MFA/LHO
Title		Module title	
EIO3 (IMPACT MOBILE)		CPU (DICE II)	
Number	Revision	Previous page	
P19331	EDB	1	
Date	Filename	Page / of	
7-1-2009_15:17	CPU	2 / 15	

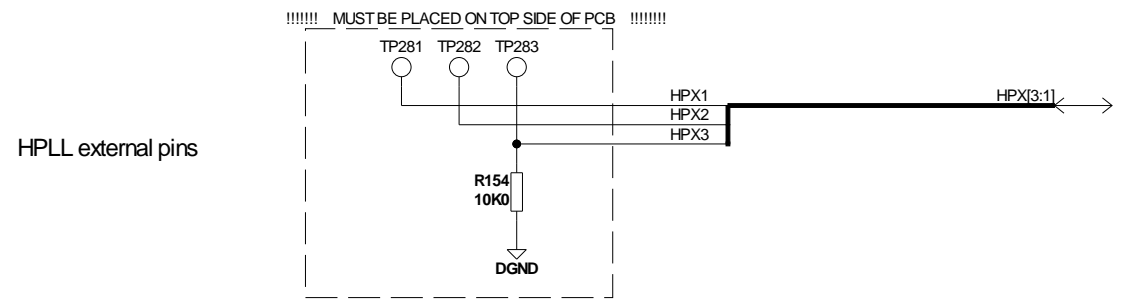
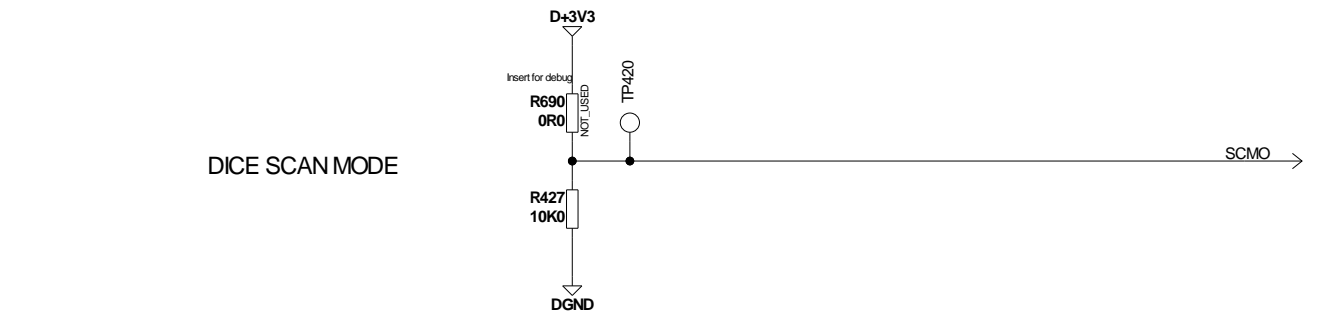
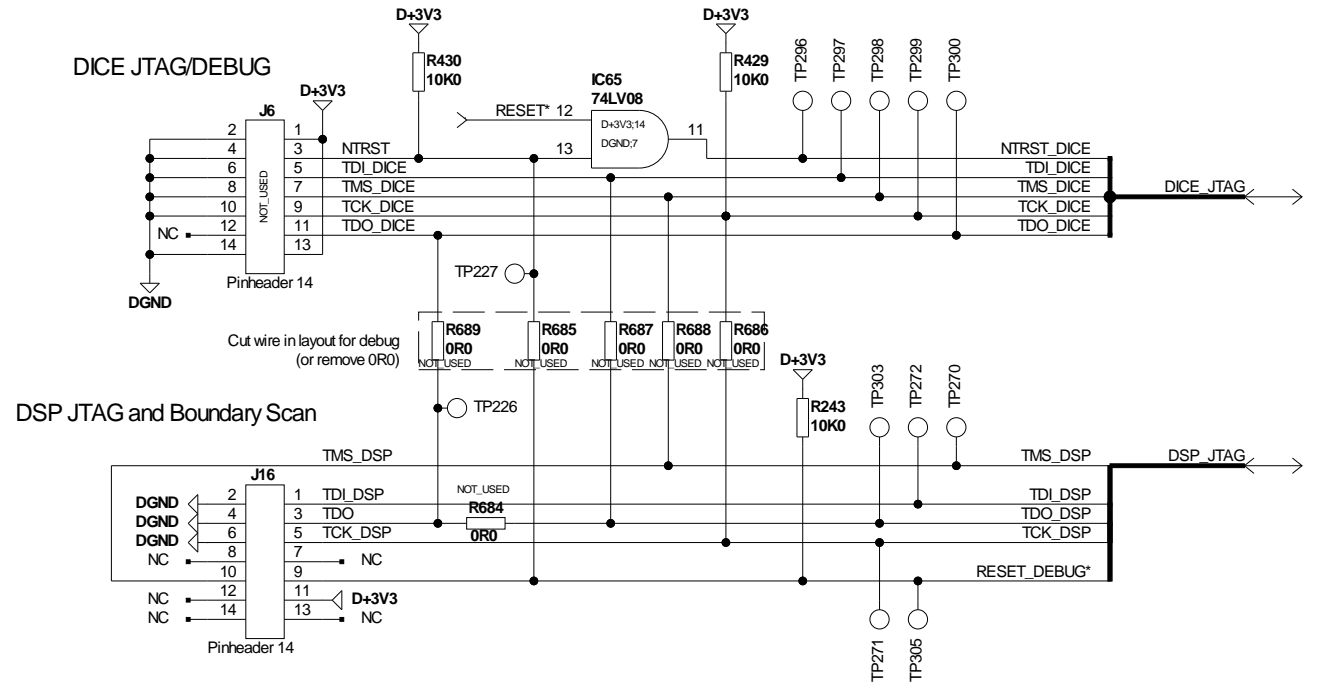
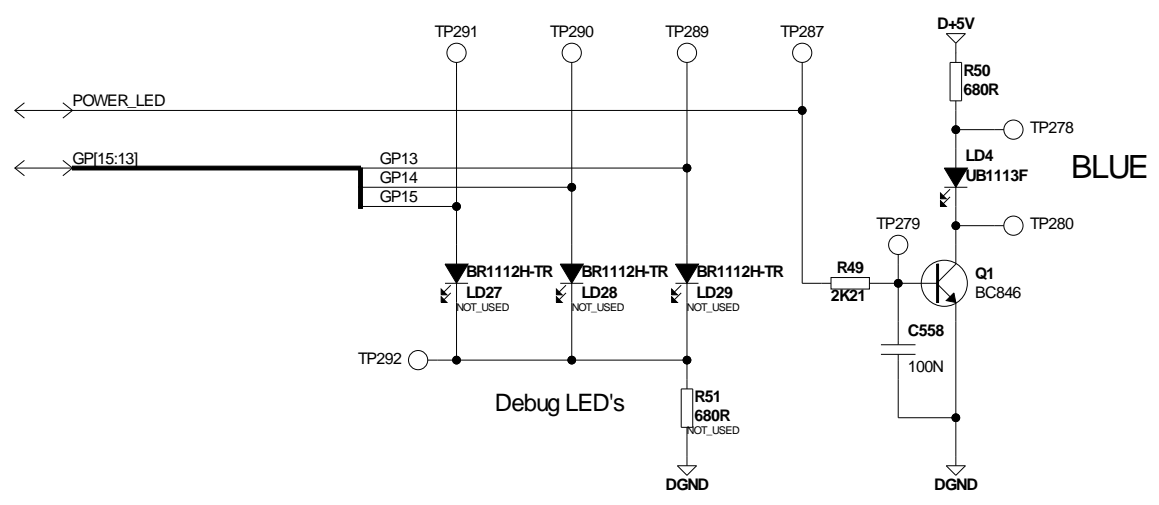
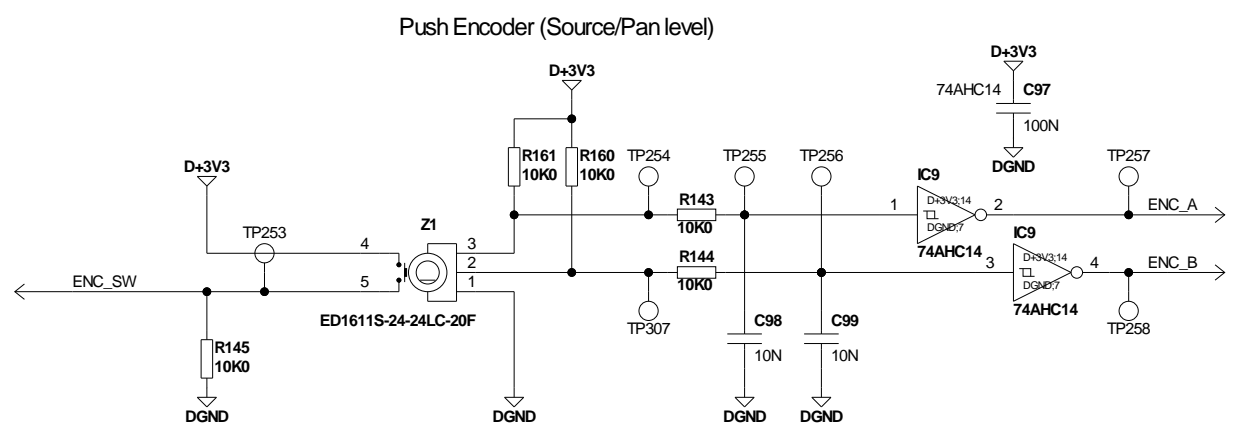
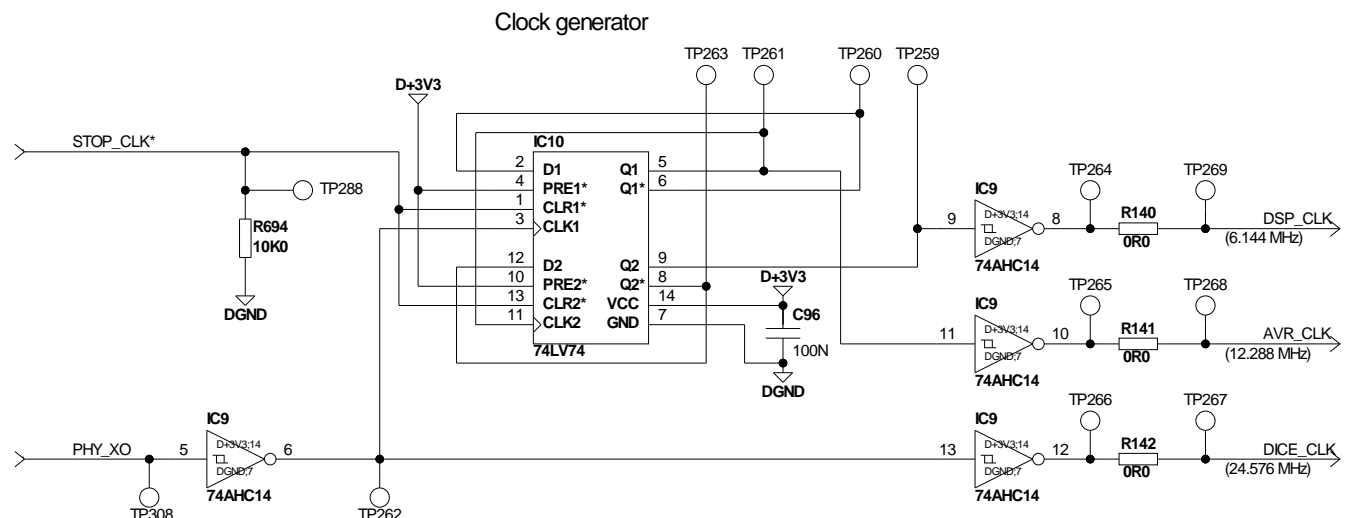

Variant Control

	GP0	GP1	GP2
Konnekt 24D	= 0	0	0
Konnekt 8	= 0	0	1
Konnekt Live	= 0	1	0
Impact Mobile	= 0	1	1

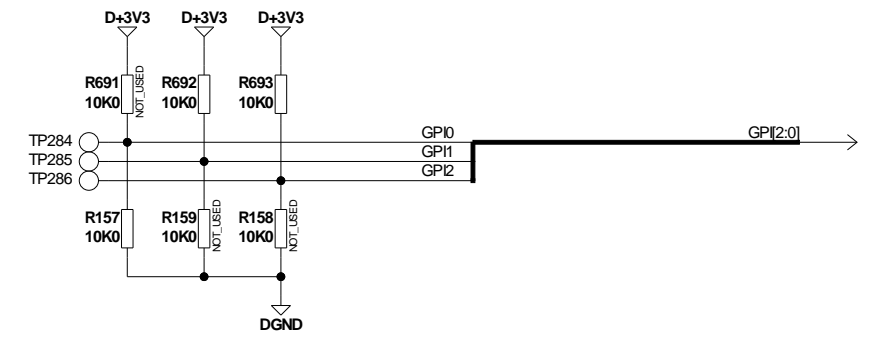

TC Electronic A/S		Designer MFA
Title EIO3 (IMPACT MOBILE)		Module title DICE_GLUE
Number P19331	Revision EDB	Previous page 1
Date 7-1-2009_15:16	Filename DICE_GLUE	Page / of 3 / 15

Host Memory

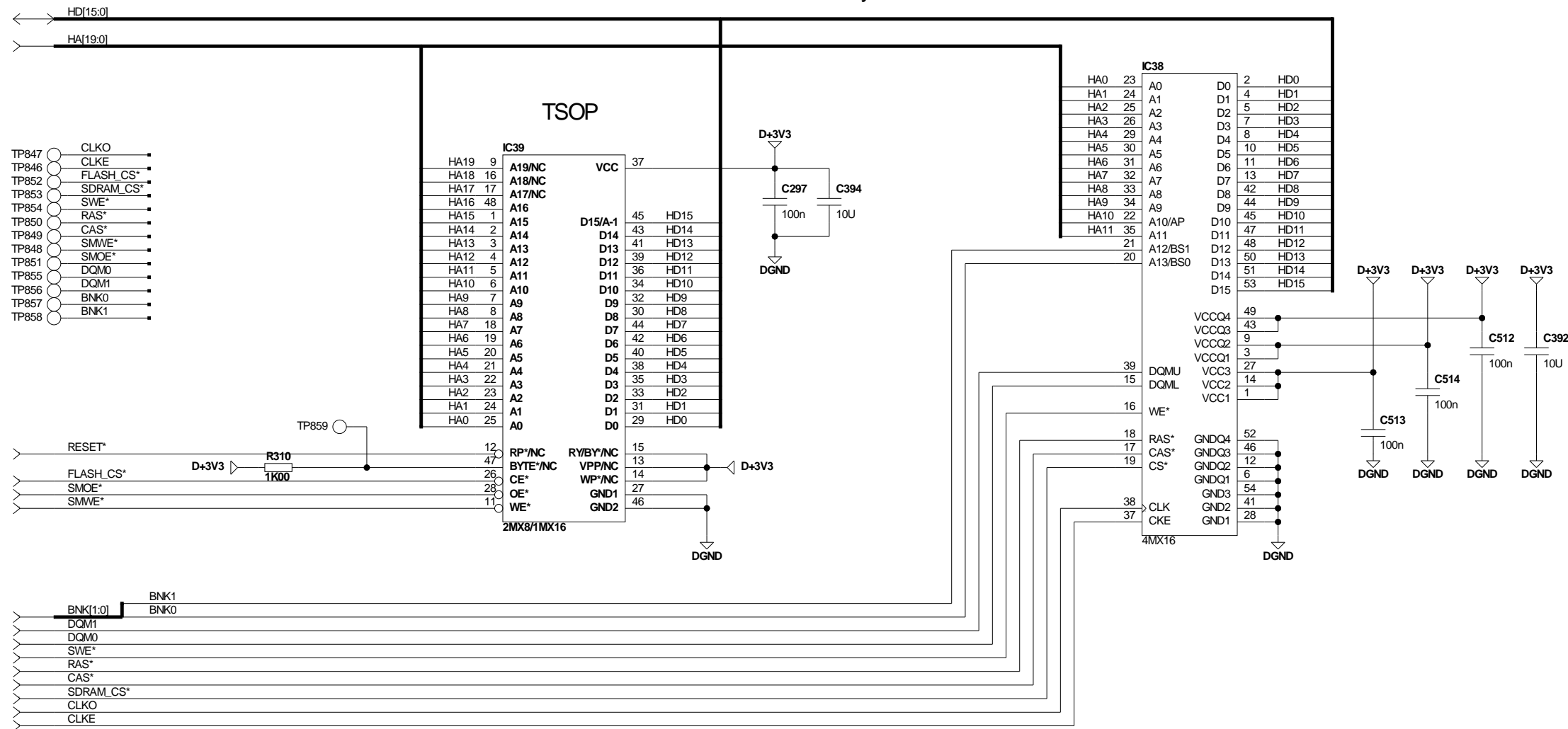

- TP835 HD0
- TP834 HD1
- TP836 HD2
- TP842 HD3
- TP837 HD4
- TP838 HD5
- TP839 HD6
- TP841 HD7
- TP840 HD8
- TP830 HD9
- TP829 HD10
- TP831 HD11
- TP832 HD12
- TP843 HD13
- TP844 HD14
- TP833 HD15

- TP819 HA0
- TP818 HA1
- TP820 HA2
- TP826 HA3
- TP821 HA4
- TP822 HA5
- TP823 HA6
- TP825 HA7
- TP824 HA8
- TP814 HA9
- TP813 HA10
- TP815 HA11
- TP816 HA12
- TP827 HA13
- TP828 HA14
- TP817 HA15
- TP810 HA16
- TP811 HA17
- TP812 HA18
- TP845 HA19

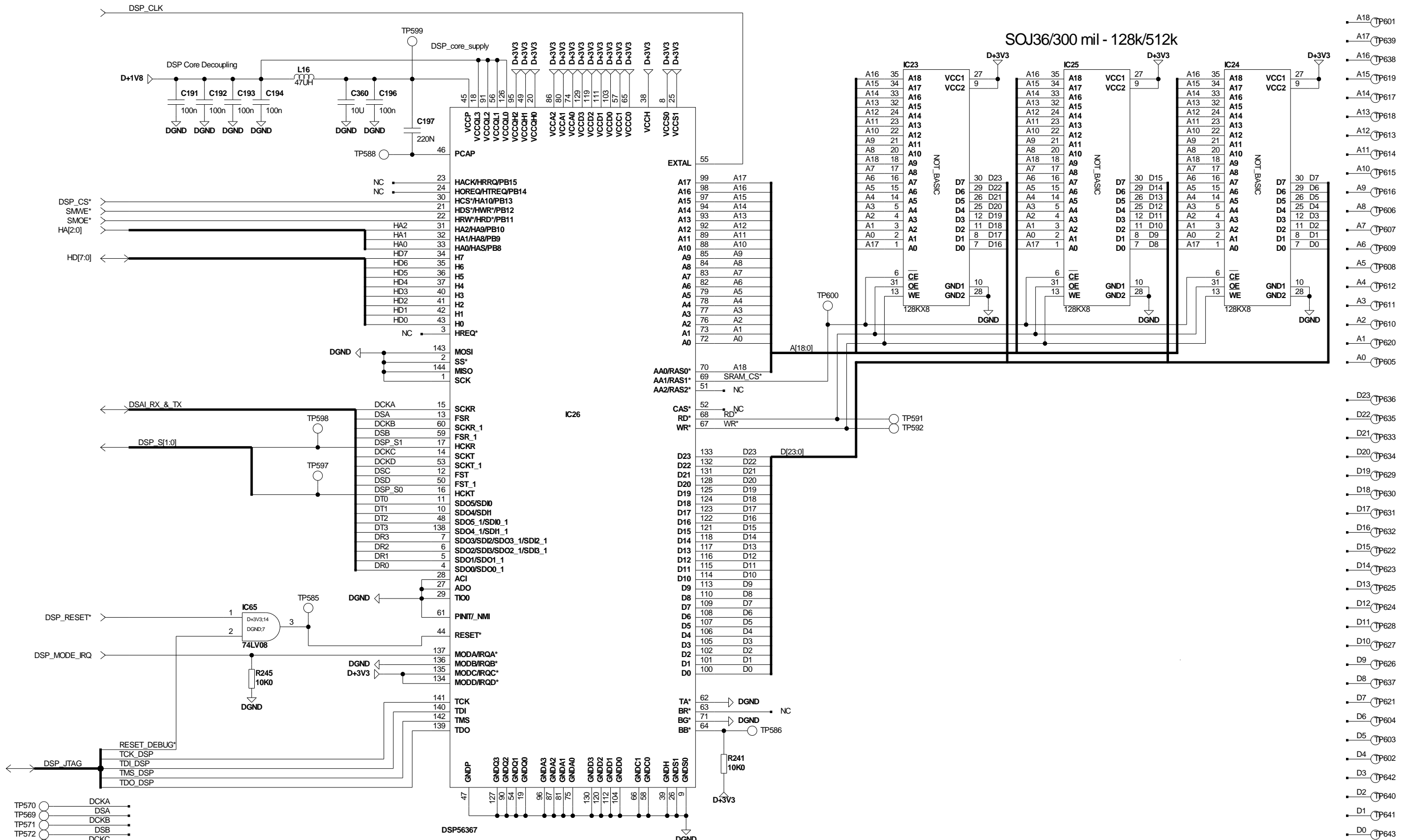

- TP570 DCKA
- TP569 DSA
- TP571 DCKB
- TP572 DSB
- TP573 DCKC
- TP574 DCKD
- TP575 DSC
- TP576 DSD
- TP577 DT0
- TP578 DT1
- TP579 DT2
- TP580 DT3
- TP581 DR3
- TP582 DR2
- TP583 DR1
- TP584 DR0

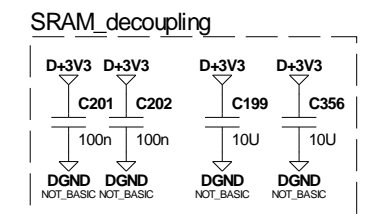
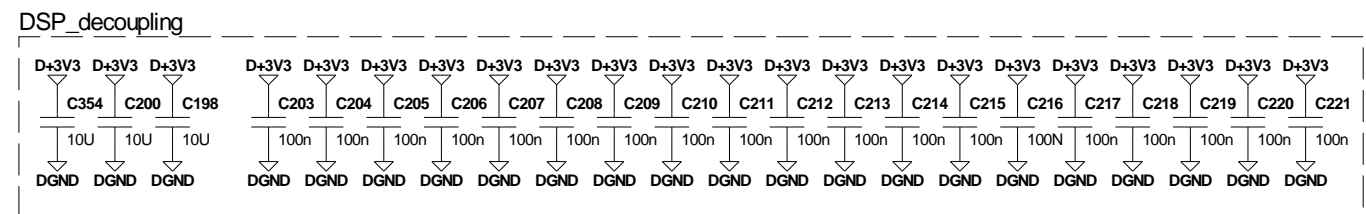

TC Electronic A/S		Designer
		LHOMFA
Title		
EIO3 (IMPACT MOBILE)		Module title
DSP		
Number	Revision	Previous page
P19331	EDB	1
Date	Filename	Page / of
7-1-2009_15:15	DSP	5 / 15

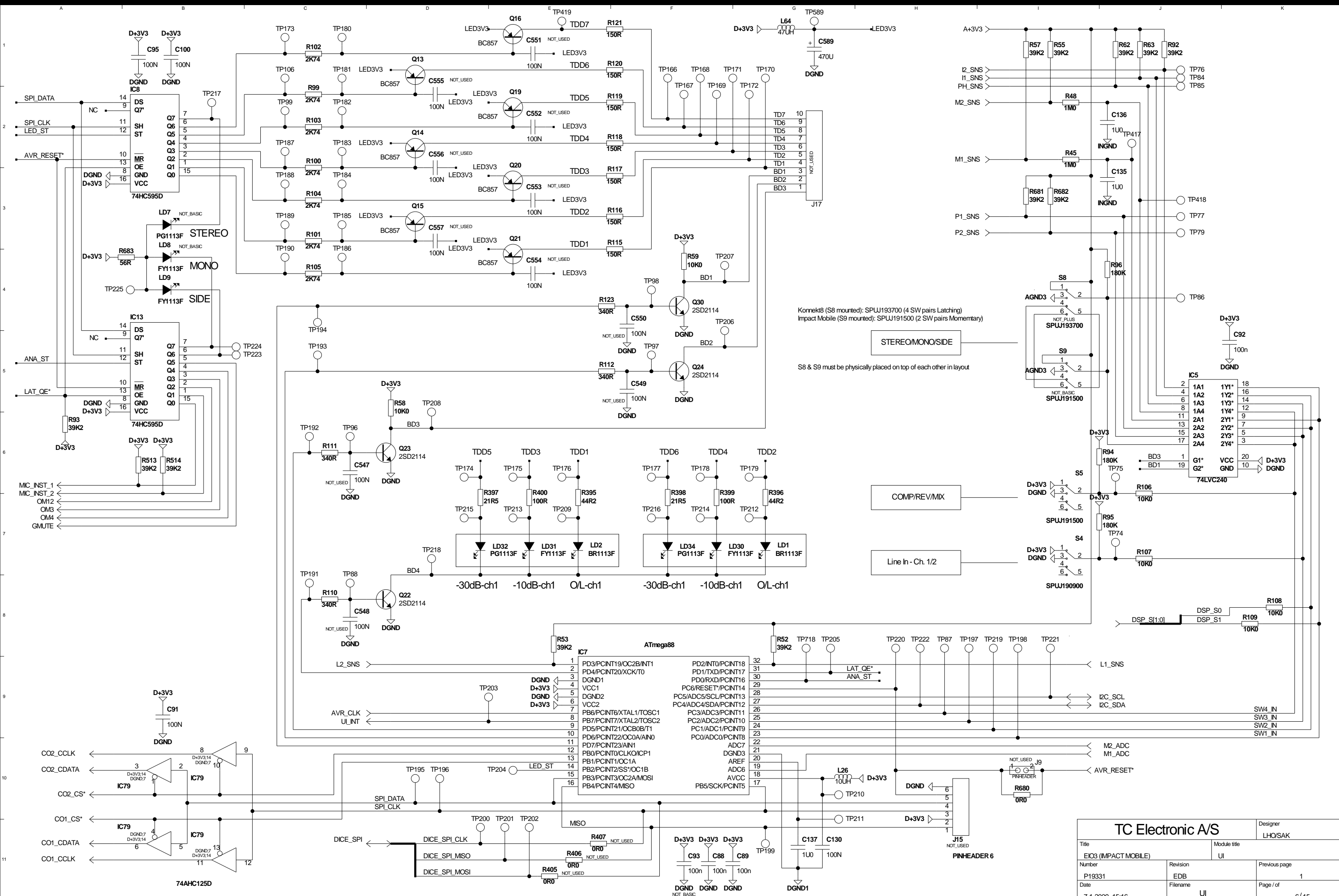

Konnekt8 (S8 mounted): SPUJ193700 (4 SW pairs Latching)
 Impact Mobile (S9 mounted): SPUJ191500 (2 SW pairs Momentary)

S8 & S9 must be physically placed on top of each other in layout

STEREO/MONO/SIDE

COMP/REV/MIX

Line In - Ch. 1/2

TC Electronic A/S		Designer	LHO/SAK
Title	EIO3 (IMPACT MOBILE)	Module title	UI
Number	P19331	Revision	EDB
Date	7-1-2009_15:16	Filename	UI
		Page / of	1 / 15

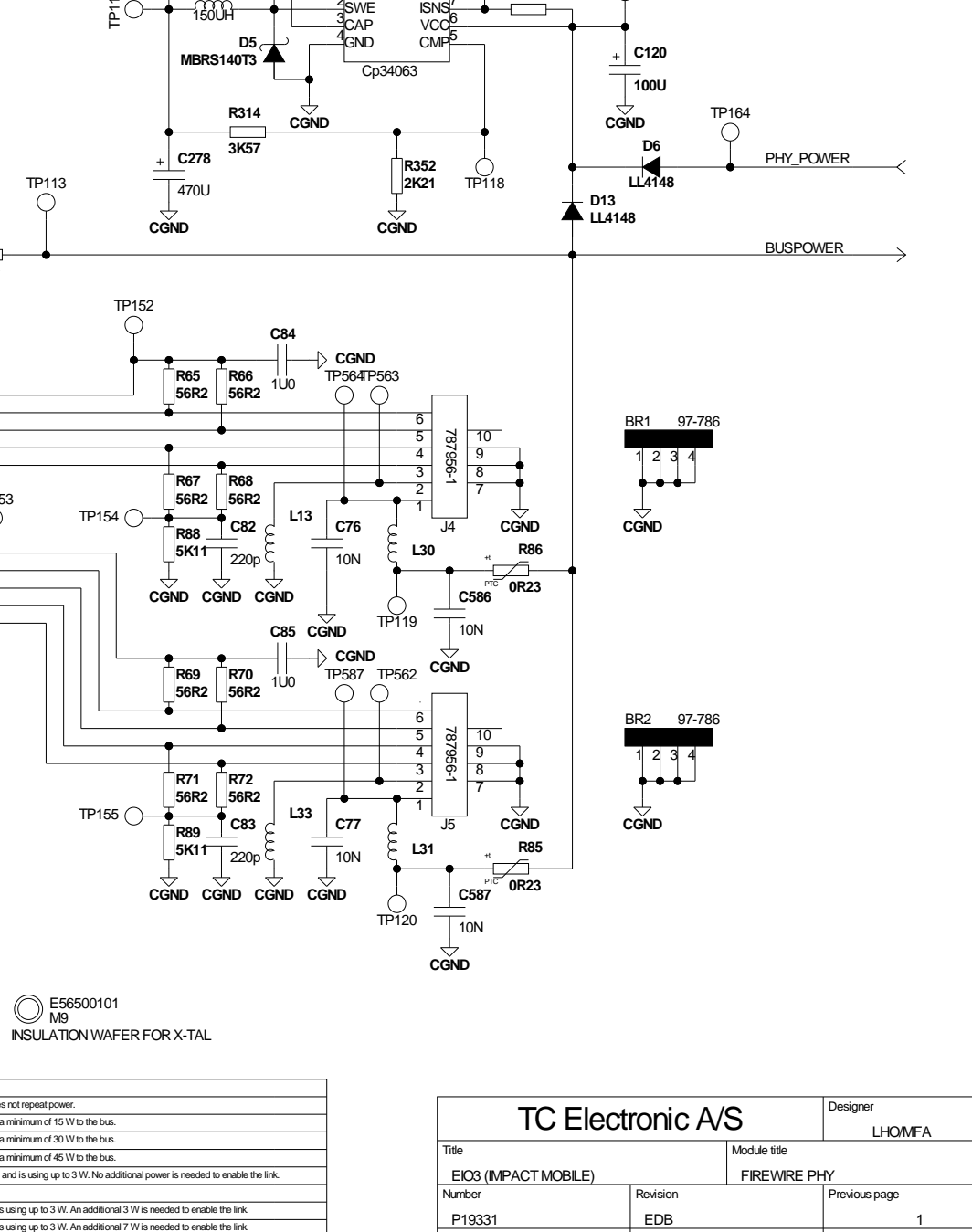
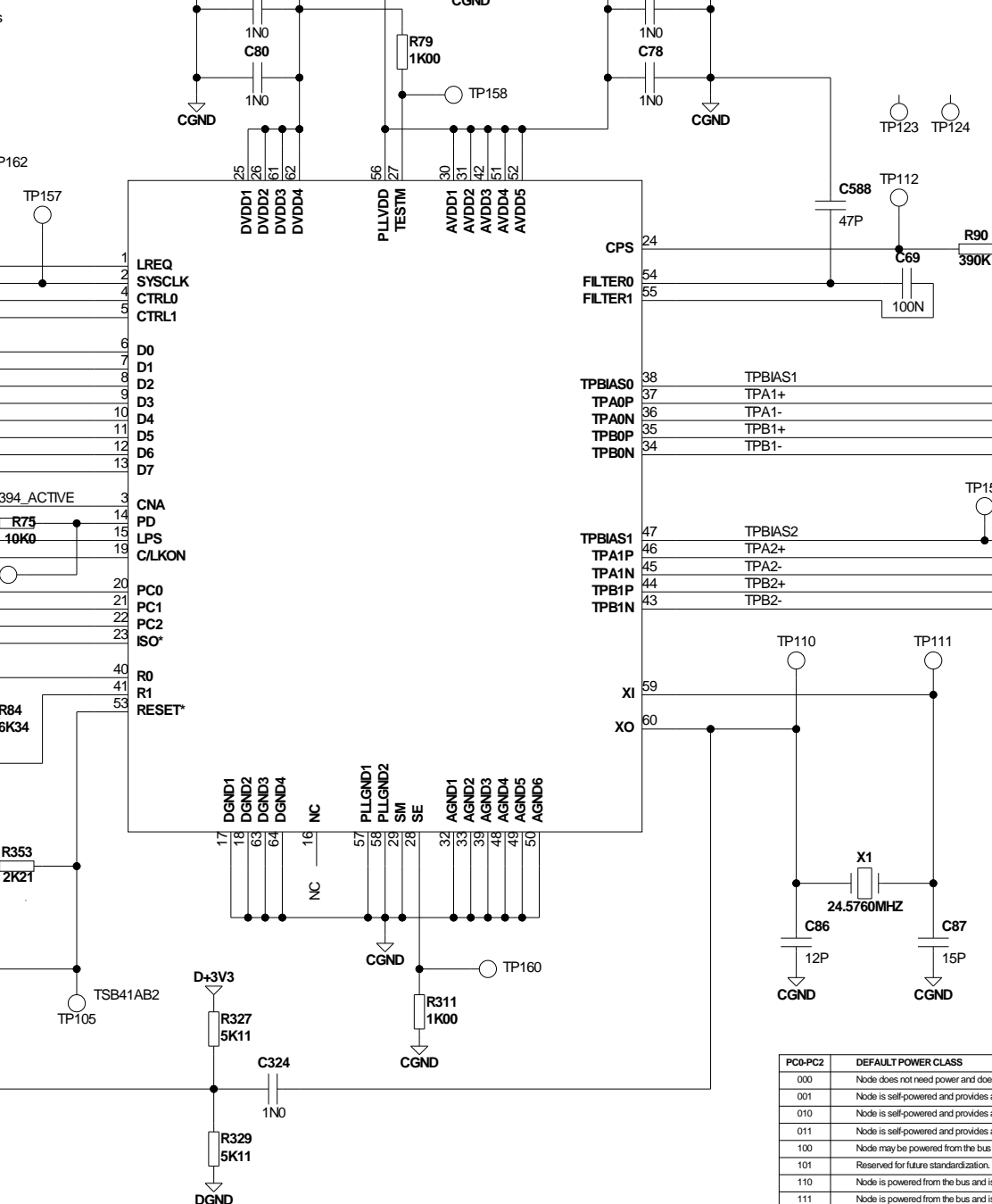
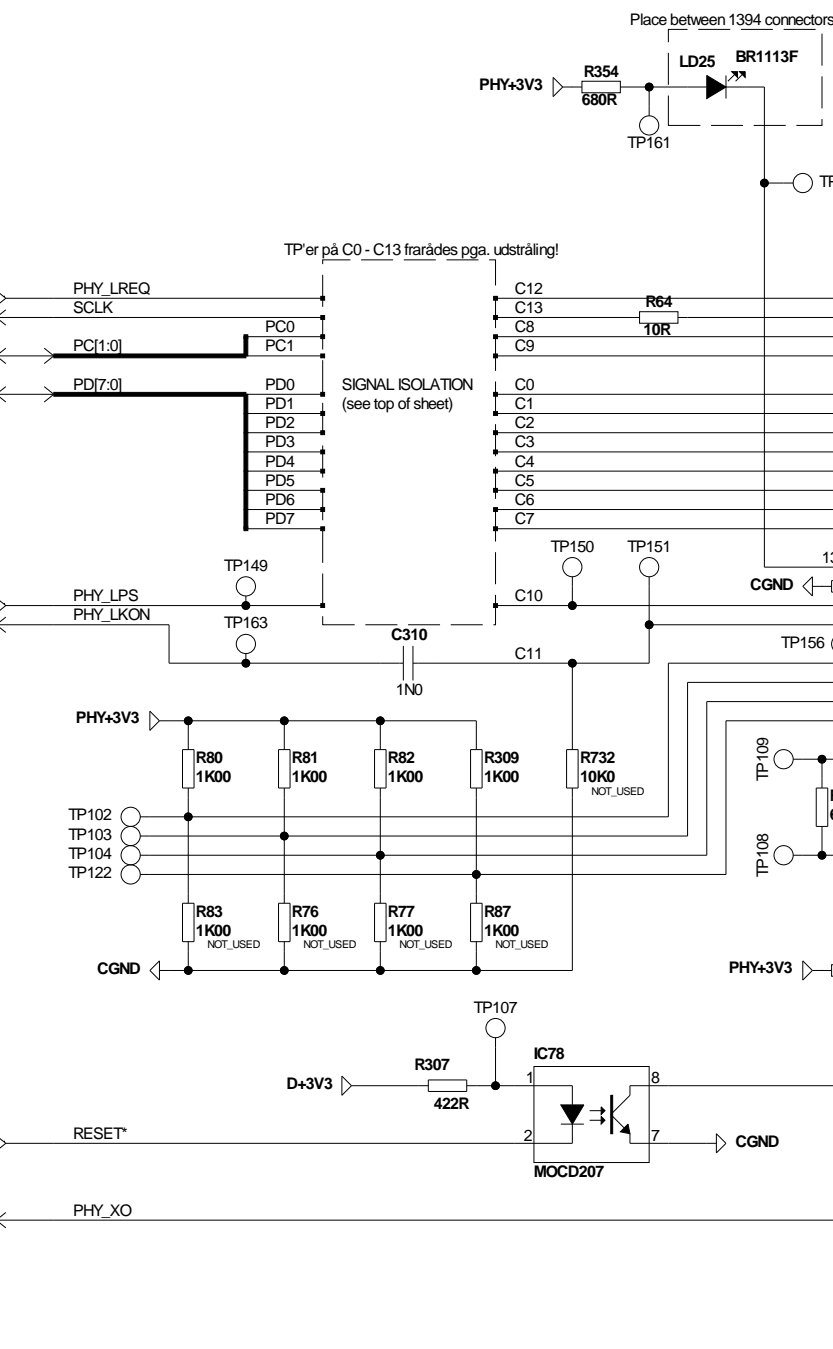
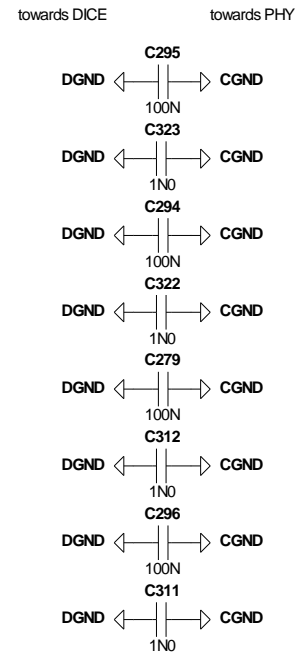
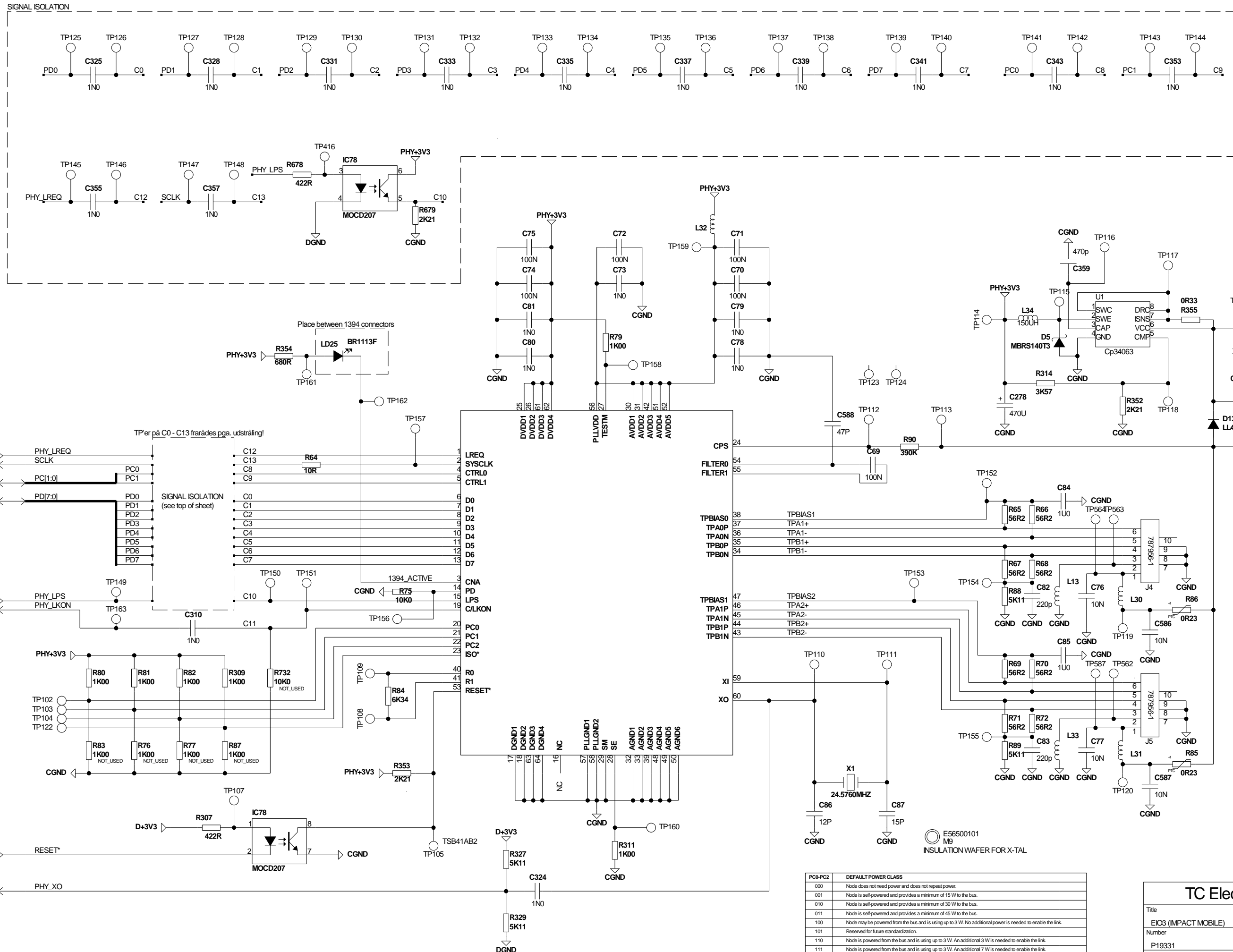

PC0-PC2	DEFAULT POWER CLASS
000	Node does not need power and does not repeat power.
001	Node is self-powered and provides a minimum of 15 W to the bus.
010	Node is self-powered and provides a minimum of 30 W to the bus.
011	Node is self-powered and provides a minimum of 45 W to the bus.
100	Node may be powered from the bus and is using up to 3 W. No additional power is needed to enable the link.
101	Reserved for future standardization.
110	Node is powered from the bus and is using up to 3 W. An additional 3 W is needed to enable the link.
111	Node is powered from the bus and is using up to 3 W. An additional 7 W is needed to enable the link.

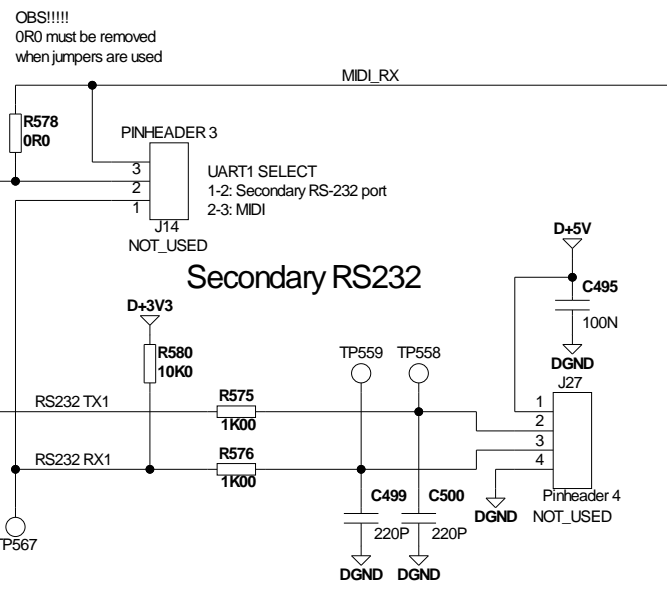
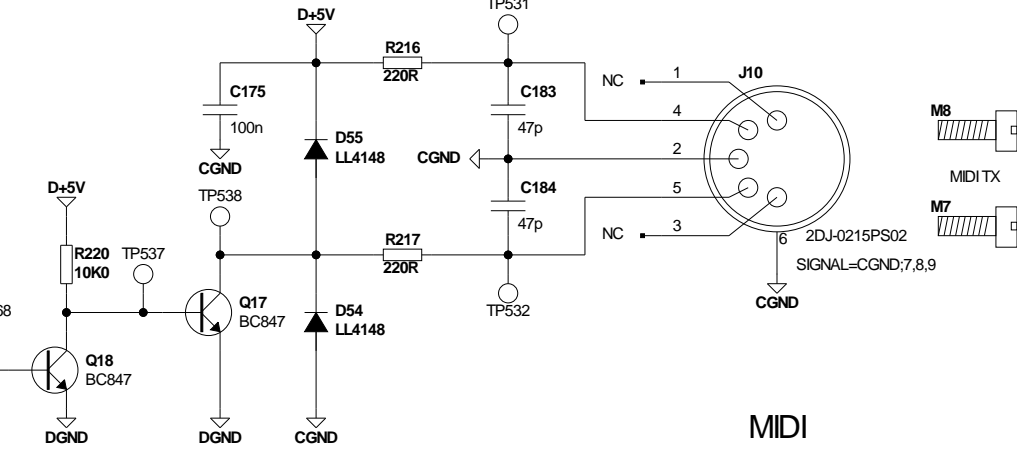
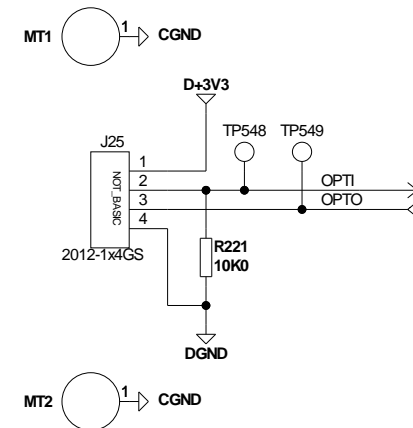
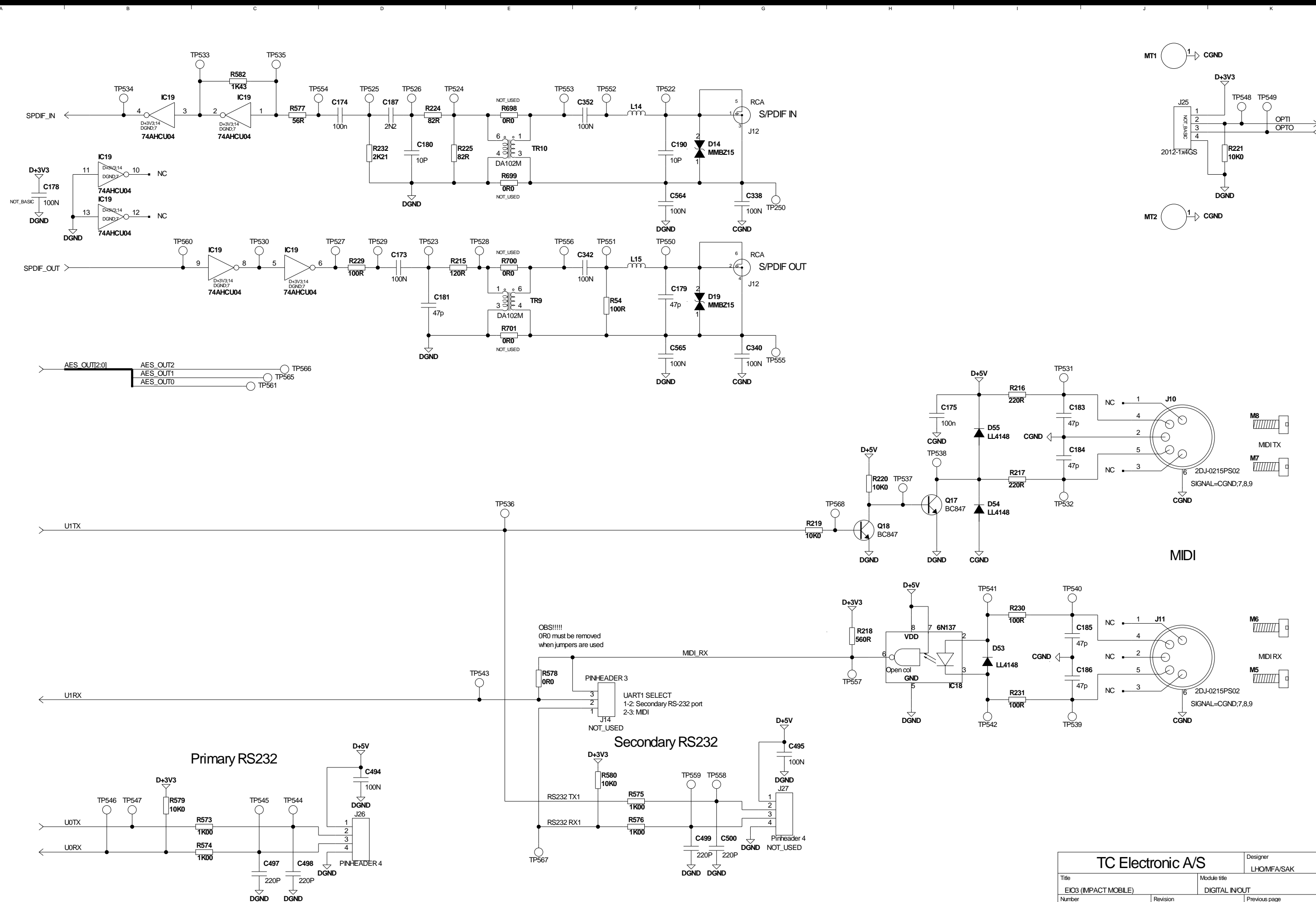

TC Electronic A/S		Designer	LHOMFA/SAK
Title		Module title	
EIO3 (IMPACT MOBILE)		DIGITAL IN/OUT	
Number	Revision	Previous page	
P19331	EDB	1	
Date	Filename	Page / of	
7-1-2009_15:17	DIGITAL_IN_OUT	8 / 15	

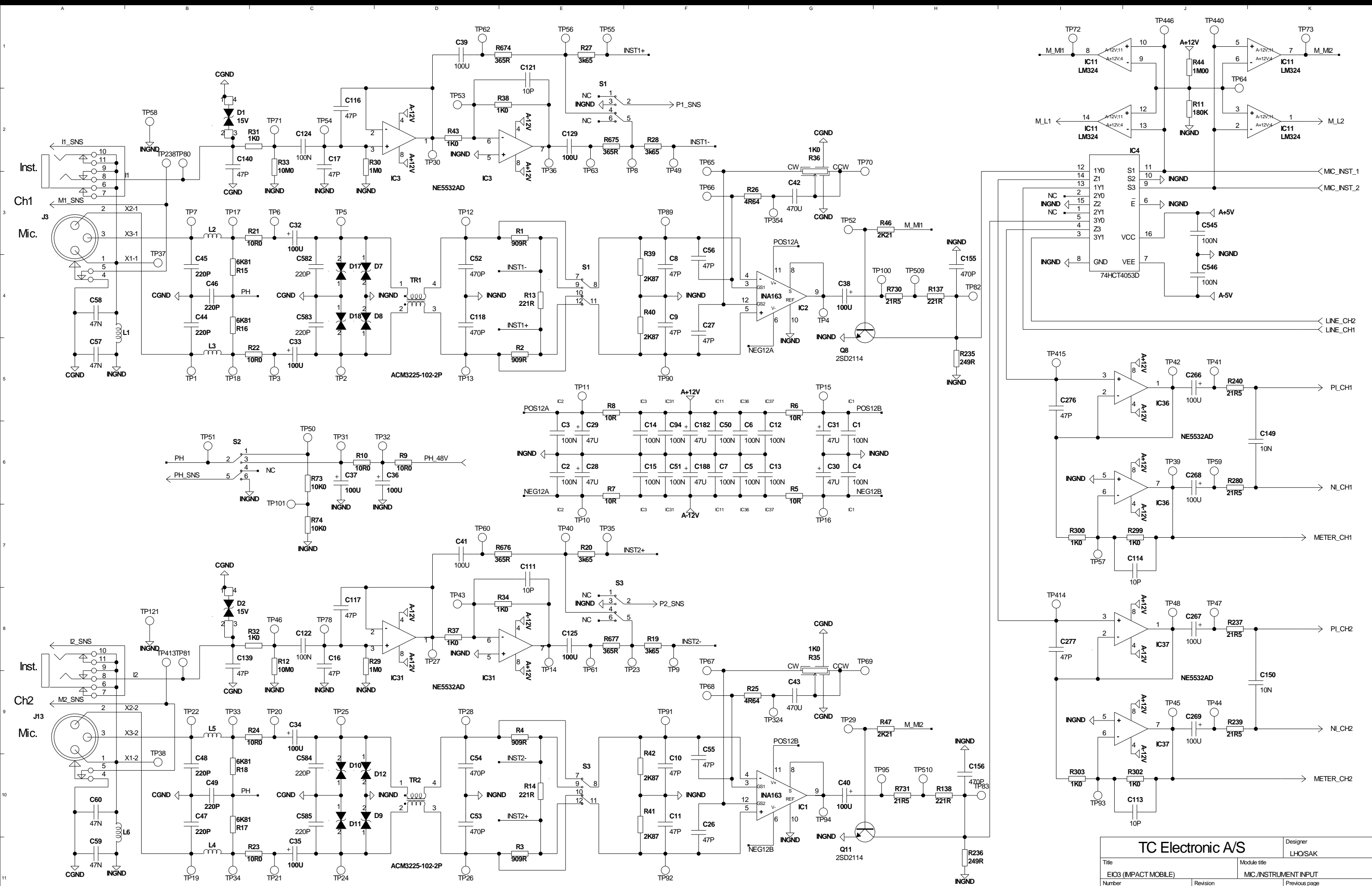

TC Electronic A/S		Designer	LHO/SAK
Title		Module title	
EIO3 (IMPACT MOBILE)		MIC/INSTRUMENT INPUT	
Number	Revision	Previous page	
P19331	EDB	1	
Date	Filenam	Page / of	
7-1-2009_15:16	MIC_IN	9 / 15	

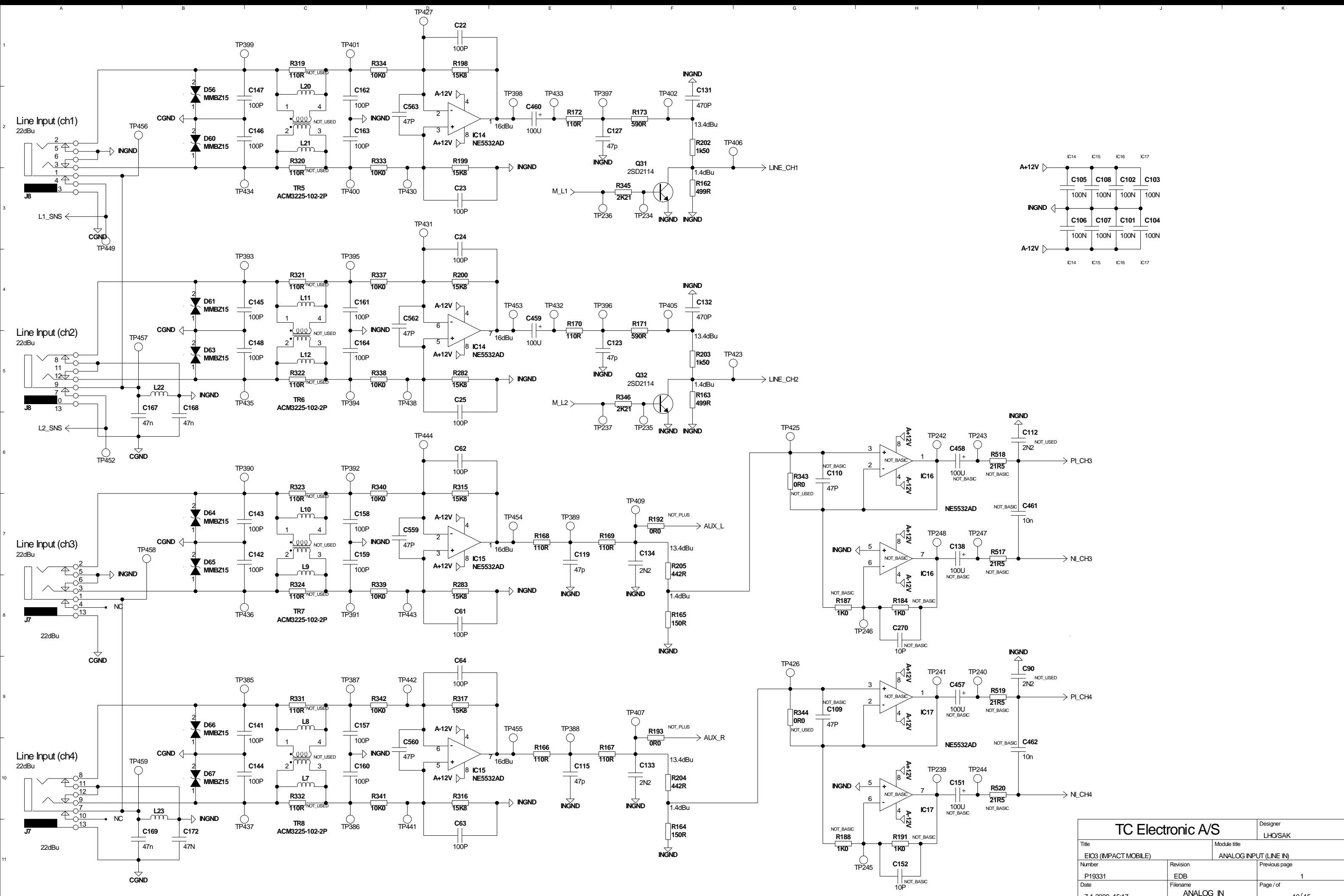

A+12V	IC14	IC15	IC16	IC17
	C105	C108	C102	C103
INGND	100N	100N	100N	100N
	C106	C107	C101	C104
A-12V	100N	100N	100N	100N
	IC14	IC15	IC16	IC17

TC Electronic A/S		Designer
		LHO/SAK
Title	Module title	
EIO3 (IMPACT MOBILE)	ANALOG INPUT (LINE IN)	
Number	Revision	Previous page
P19331	EDB	1
Date	Filename	Page / of
7-1-2009_15:17	ANALOG_IN	10 / 15

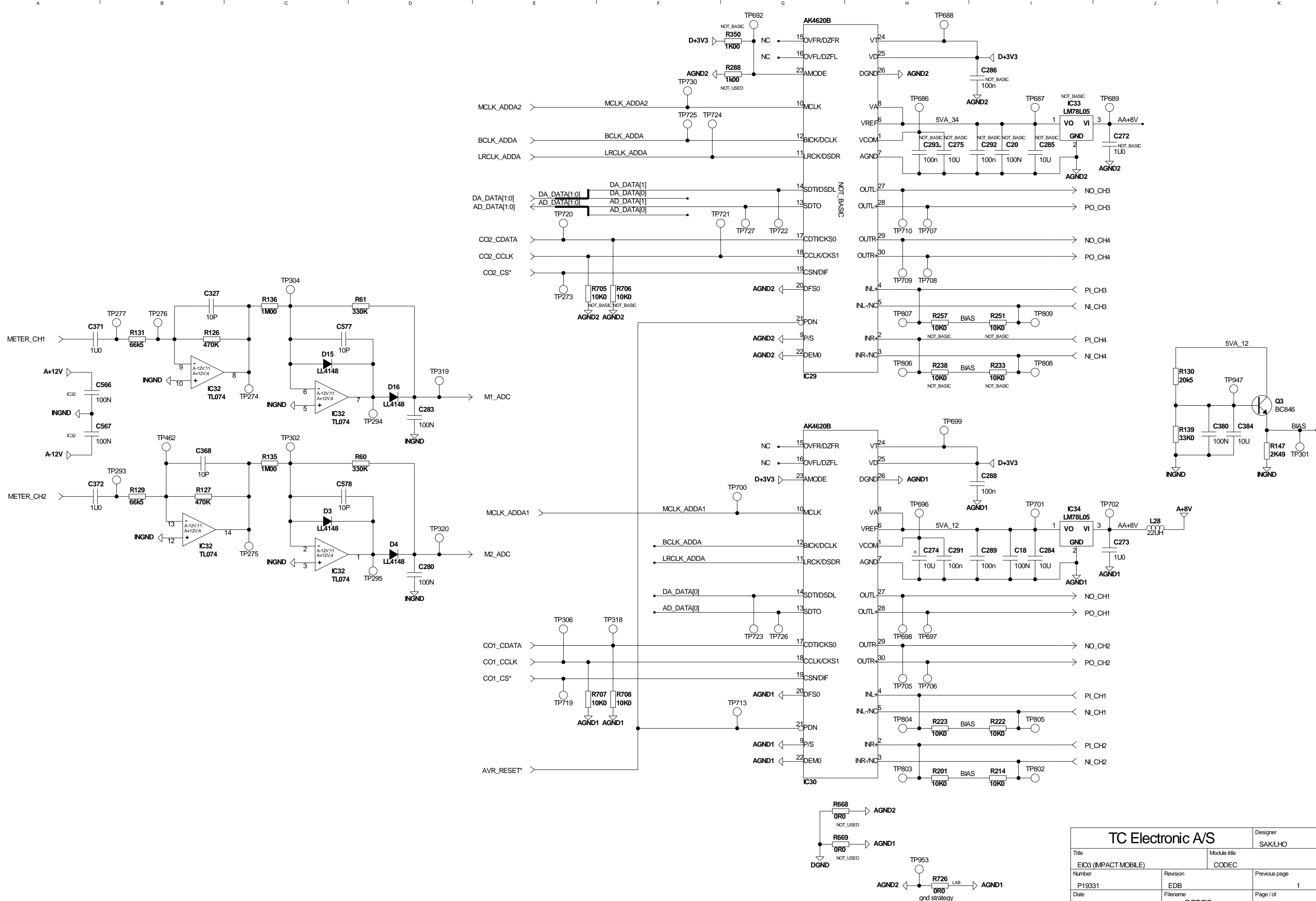

TC Electronic A/S		Designer SAK/LHO
Title EIO3 (IMPACT MOBILE)	Module title CODEC	
Number P19331	Revision EDB	Previous page 1
Date 7-1-2009_15:18	Filename CODEC	Page / of 11 / 15

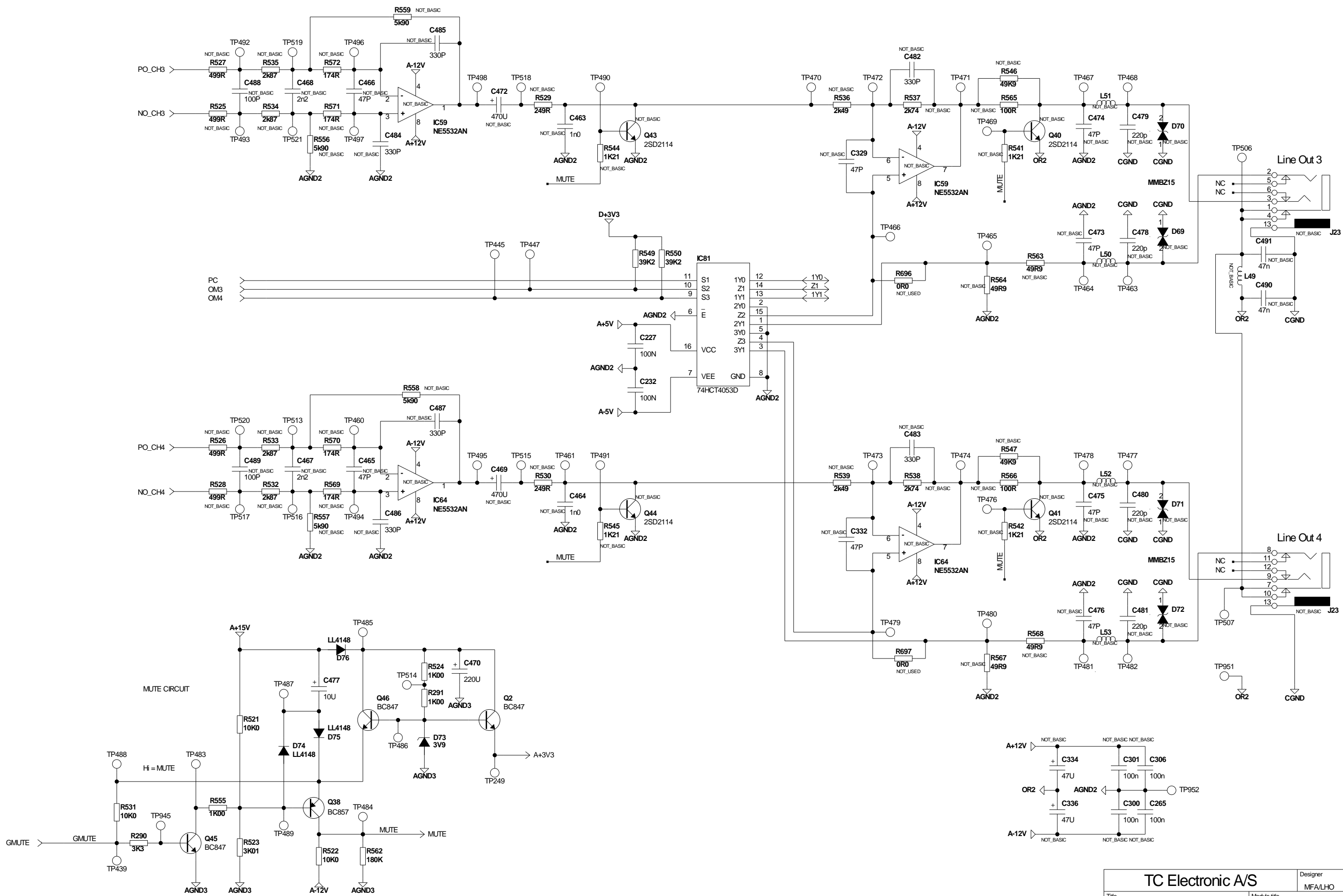

TC Electronic A/S		Designer	MFA/LHO
Title		Module title	
EIO3 (IMPACT MOBILE)		LINE_OUT	
Number	Revision	Previous page	
P19331	EDB	1	
Date	Filename	Page / of	
7-1-2009_15:17	LINE_OUT	12 / 15	

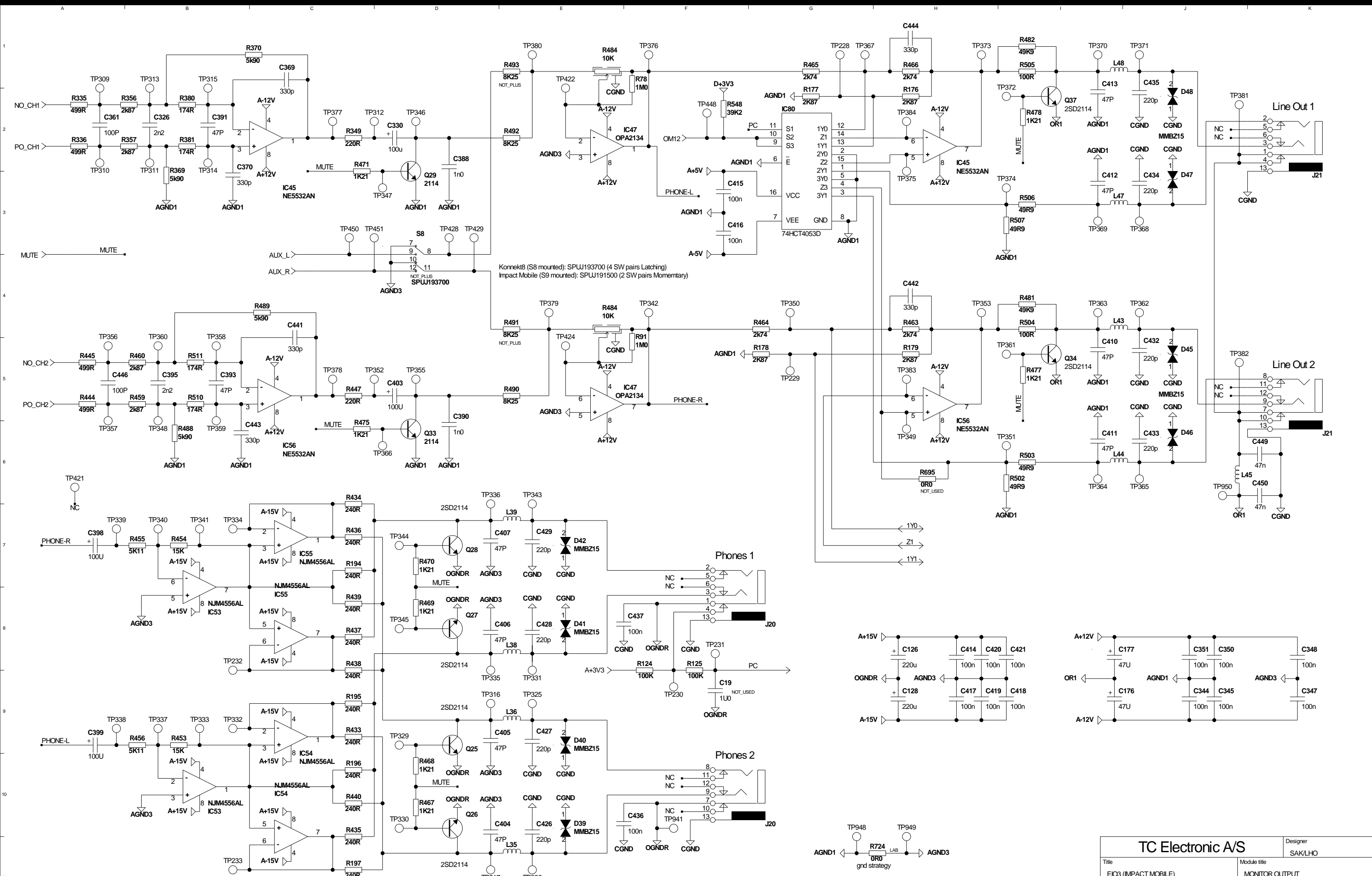

Konnekt8 (S8 mounted): SPU193700 (4 SW pairs Latching)
 Impact Mobile (S9 mounted): SPU191500 (2 SW pairs Momentary)

TC Electronic A/S		Designer SAK/LHO
Title EIO3 (IMPACT MOBILE)	Module title MONITOR OUTPUT	
Number P19331	Revision EDB	Previous page 1
Date 7-1-2009_15:17	Filename MONITOR_OUT	Page / of 13 / 15

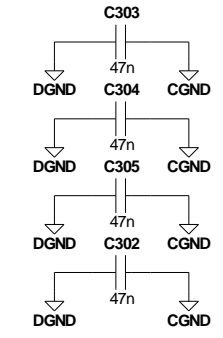
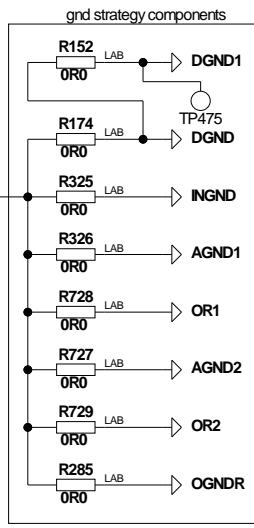
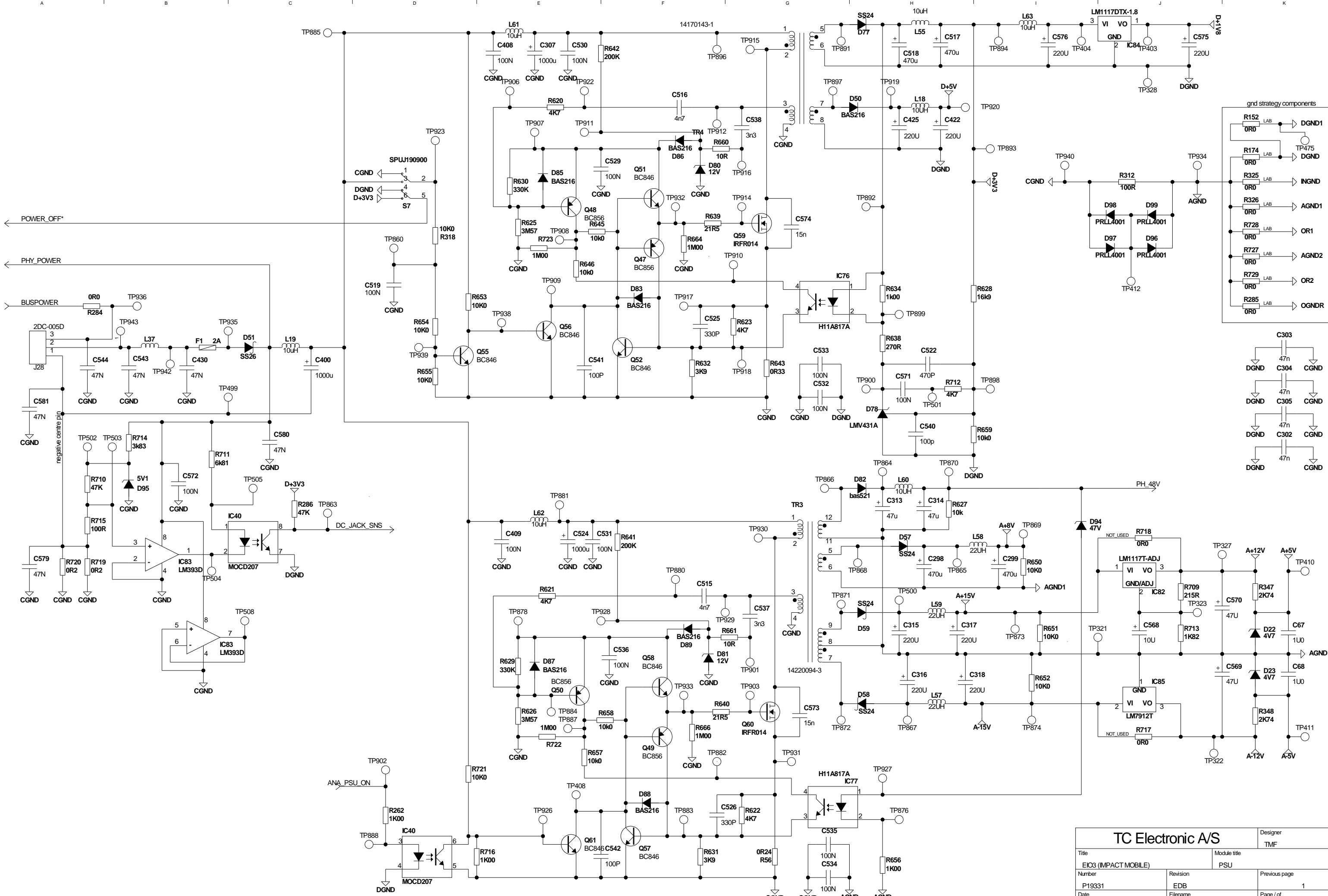

TC Electronic A/S		Designer	TMF
Title		Module title	
EIO3 (IMPACT MOBILE)		PSU	
Number	Revision	Previous page	
P19331	EDB	1	
Date	Filename	Page / of	
7-1-2009_15:18	PSU	14 / 15	

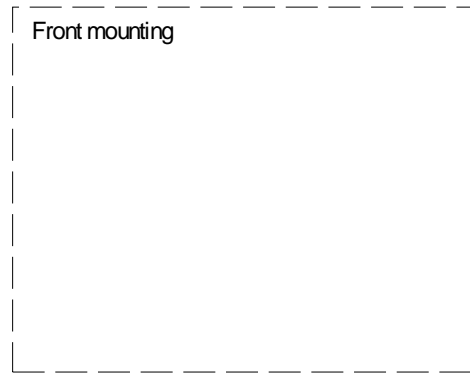
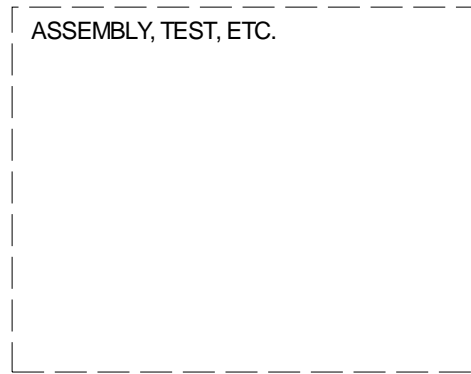
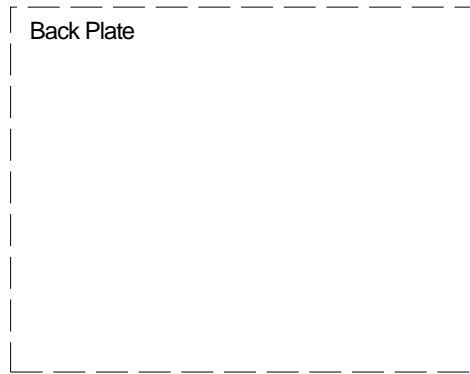
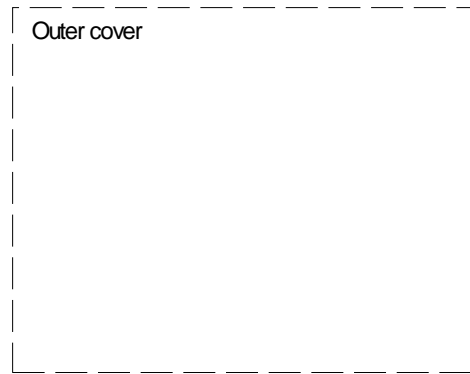
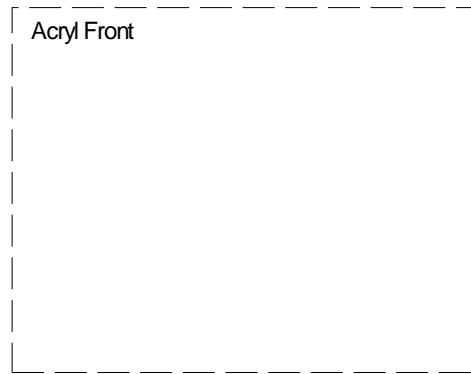
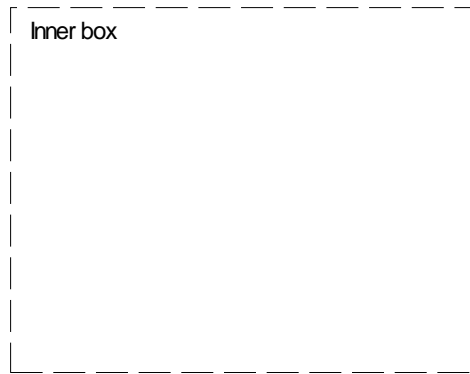

TC Electronic A/S

Designer
LHO

Title	EIO3 (IMPACT MOBILE)		Module title	MECHANICAL
-------	----------------------	--	--------------	------------

Number	P19331	Revision	EDB	Previous page	1
--------	--------	----------	-----	---------------	---

Date	7-1-2009_15:16	Filename	MECHANICAL	Page / of	15 / 15
------	----------------	----------	------------	-----------	---------