

EIO2 MAINBOARD

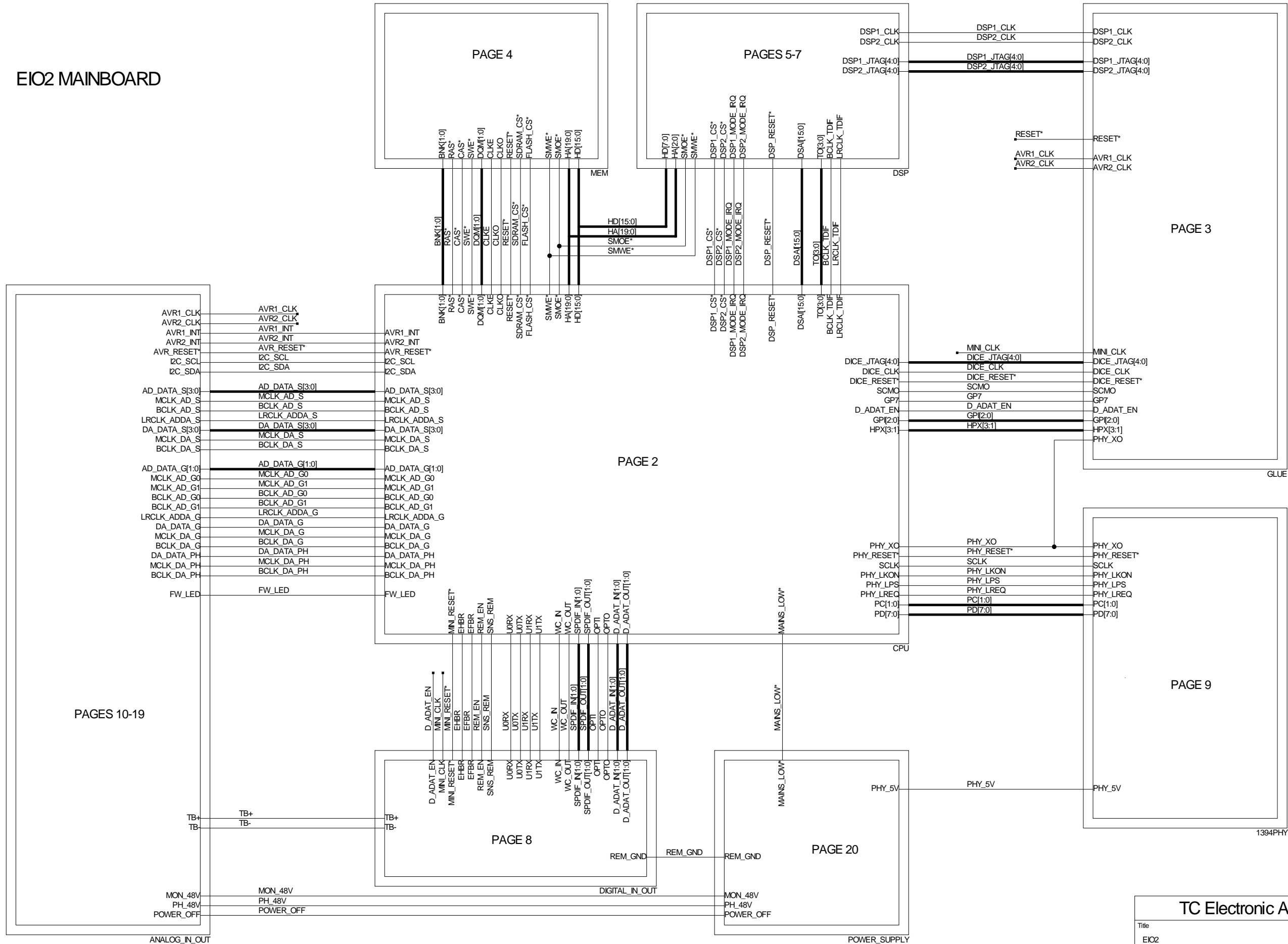

M1
P19321-C

TC Electronic A/S		Designer MFA/LHO/CGF
Title EIO2	Module title TOP	
Number P19321	Revision CAE	Previous page NONE
Date 4-15-2008_9:25	Filename P19321-C	Page / of 1 / 20

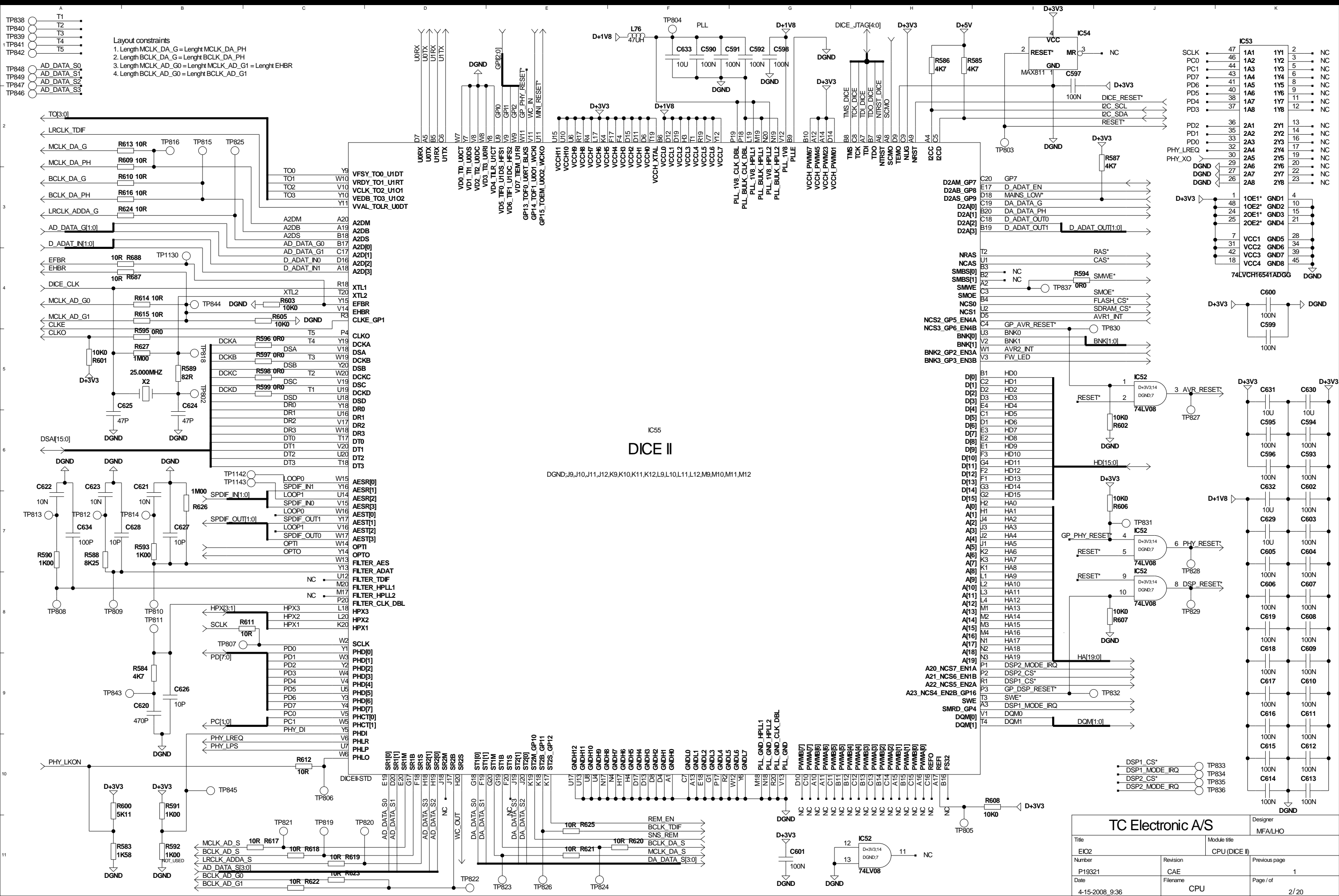

TC Electronic A/S		Designer	MFA/LHO
Title	EIO2	Module title	CPU (DICE II)
Number	P19321	Revision	CAE
Date	4-15-2008_9:36	Filename	CPU
		Previous page	1
		Page / of	2 / 20

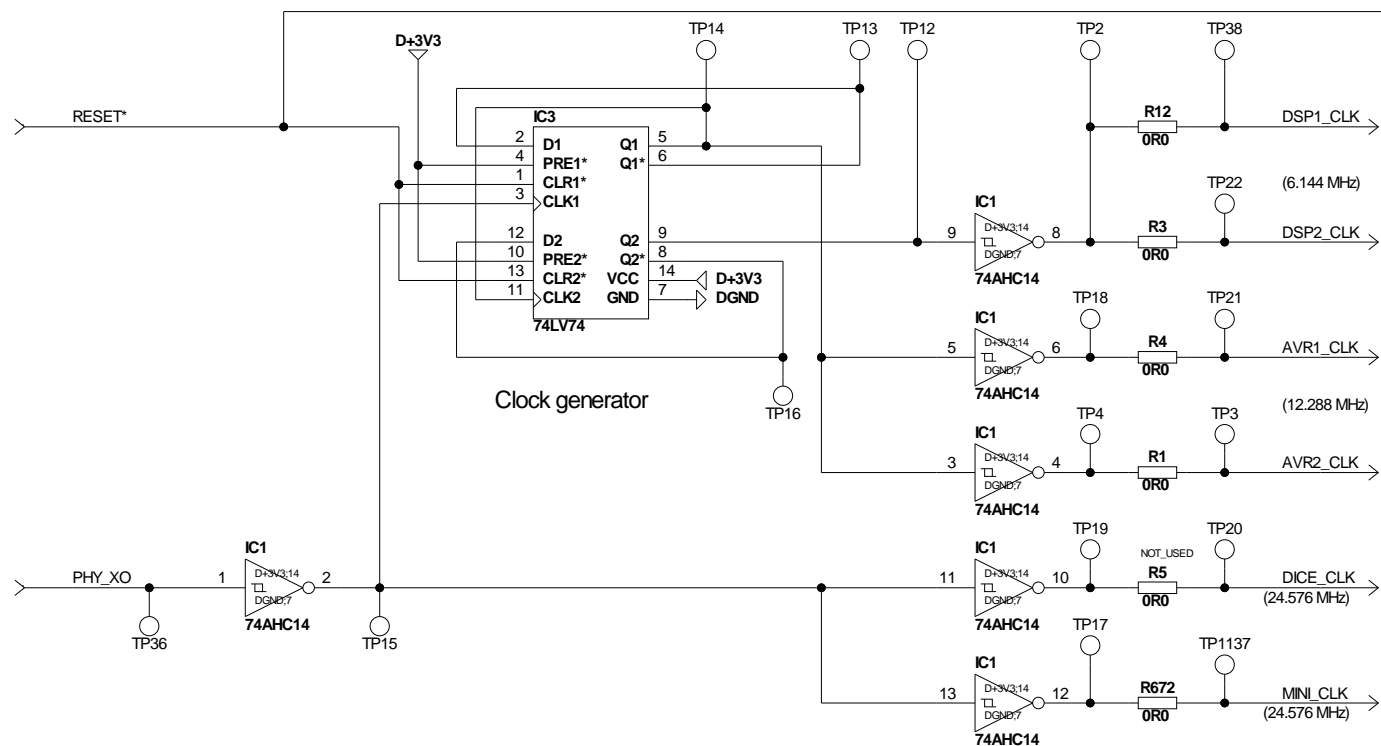

Layout request
Add net-name @ TP's for clock's and other "important" signals

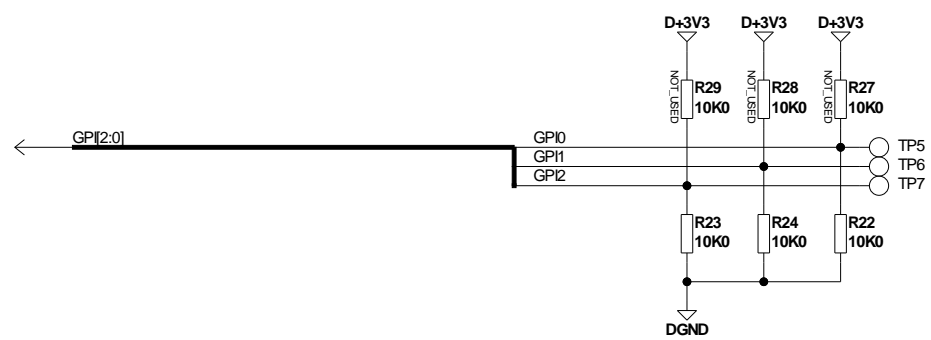

EIO2 Variant Control

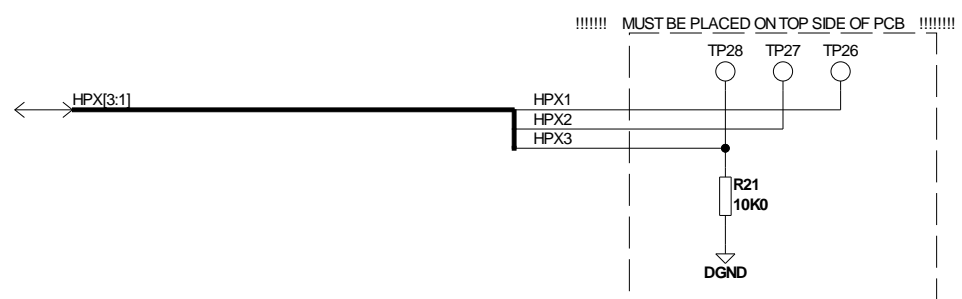

HPLL external pins

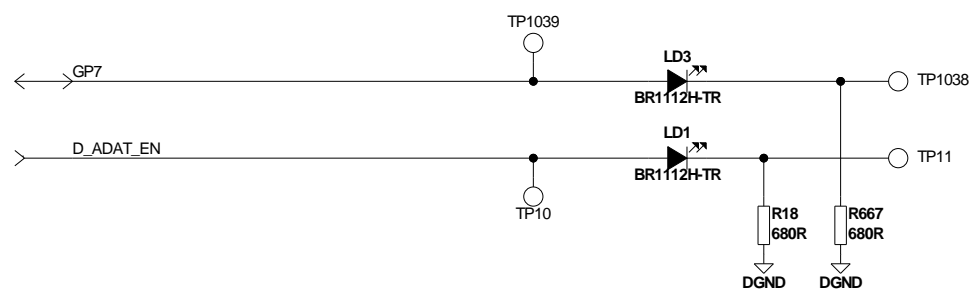

Debug LEDs

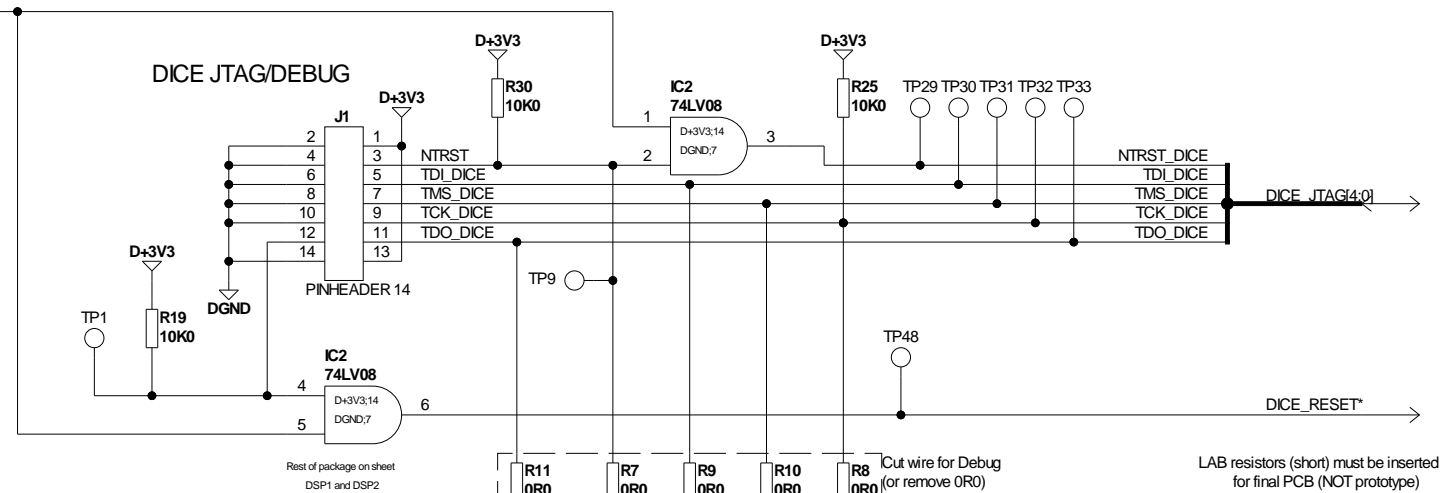

DSP2 JTAG/Debug

DSP1 JTAG/Debug and Boundary Scan

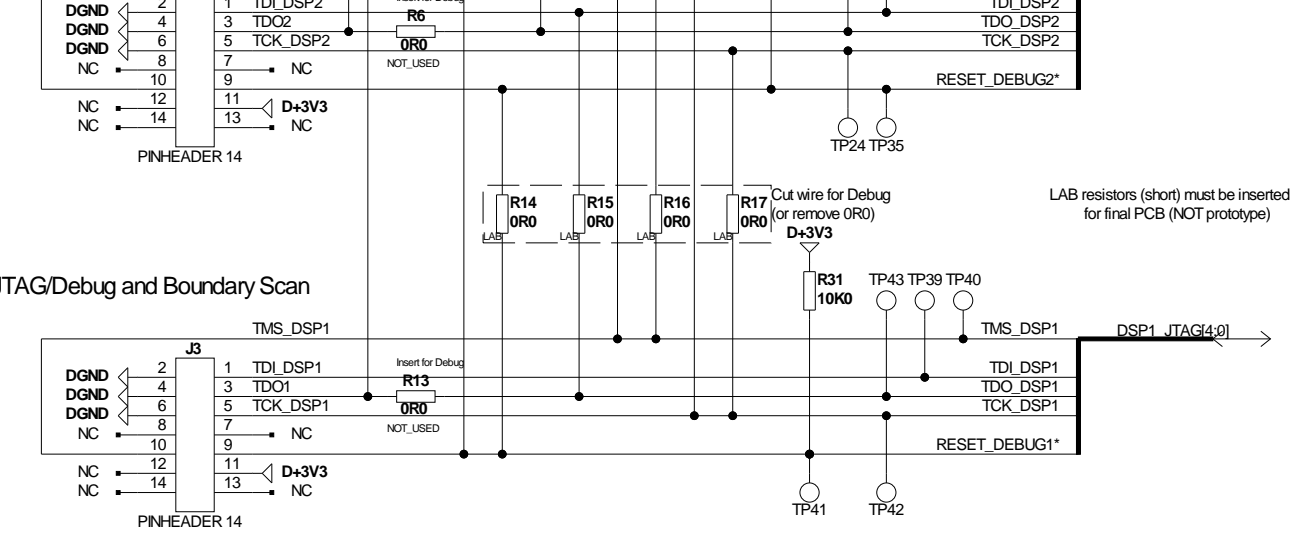

DICE SCAN MODE

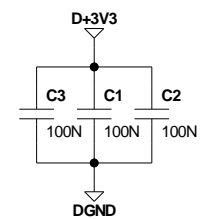

TC Electronic A/S		Designer MFA
Title EIO2	Module title GLUE	Previous page 1
Number P19321	Revision CAE	Page / of 3 / 20
Date 4-15-2008_9:25	Filename GLUE	

Host Memory

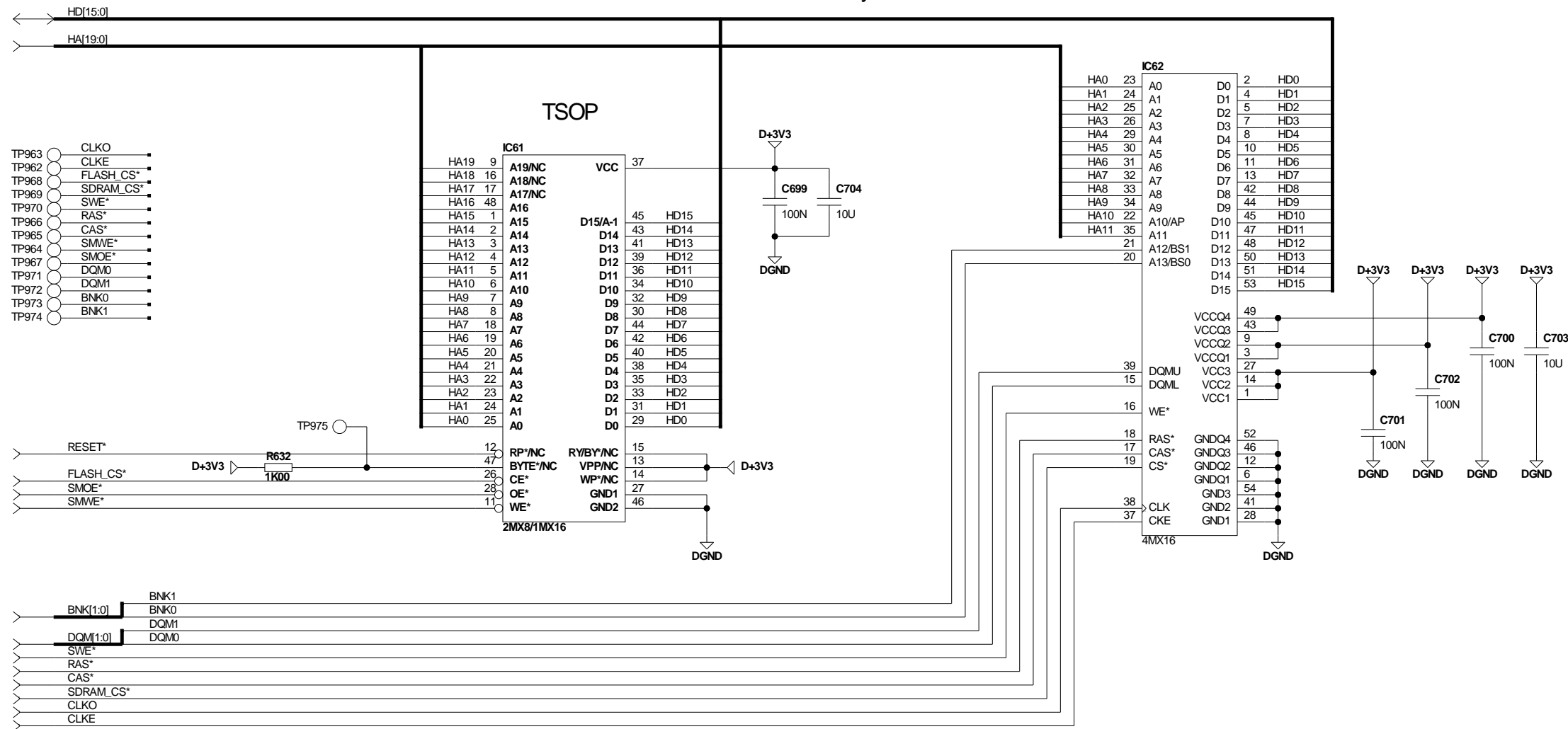

- TP951 HD0
- TP950 HD1
- TP952 HD2
- TP958 HD3
- TP953 HD4
- TP954 HD5
- TP955 HD6
- TP957 HD7
- TP956 HD8
- TP946 HD9
- TP945 HD10
- TP947 HD11
- TP948 HD12
- TP959 HD13
- TP960 HD14
- TP949 HD15
- TP935 HA0
- TP934 HA1
- TP936 HA2
- TP942 HA3
- TP937 HA4
- TP938 HA5
- TP939 HA6
- TP941 HA7
- TP940 HA8
- TP930 HA9
- TP929 HA10
- TP931 HA11
- TP932 HA12
- TP943 HA13
- TP944 HA14
- TP933 HA15
- TP926 HA16
- TP927 HA17
- TP928 HA18
- TP961 HA19

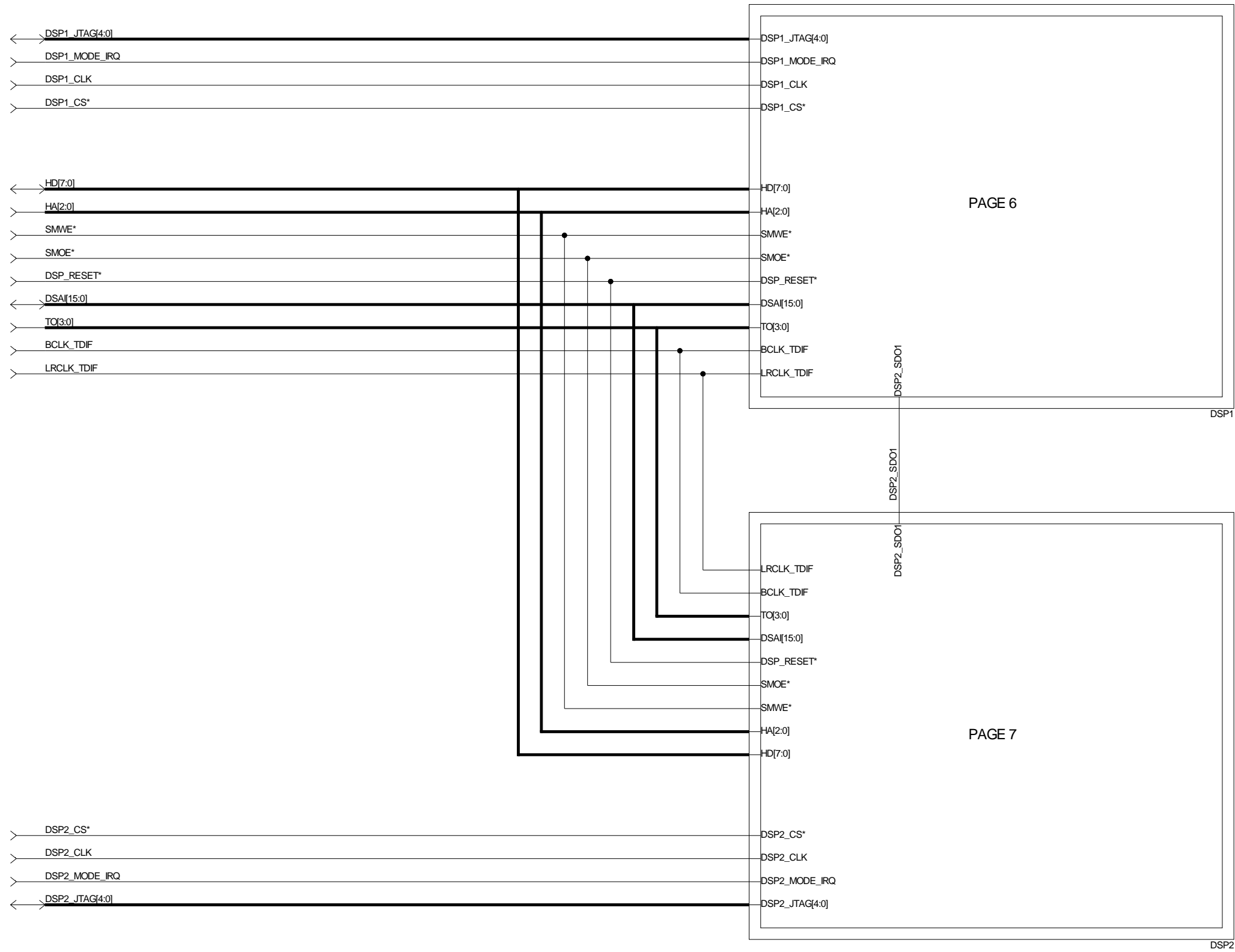

PAGE 6

PAGE 7

TC Electronic A/S		Designer MFA
Title EIO2	Module title DSP	
Number P19321	Revision CAE	Previous page 1
Date 4-15-2008_9:37	Filename DSP	Page / of 5 / 20

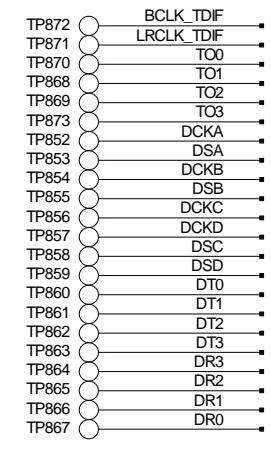
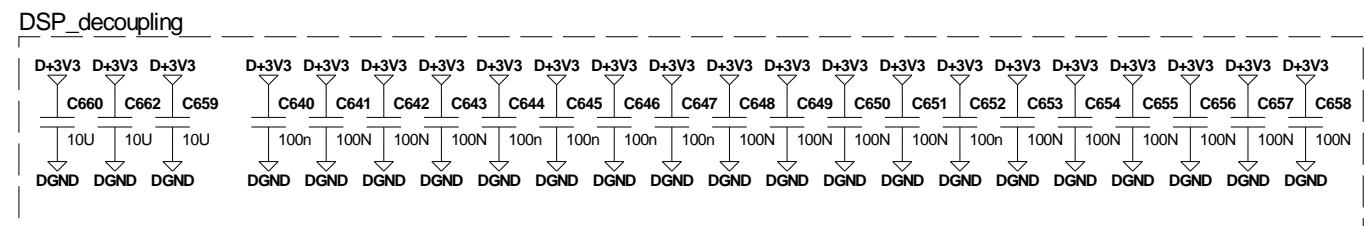
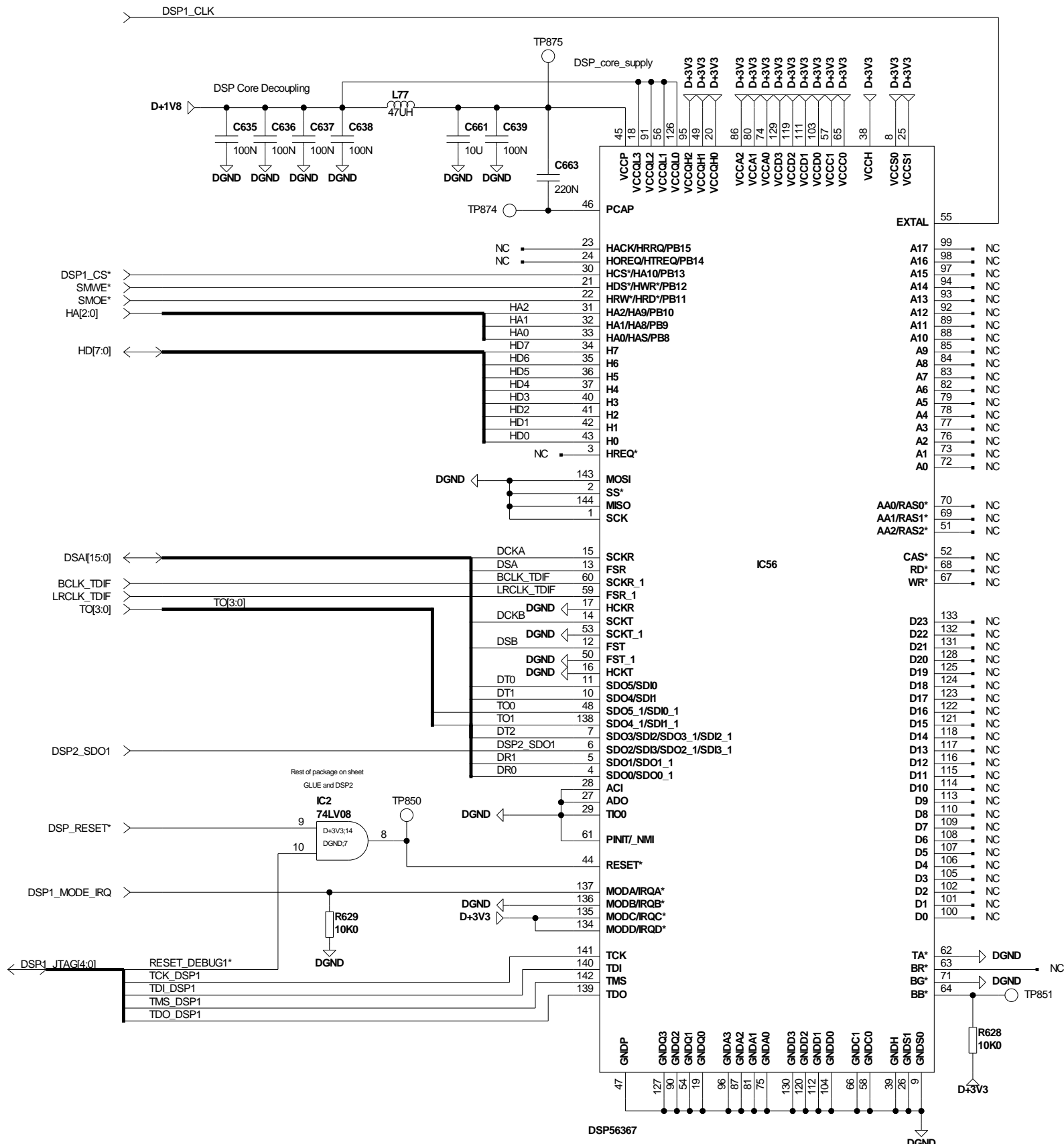

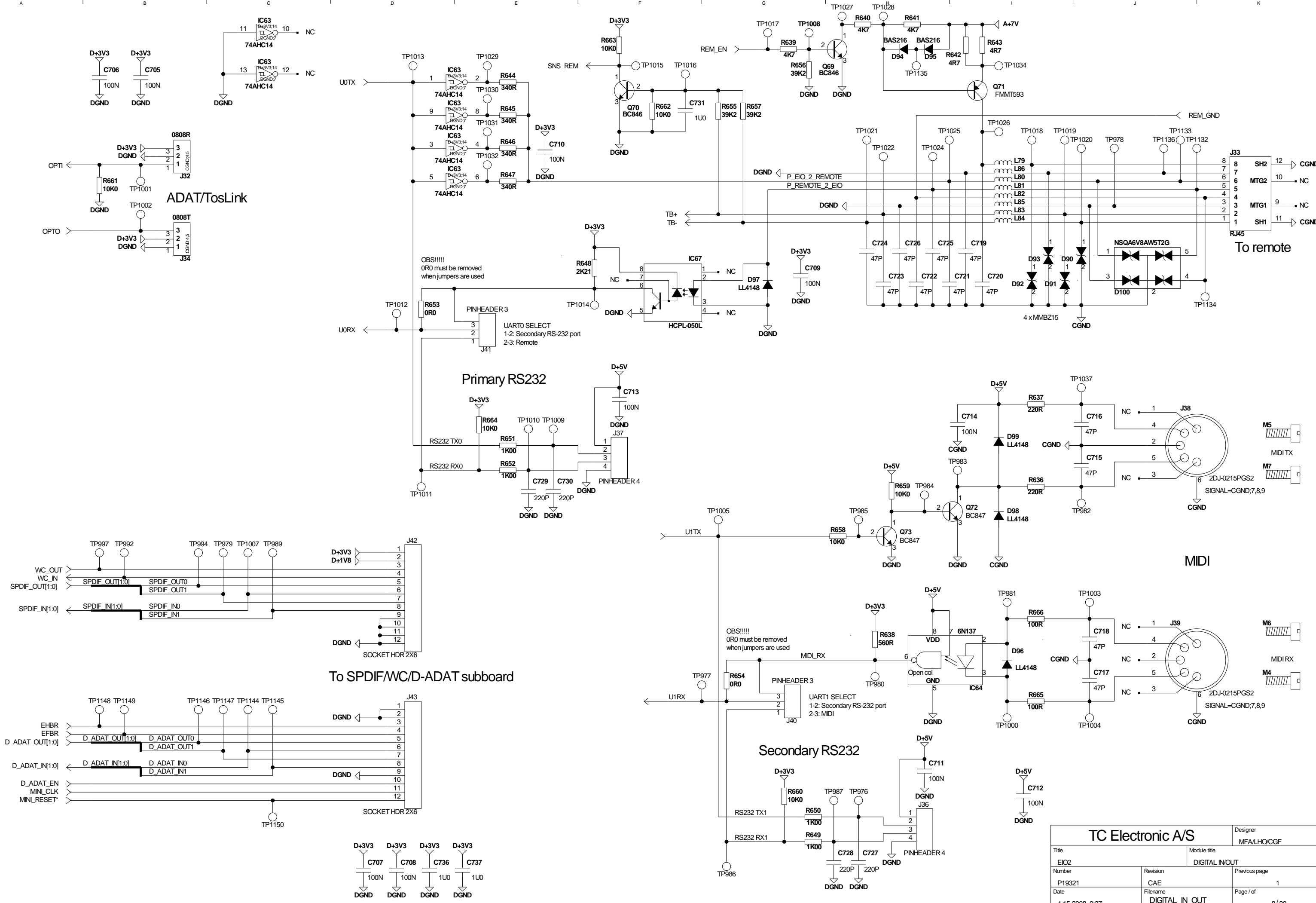

TC Electronic A/S		Designer	MFA/LHO/CGF
Title	EIO2	Module title	DIGITAL IN/OUT
Number	P19321	Revision	CAE
Date	4-15-2008_9:37	Filename	DIGITAL_IN_OUT
		Previous page	1
		Page / of	8 / 20

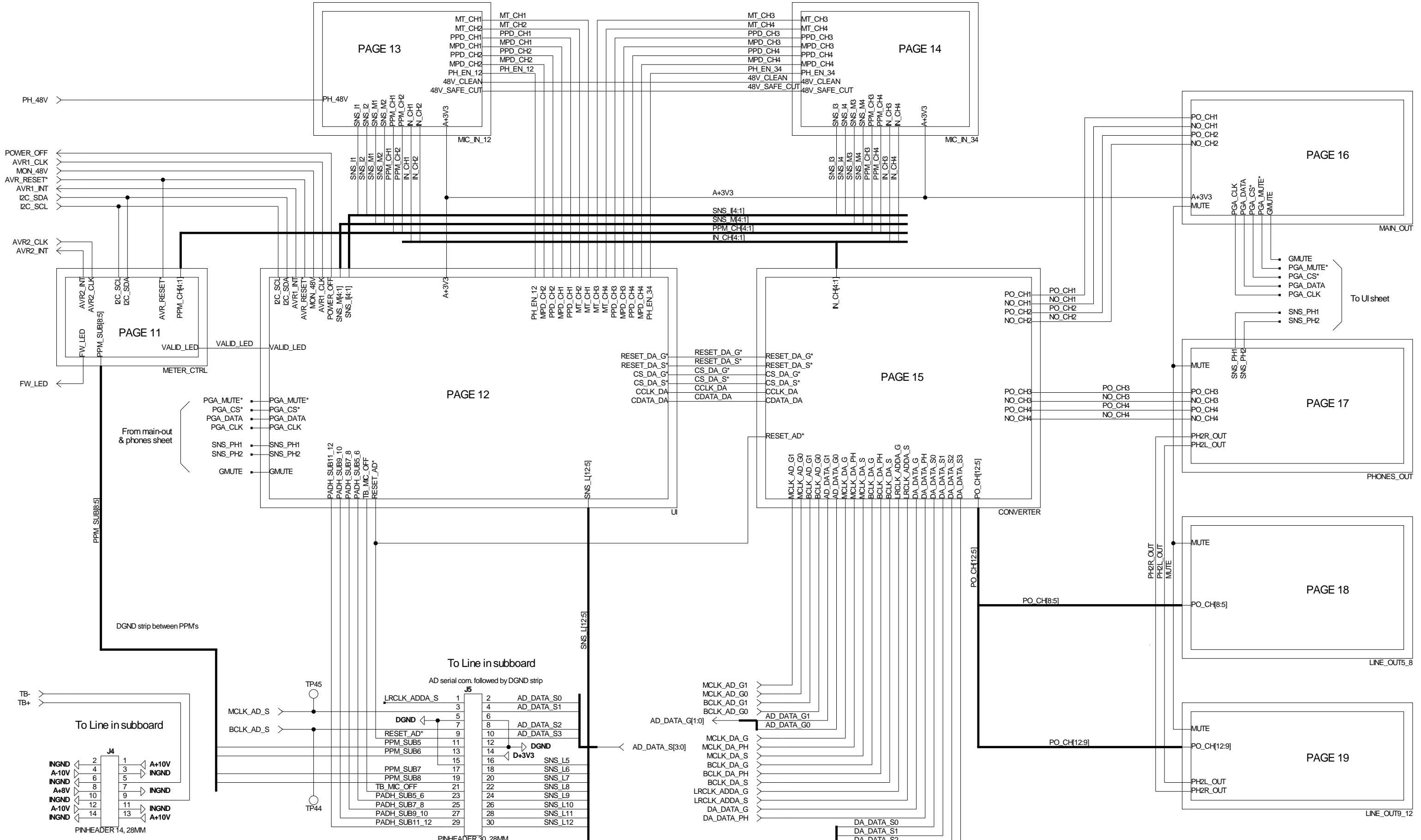

TC Electronic A/S		Designer	MFA
Title		Module title	
EIQ2		ANALOG IN/OUT TOP	
Number	Revision	CAE	Previous page
P19321			1
Date	Filename	Page / of	
4-15-2008_9:26	ANALOG_IN_OUT	10 / 20	

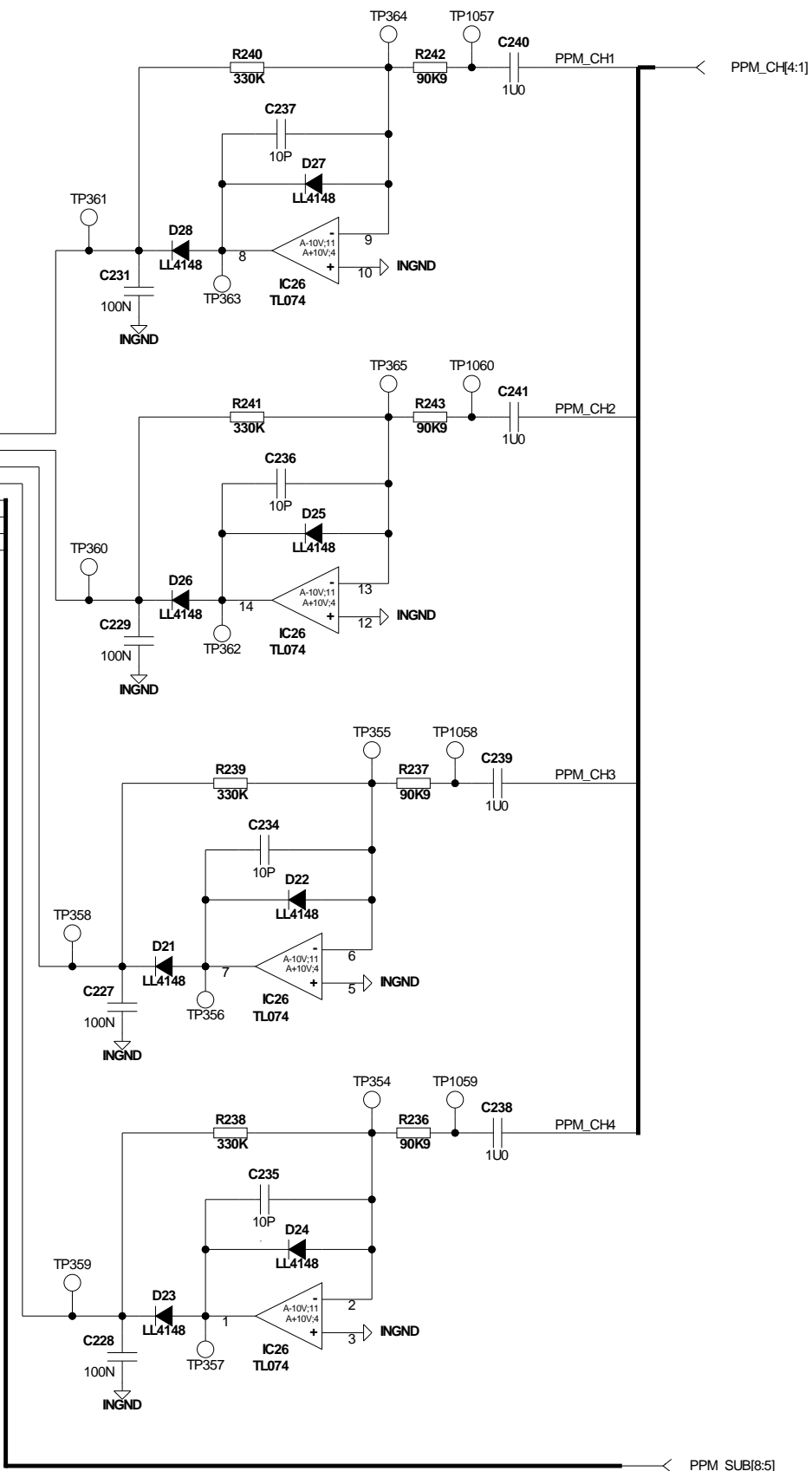
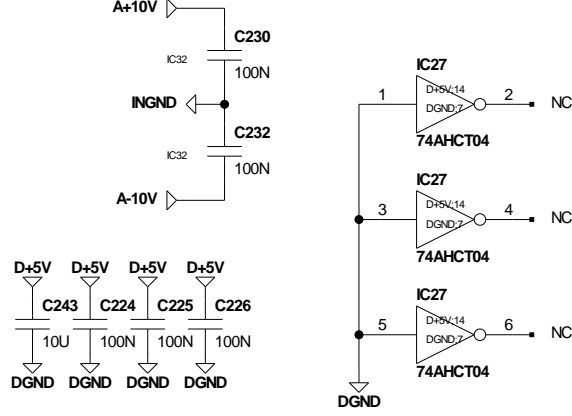
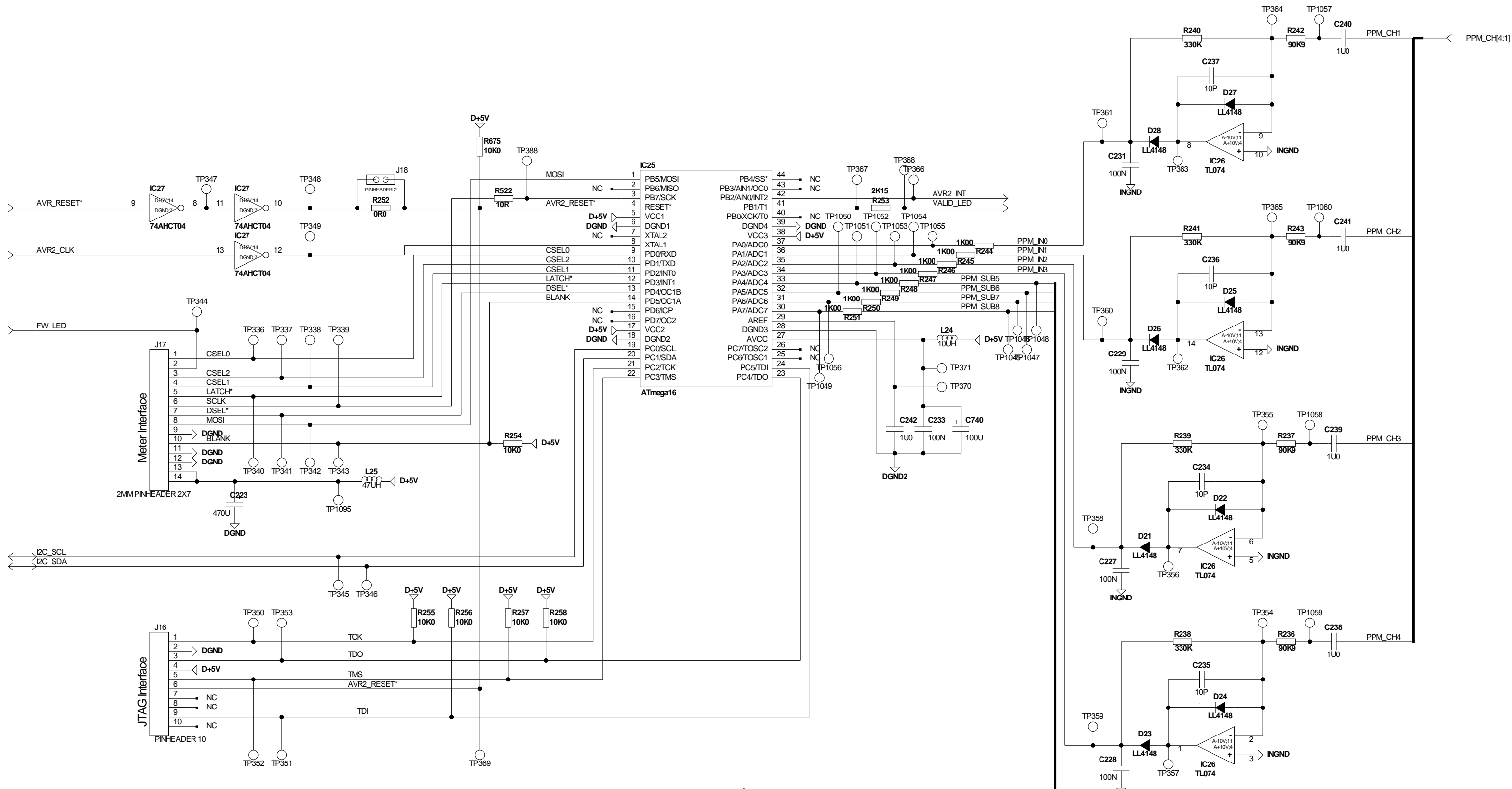

TC Electronic A/S		Designer MFALHOICGF
Title EIO2	Module title METER CONTROLLER	
Number P19321	Revision CAE	Previous page 10
Date 4-15-2008_9:28	Filename METER_CTRL	Page / of 11 / 20

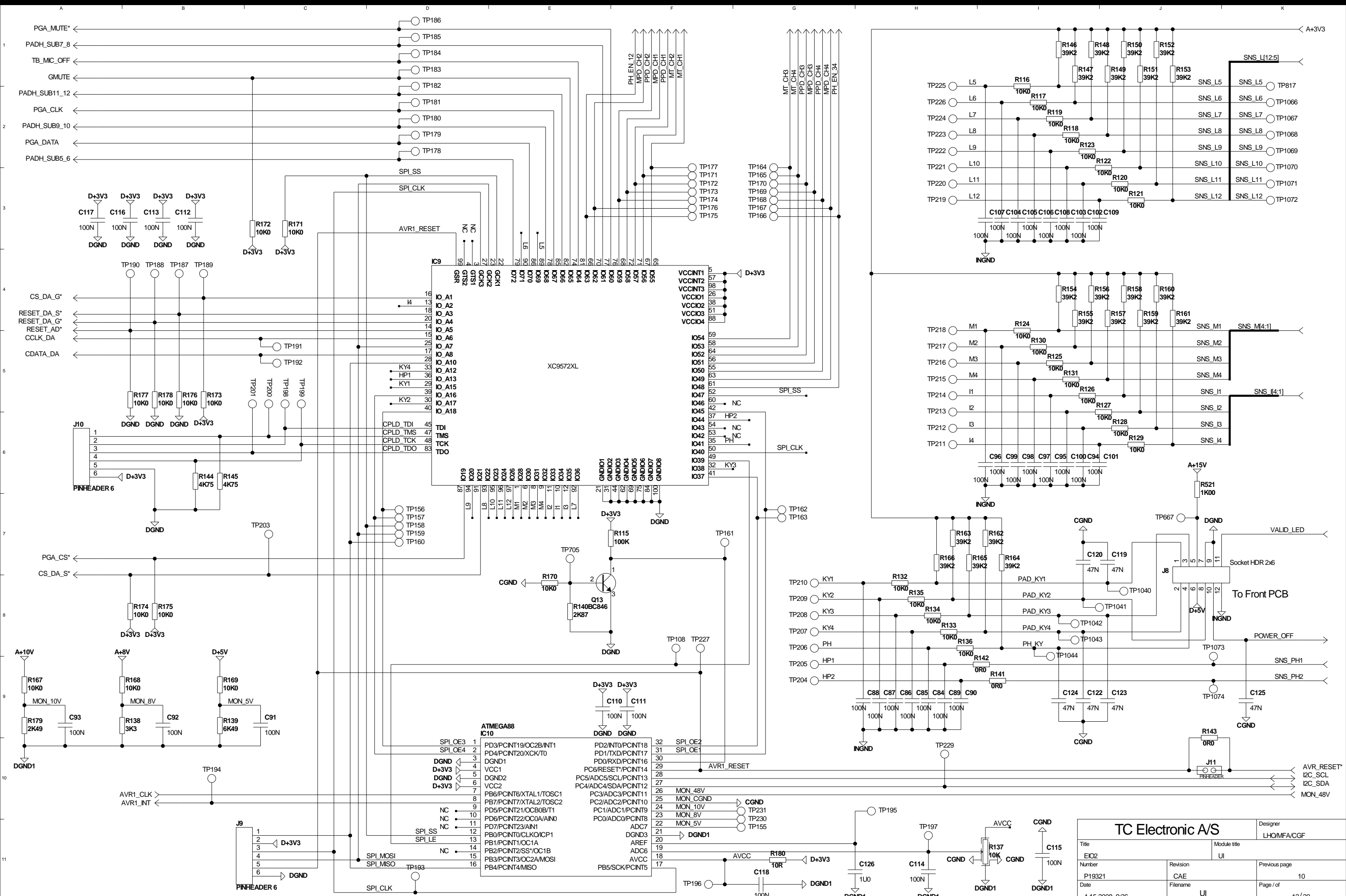

Note
 INA163 change to THAT?? = 370mW save. Will be changed when stock of INA163 is used

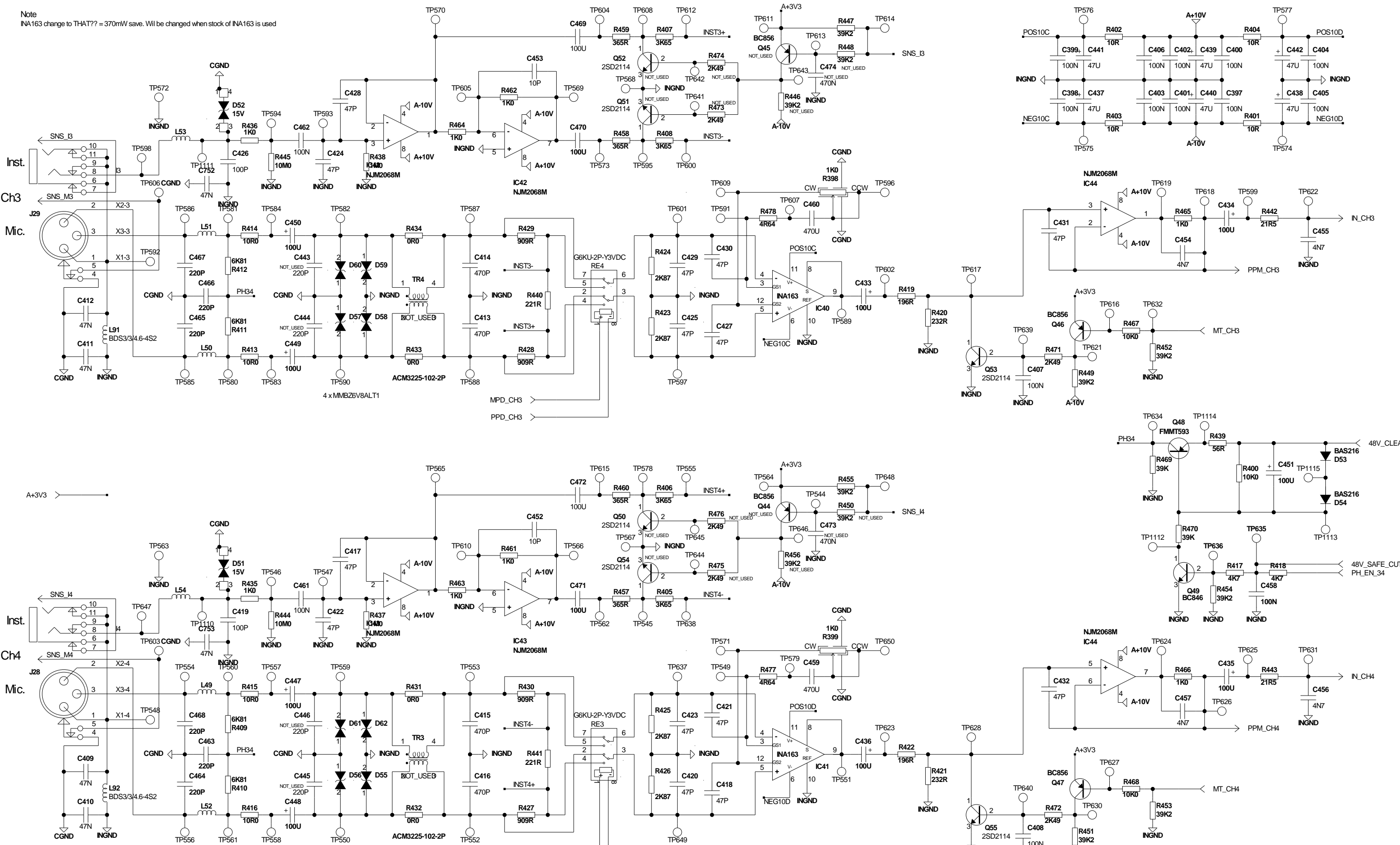

TC Electronic A/S		Designer	MFA/LHO/CGF
Title	Module title		
EIO2	MIC INSTR CH 3-4		
Number	Revision	Previous page	
P19321	CAE	10	
Date	Filenam	Page / of	
4-15-2008_9:34	MIC_IN_34	14 / 20	

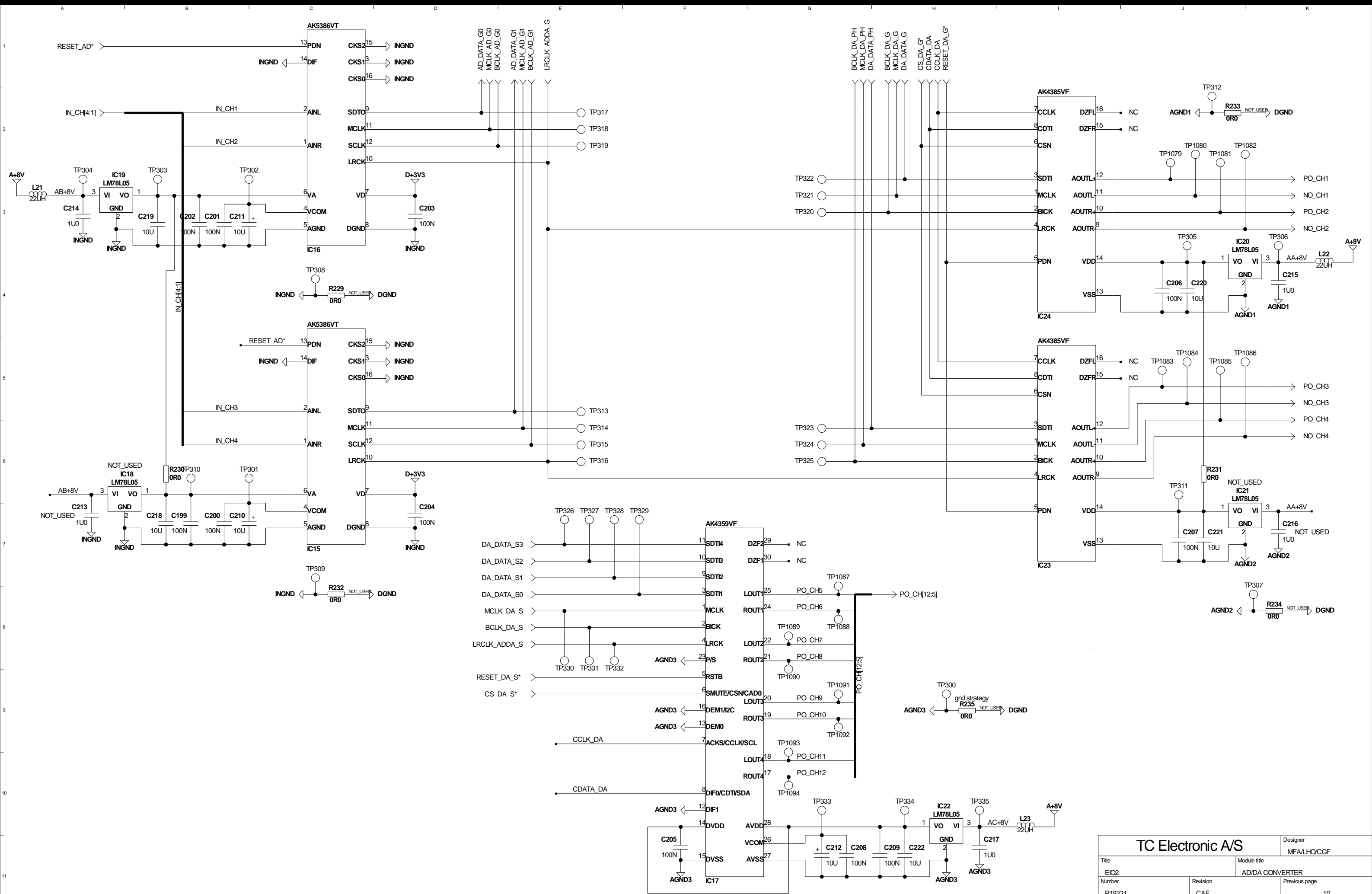

TC Electronic A/S		Designer MFA/LHO/CGF
Title EIO2	Module title AD/DA CONVERTER	
Number P19321	Revision CAE	Previous page 10
Date 4-15-2008_9:28	Filename CONVERTER	Page / of 15 / 20

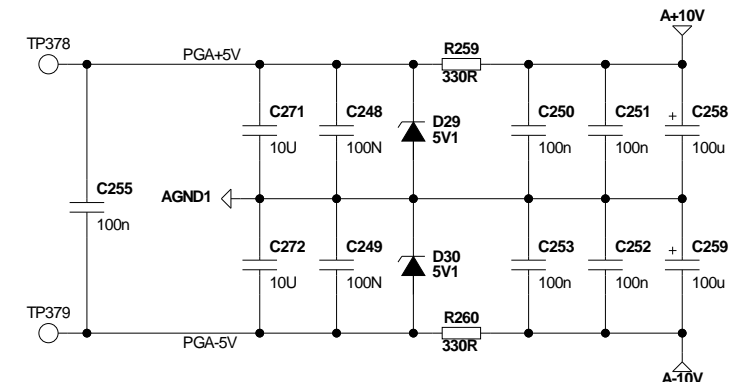
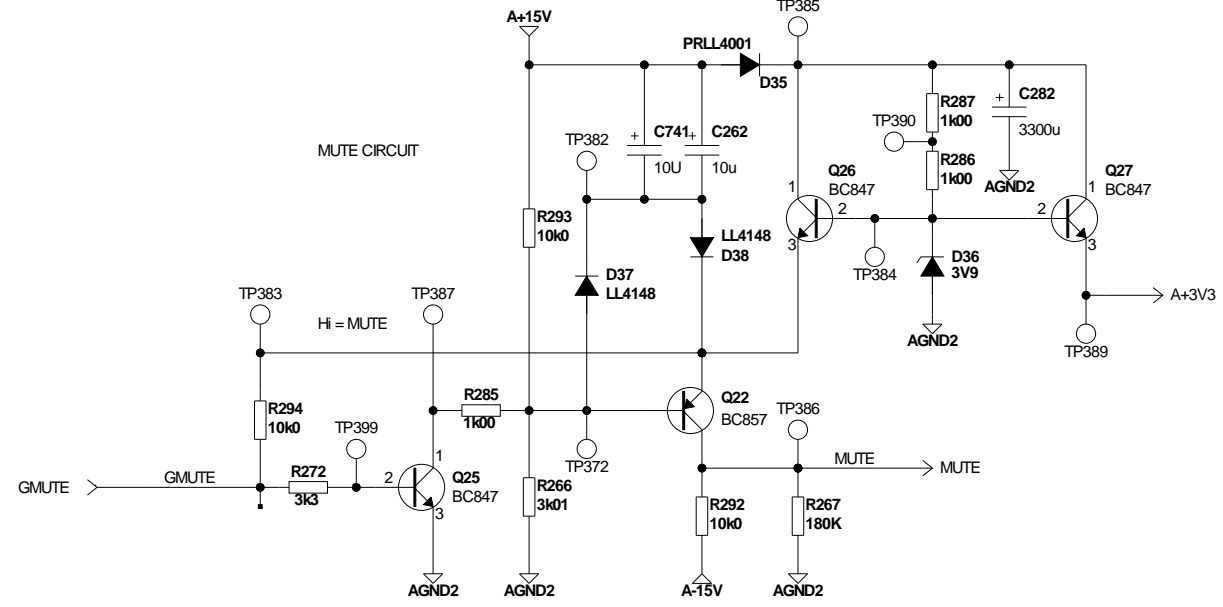
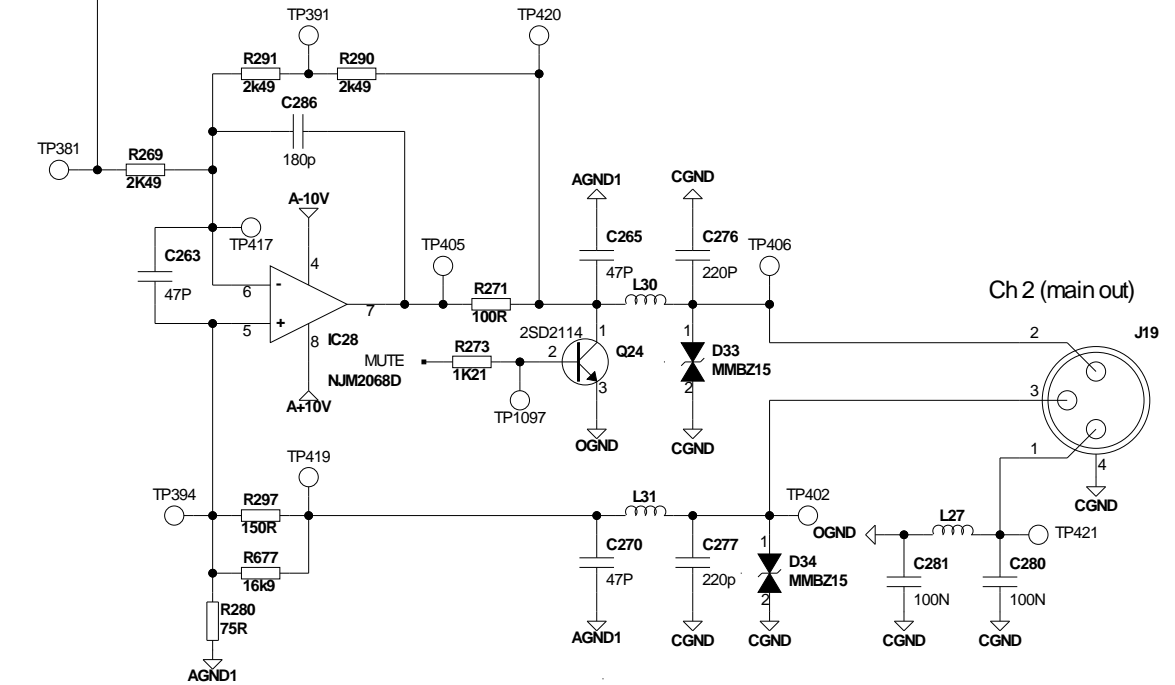
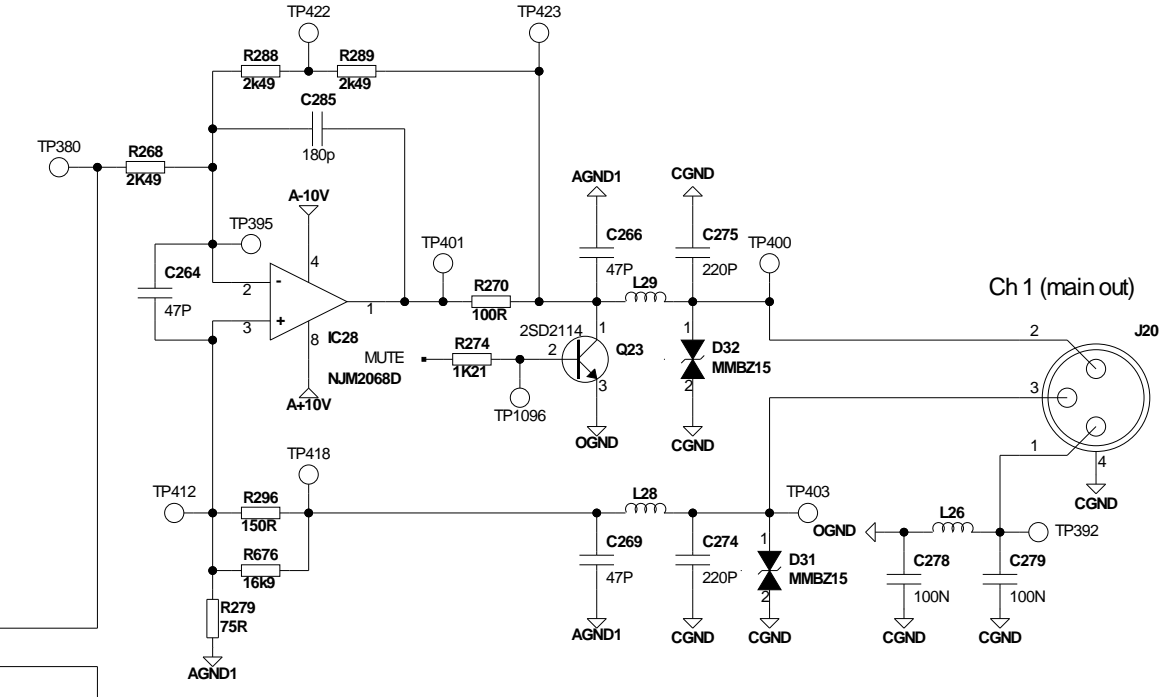
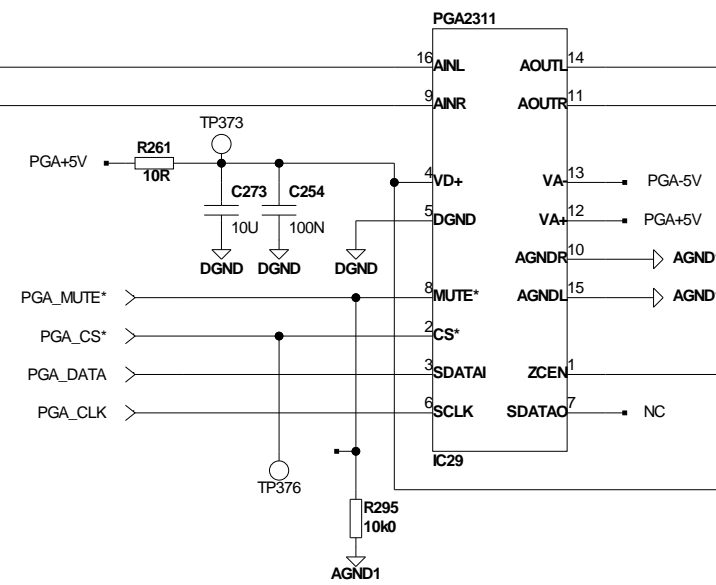
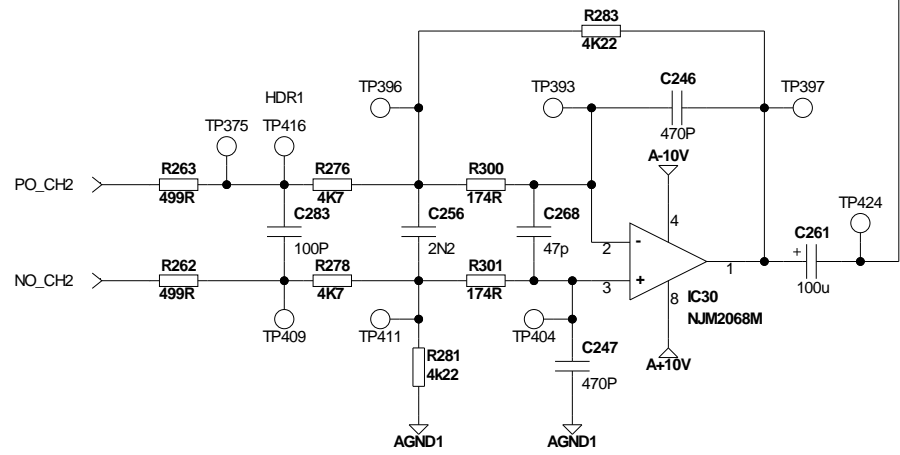
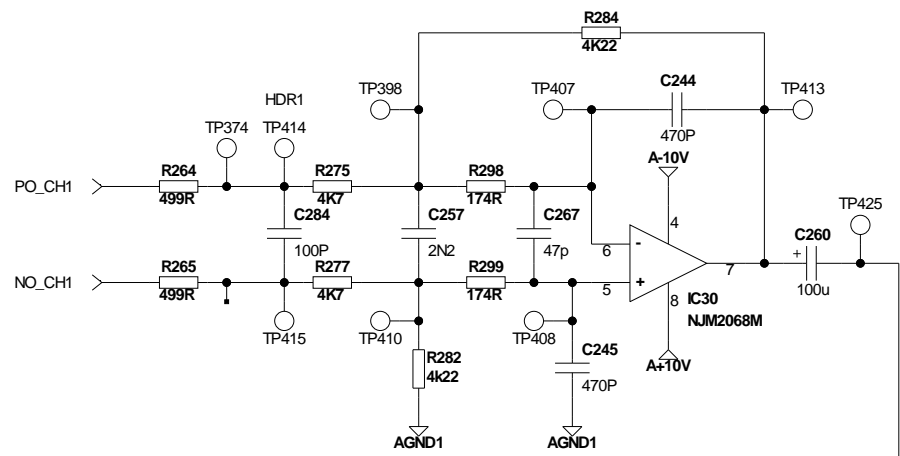

TC Electronic A/S		Designer	MFA/LHO/CGF
Title	EIO2	Module title	MAIN OUTPUT
Number	P19321	Revision	CAE
Date	4-15-2008_9:28	Filename	MAIN_OUT
		Previous page	10
		Page / of	16 / 20

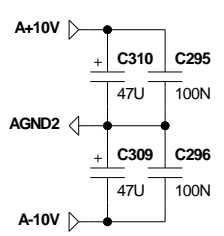
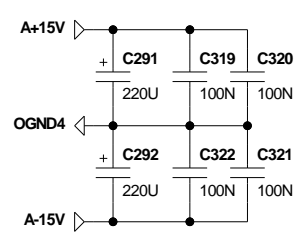
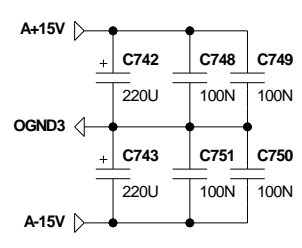
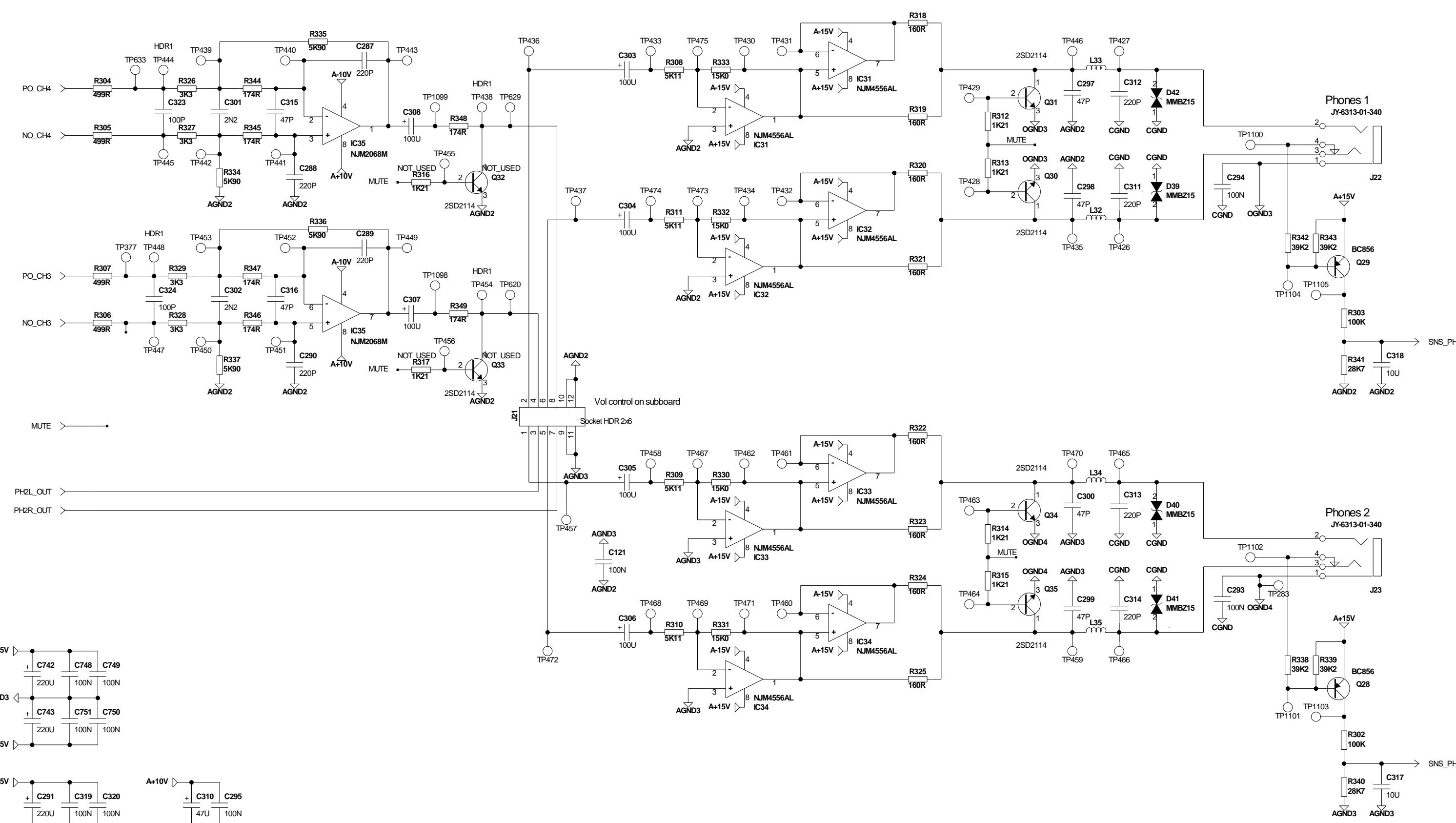

TC Electronic A/S		Designer MFA
Title EIQ2	Module title PHONES OUTPUT	
Number P19321	Revision CAE	Previous page 10
Date 4-15-2008_9:28	Filename PHONES_OUT	Page / of 17 / 20

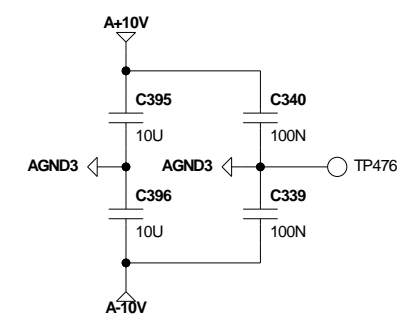
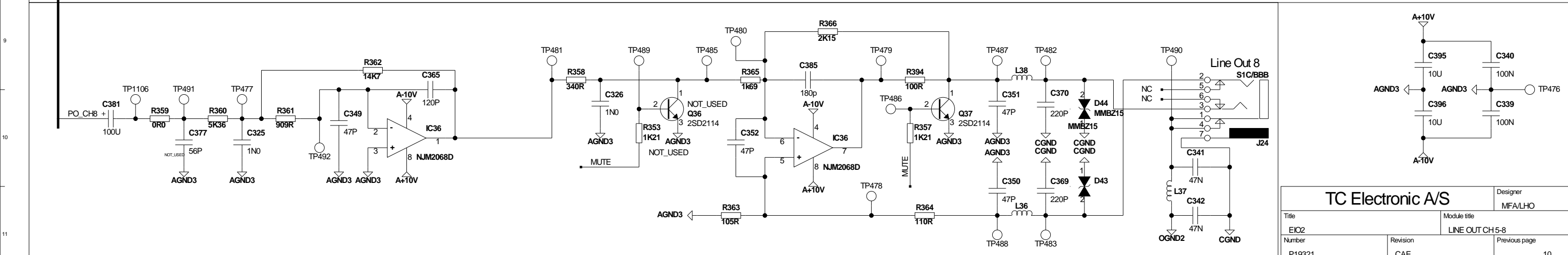
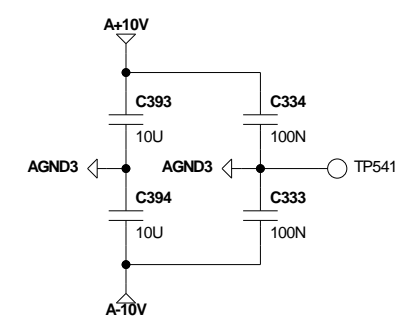
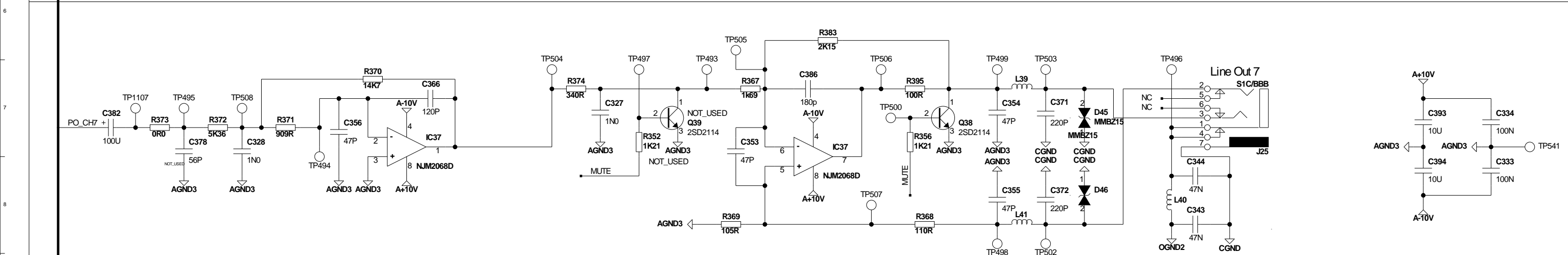
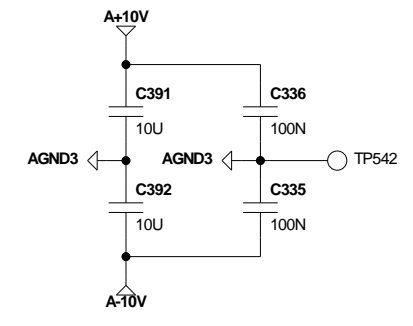
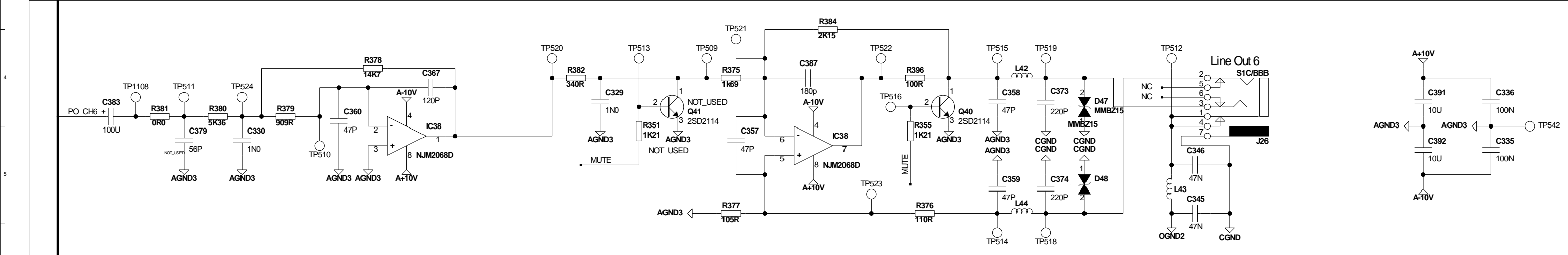
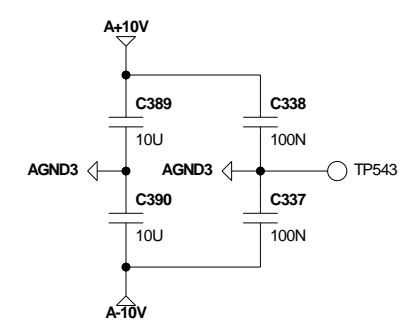
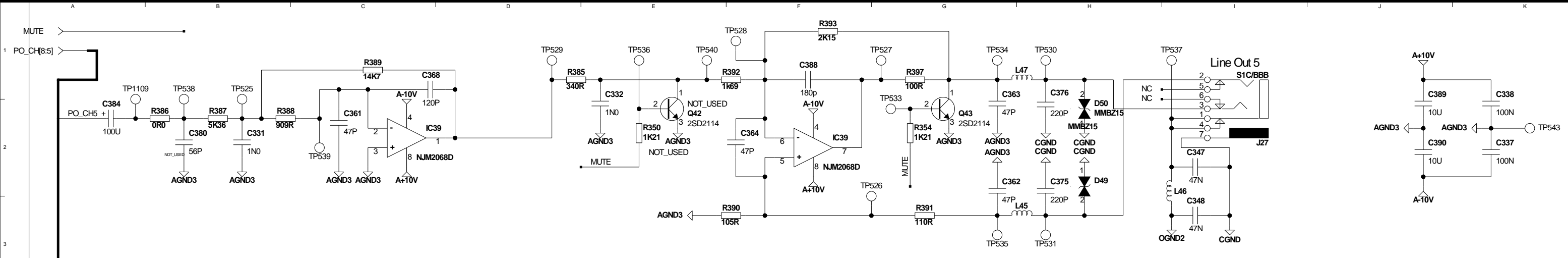

TC Electronic A/S		Designer MFA/LHO
Title EIO2	Module title LINE OUT CH 5-8	
Number P19321	Revision CAE	Previous page 10
Date 4-15-2008_9:33	Filename LINE_OUT	Page / of 18 / 20

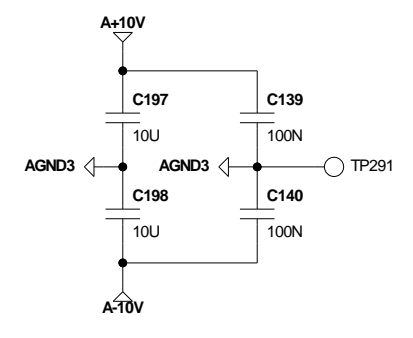
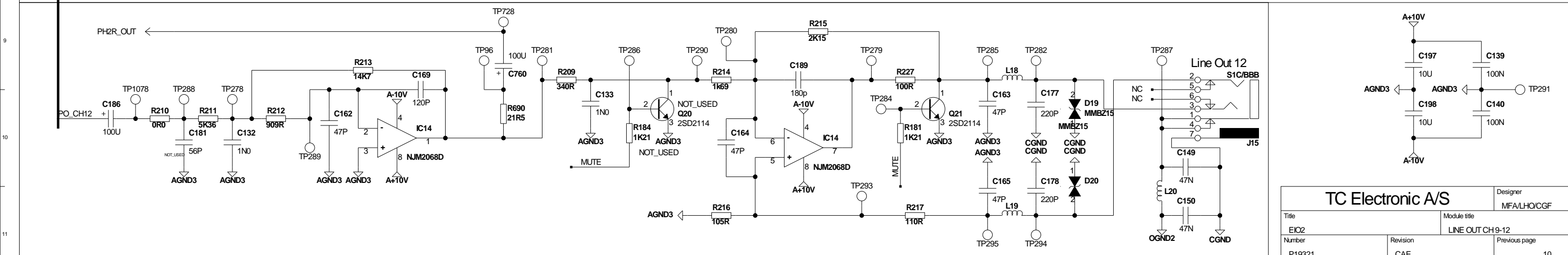
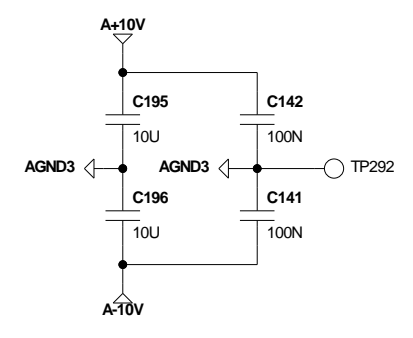
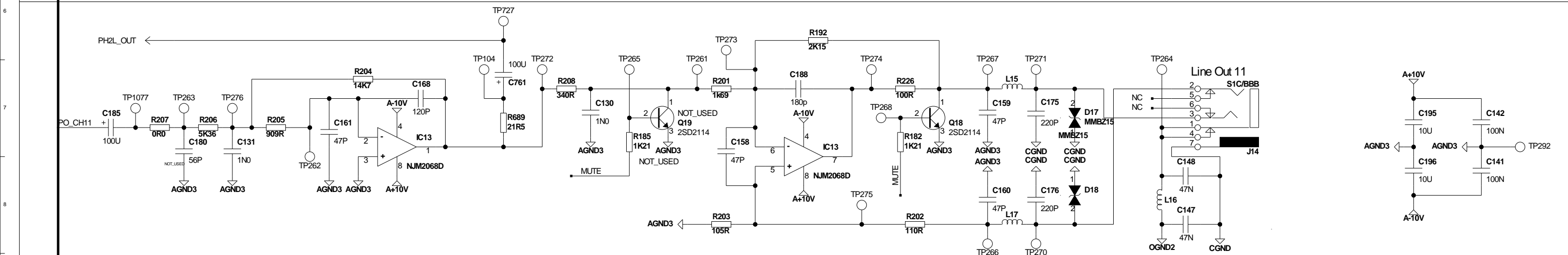
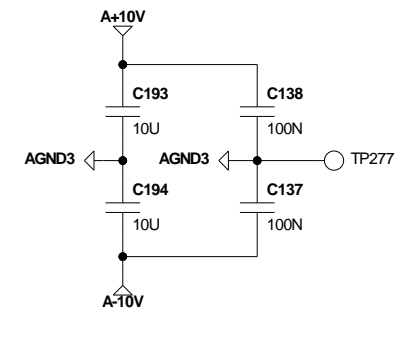
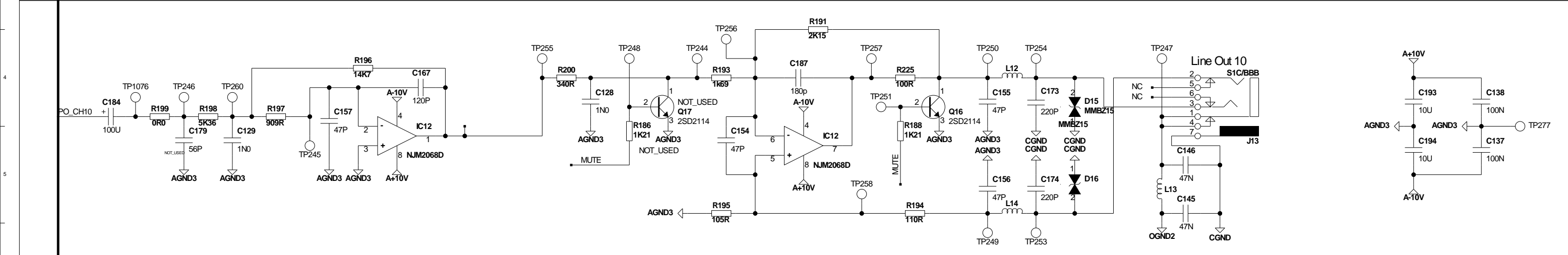
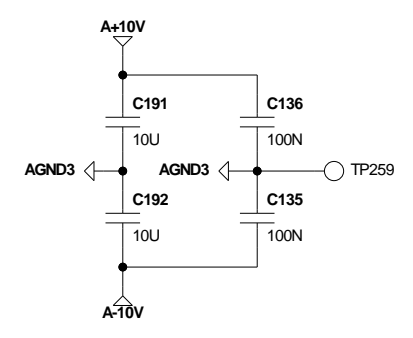
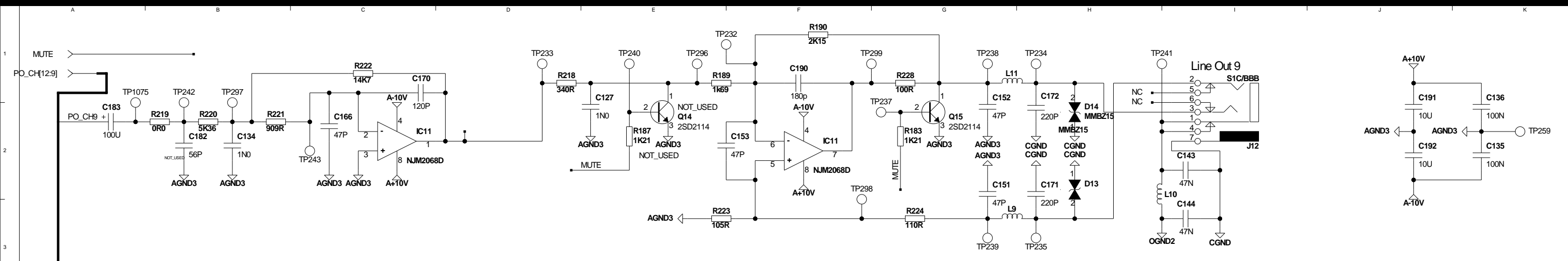

TC Electronic A/S		Designer
		MFA/LHO/CGF
Title	Module title	
EI02	LINE OUT CH 9-12	
Number	Revision	Previous page
P19321	CAE	10
Date	Filename	Page / of
4-15-2008_9:27	LINE_OUT_9_12	19 / 20

SMP5 - CONNECTORS

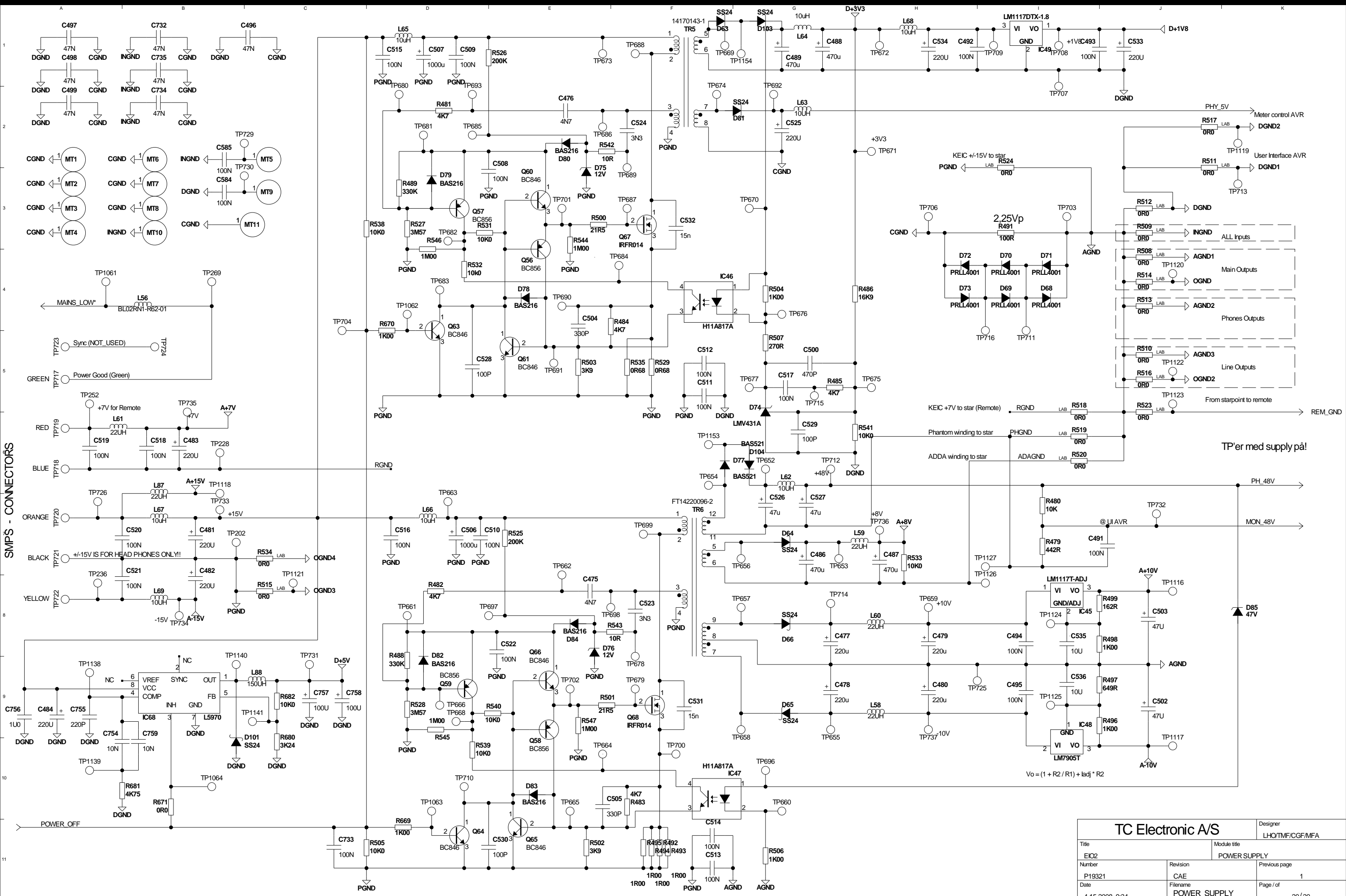

TC Electronic A/S		Designer	LHO/TMF/CGF/MFA
Title	EIO2	Module title	POWER SUPPLY
Number	P19321	Revision	CAE
Date	4-15-2008_9:34	Filename	POWER_SUPPLY
		Previous page	1
		Page / of	20 / 20