

EIO4 MAINBOARD

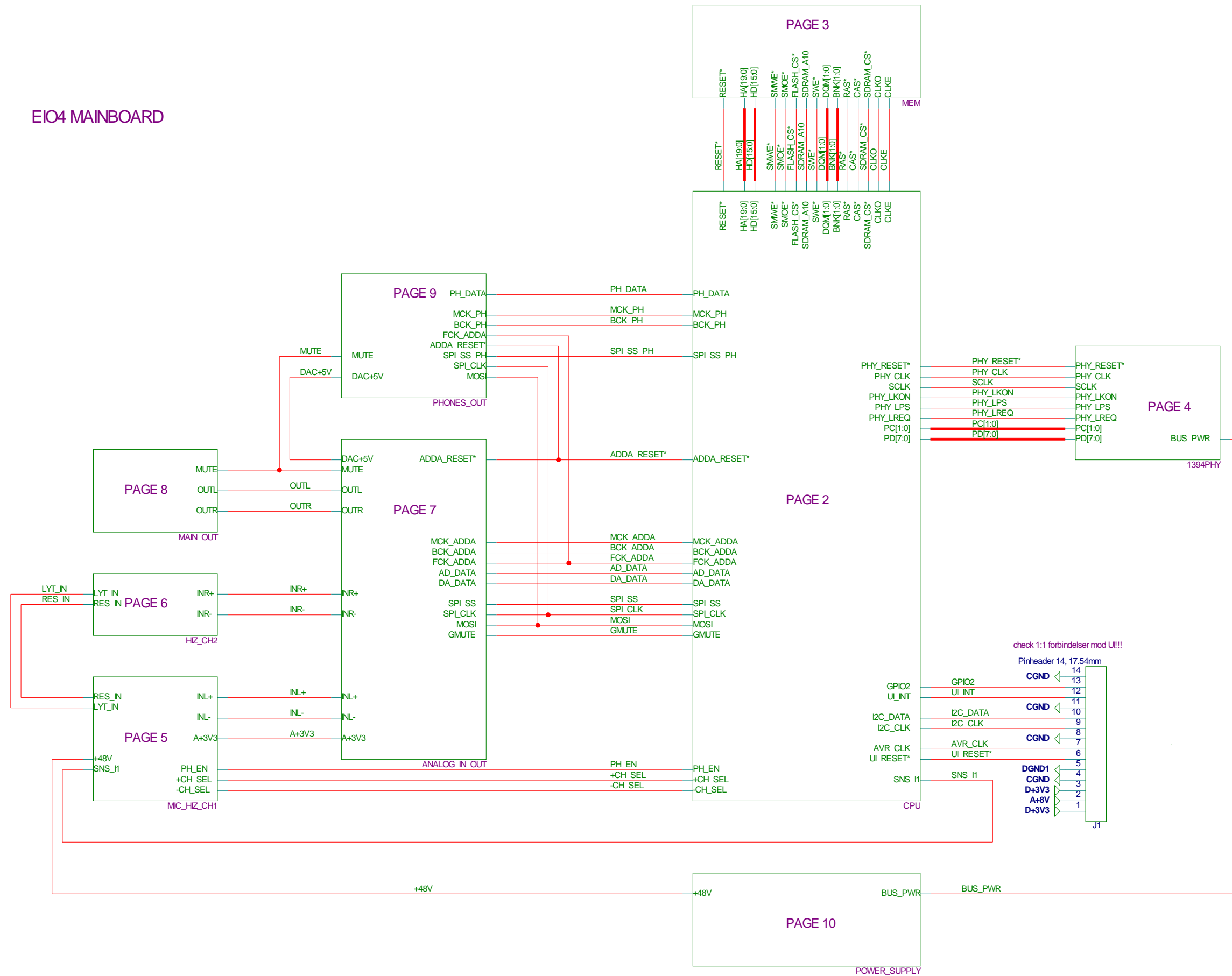

check 1:1 forbindelser mod UI!!!

M1
P19341-C

TC Electronic A/S		Designer
EIO4		MFA/HO/CGF
Number	Revision	Previous page
P19341	CAA	NONE
Date	Filename	Page / of
8-15-2008_10:48	P19341-C	1 / 10

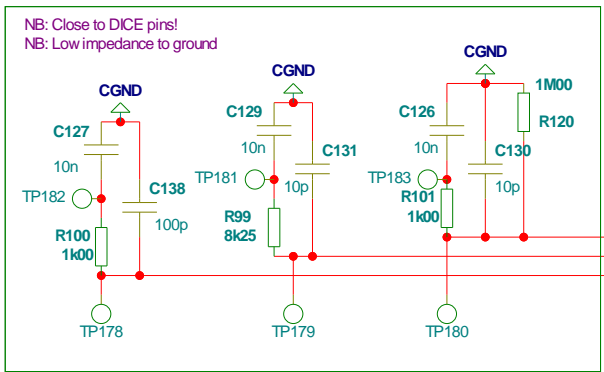
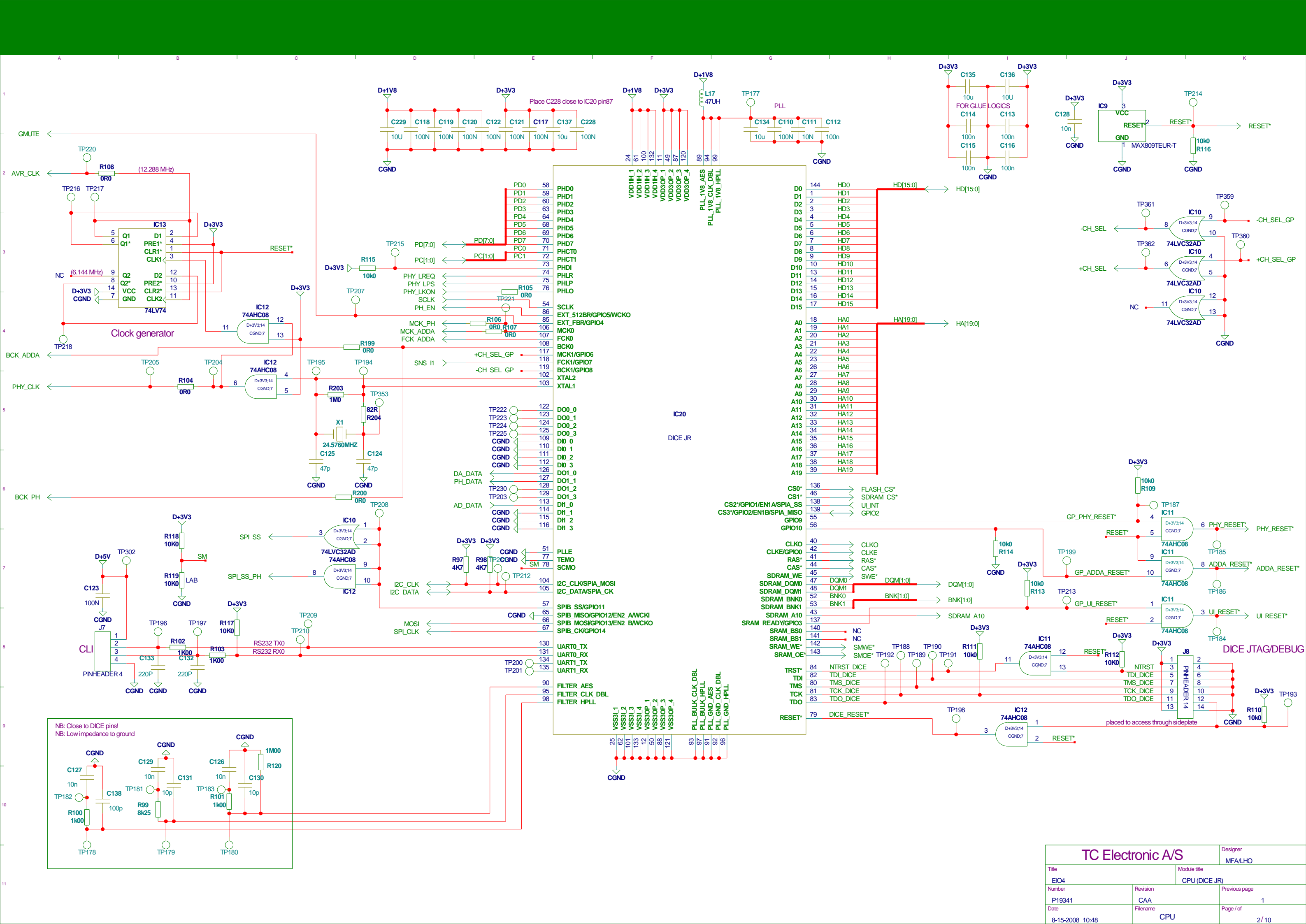

TC Electronic A/S		Designer	MFALHO
Title	Module title		CPU (DICE JR)
Number	Revision	CAA	Previous page
P19341	8-15-2008_10:48	Filename	CPU
Date	8-15-2008_10:48	Page / of	2 / 10

Host Memory

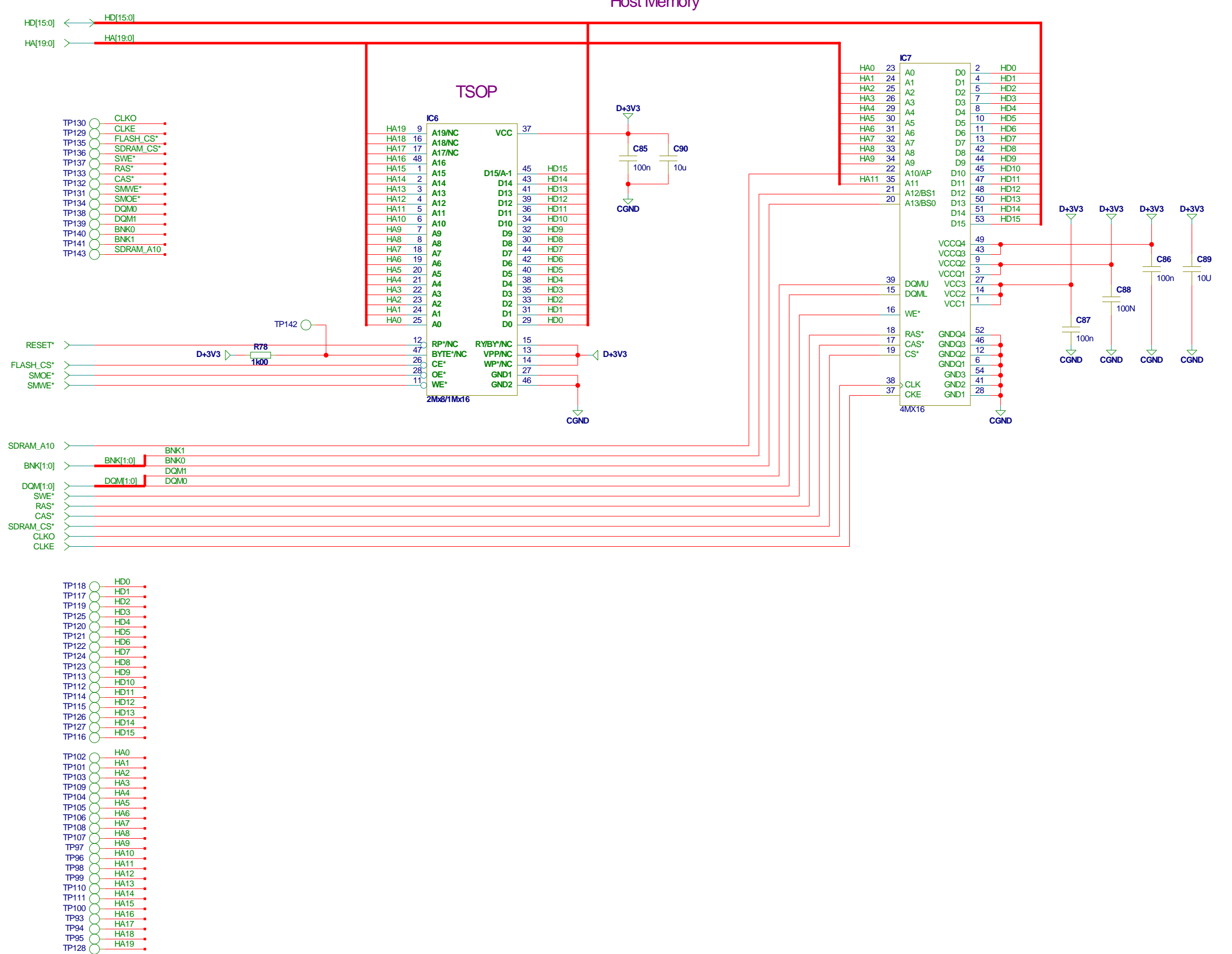

- TP165 ○ PC0
- TP166 ○ PC1
- TP167 ○ PD0
- TP168 ○ PD1
- TP169 ○ PD2
- TP170 ○ PD3
- TP171 ○ PD4
- TP172 ○ PD5
- TP173 ○ PD6
- TP174 ○ PD7

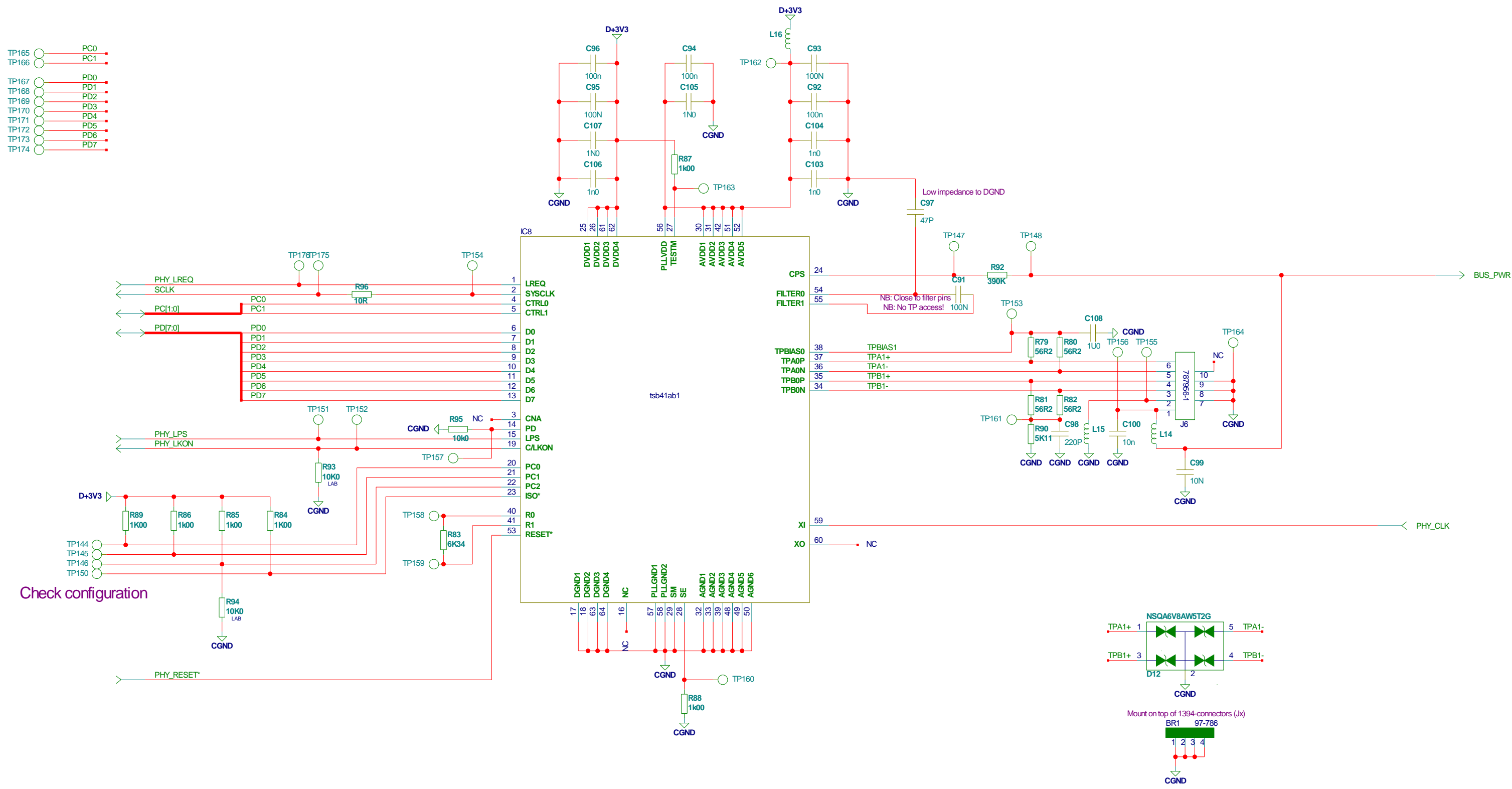

PC0-PC2	DEFAULT POWER CLASS
000	Node does not need power and does not repeat power.
001	Node is self-powered and provides a minimum of 15 W to the bus.
010	Node is self-powered and provides a minimum of 30 W to the bus.
011	Node is self-powered and provides a minimum of 45 W to the bus.
100	Node may be powered from the bus and is using up to 3 W. No additional power is needed to enable the link.
101	Reserved for future standardization.
110	Node is powered from the bus and is using up to 3 W. An additional 3 W is needed to enable the link.
111	Node is powered from the bus and is using up to 3 W. An additional 7 W is needed to enable the link.

TC Electronic A/S		Designer
		LHOMFACGF
Title	Module title	
EIO4	FIREWIRE PHY	
Number	Revision	Previous page
P19341	CAA	1
Date	Filename	Page / of
8-14-2008_15:02	1394PHY	4 / 10

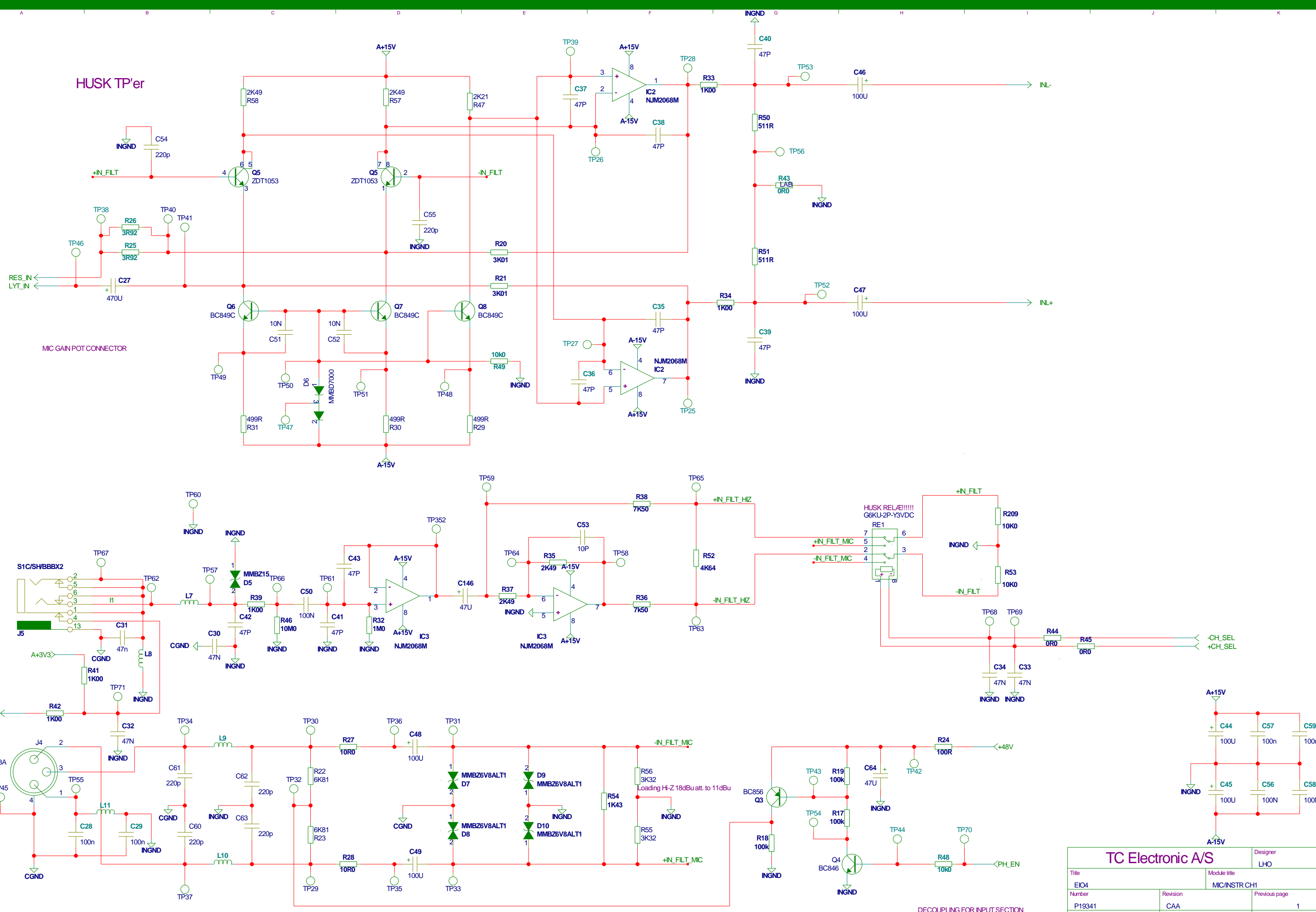

TC Electronic A/S		Designer	LHO
Module title		MIC/INSTR CH1	
Title	EIO4	Revision	CAA
Number	P19341	Filename	MIC_HIZ_CH1
Date	8-14-2008_15:02	Page / of	1 / 10

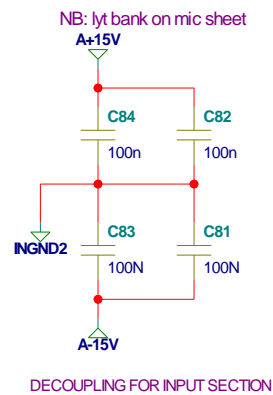
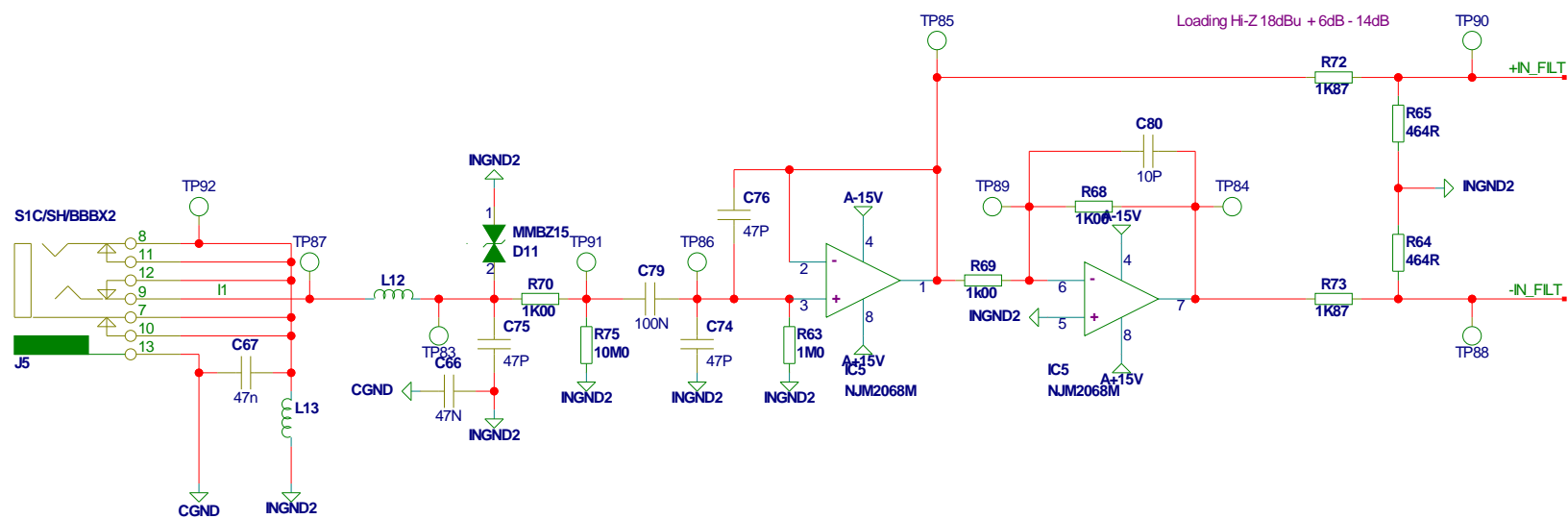
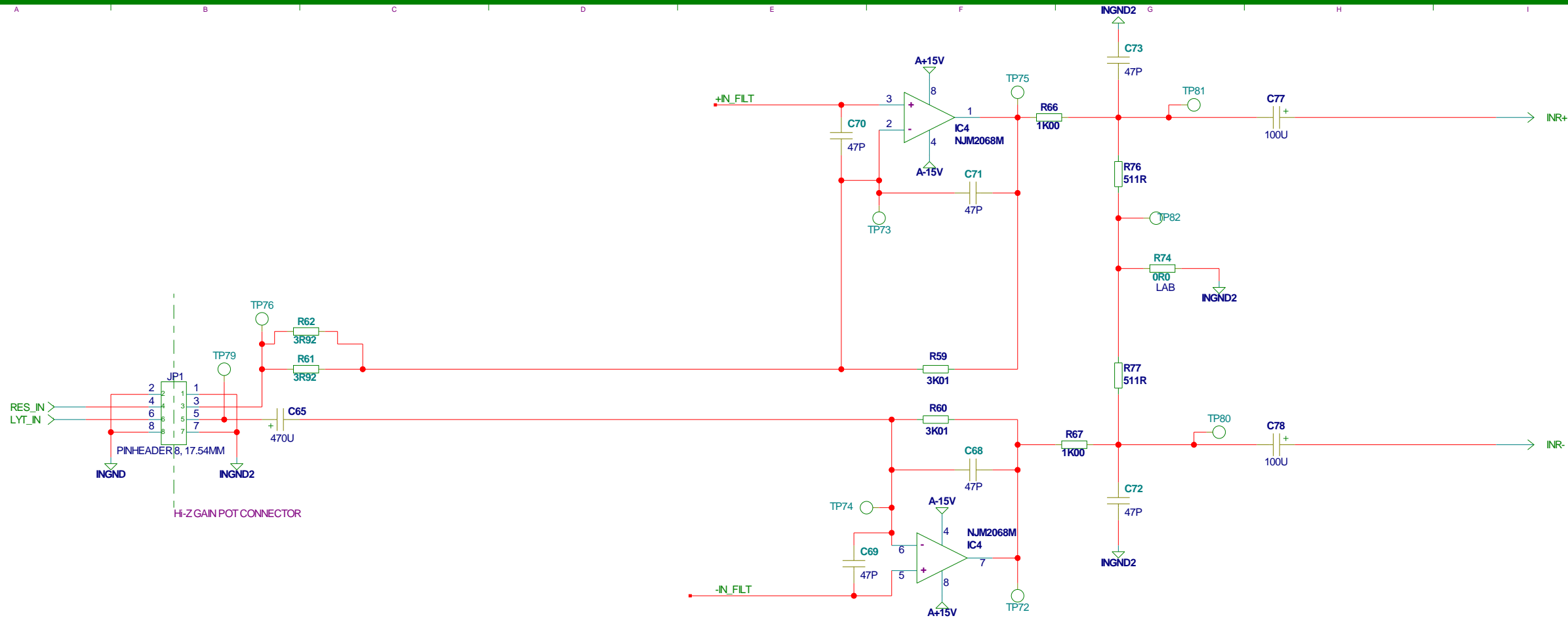

DECOUPLING FOR INPUT SECTION

TC Electronic A/S		Designer
		LHO
Title	Module title	
EIO4	INSTR CH2	
Number	Revision	Previous page
P19341	CAA	1
Date	Filename	Page / of
8-14-2008_15:02	HIZ_CH2	6 / 10

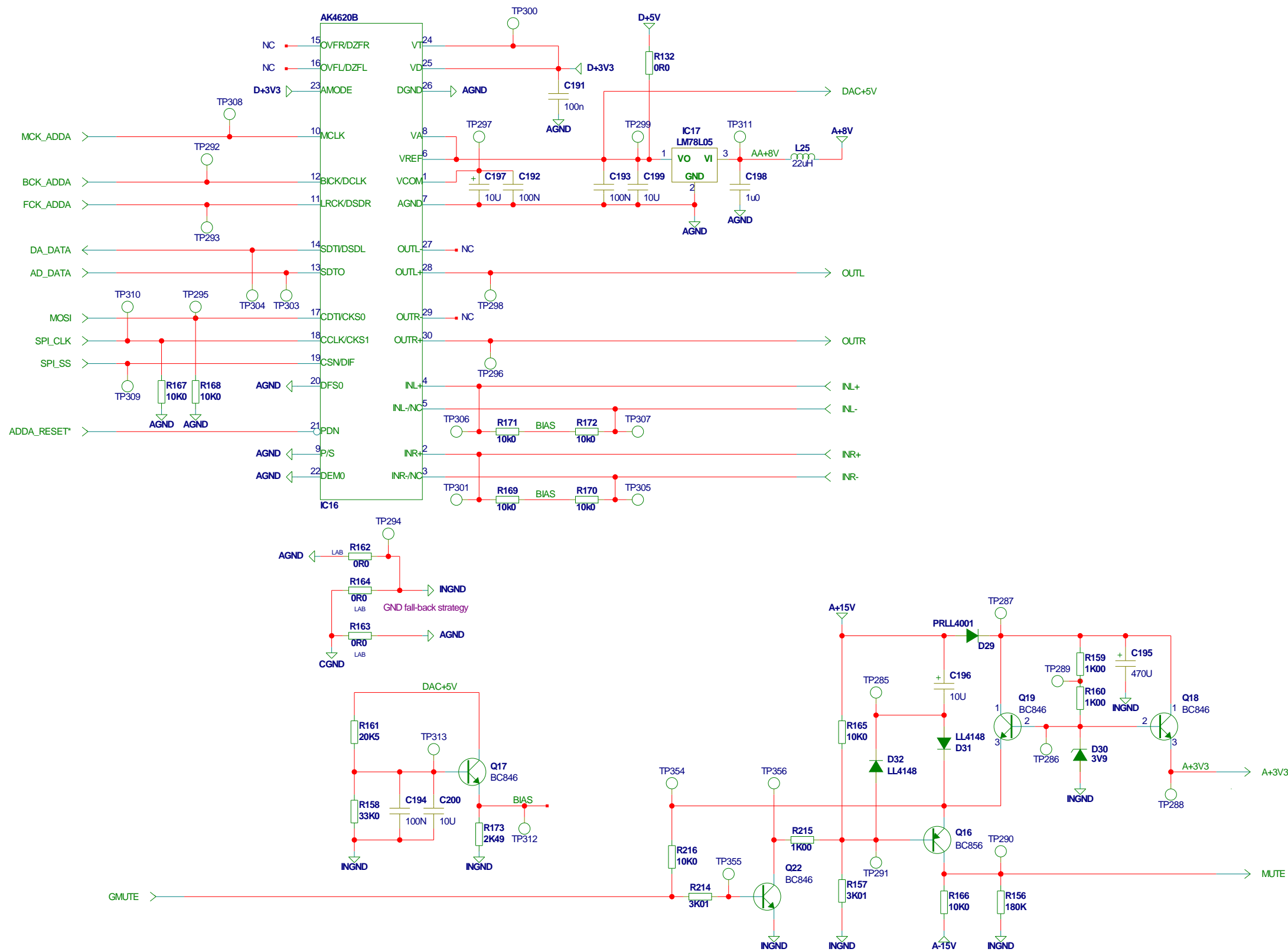

TC Electronic A/S		Designer LHO
Title EIO4	Module title ANALOG IN/OUT	
Number P19341	Revision CAA	Previous page 1
Date 8-14-2008 15:02	Filename ANALOG_IN_OUT	Page / of 7 / 10

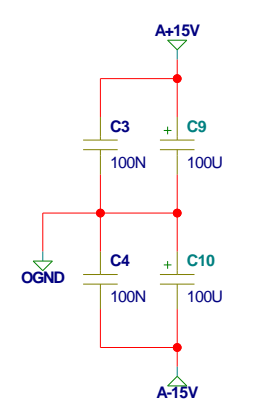
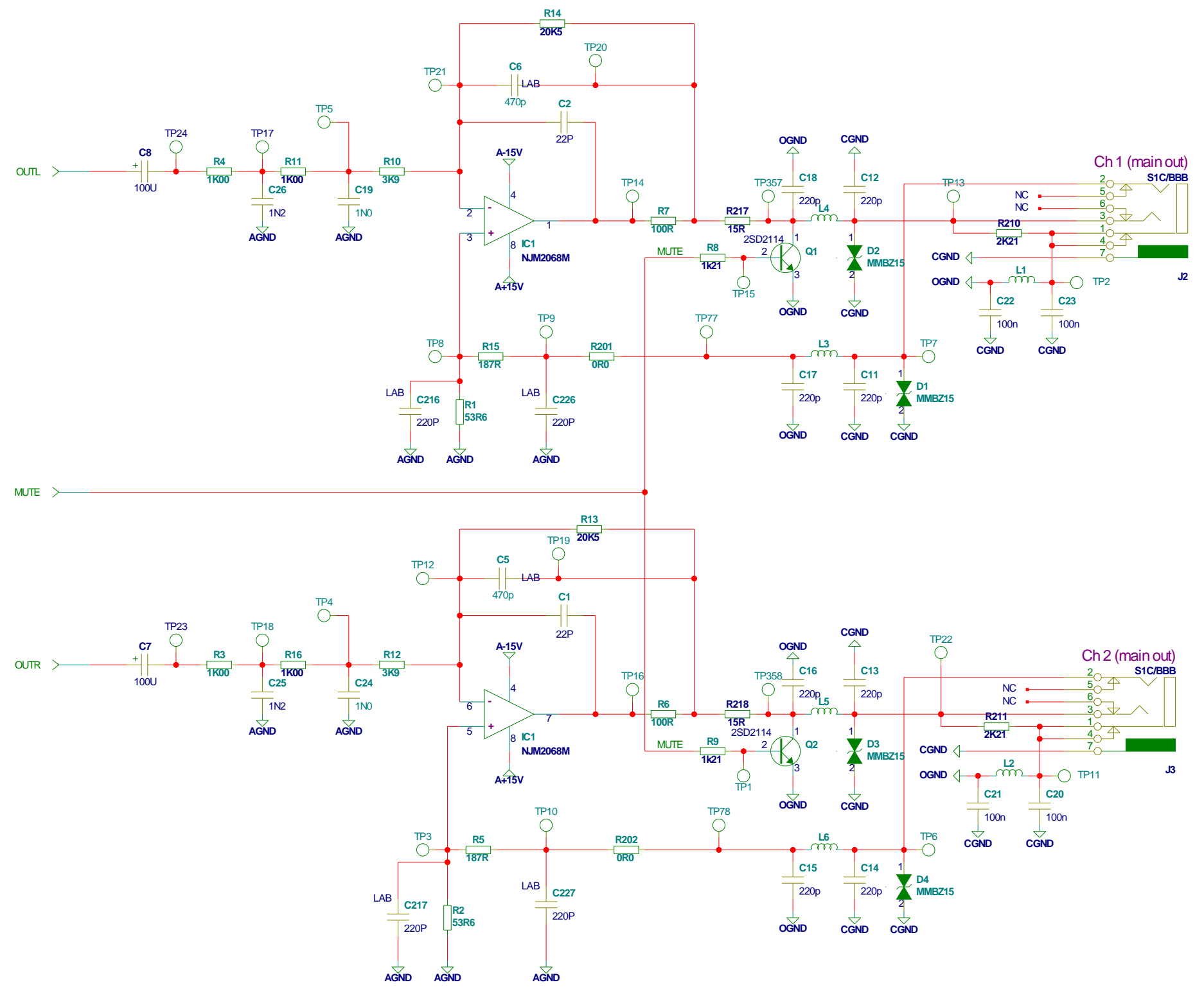

Title		TC Electronic A/S		Designer	
EIO4		Module title		LHO	
Number		Revision		Previous page	
P19341		CAA		1	
Date		Filename		Page / of	
8-14-2008_15:02		MAIN_OUT		8 / 10	

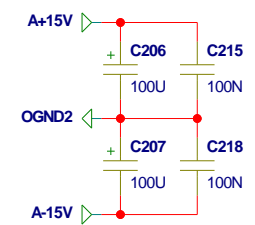
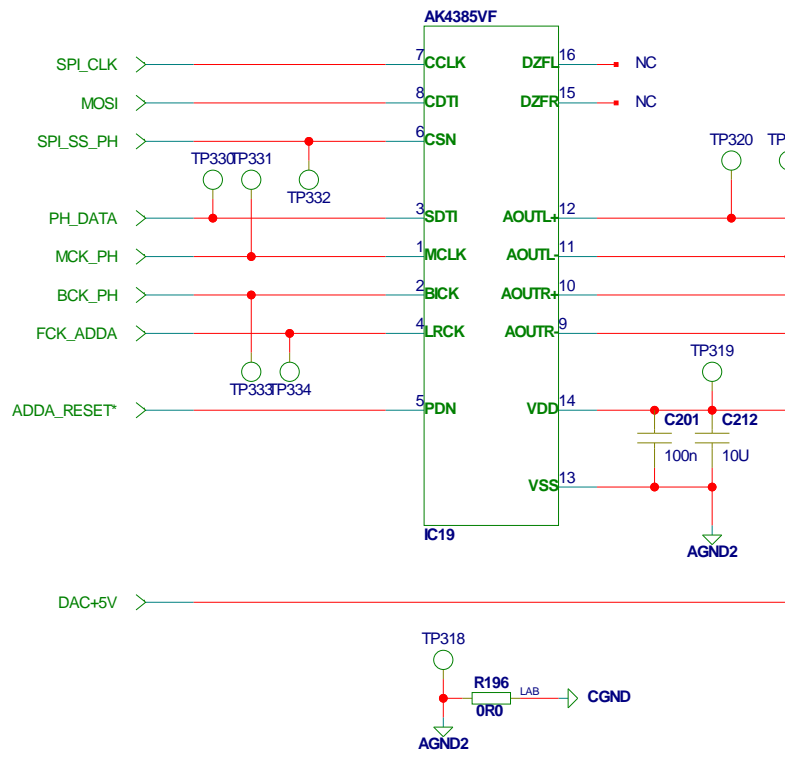
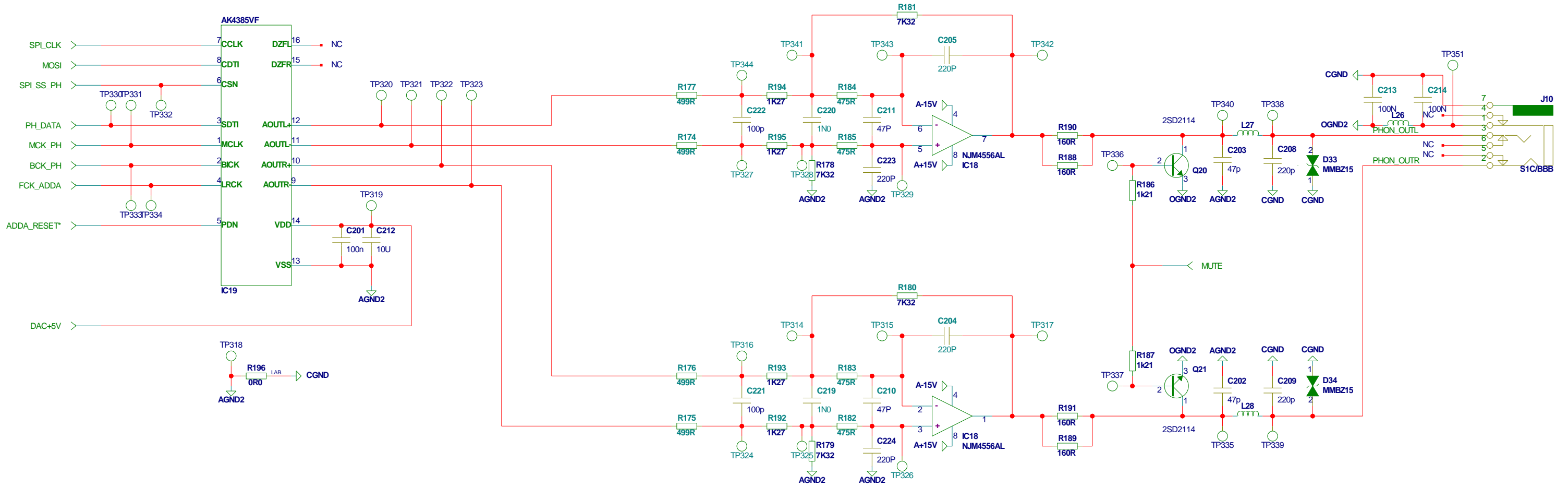

TC Electronic A/S		Designer LHO
Title EIO4	Module title PHONES OUTPUT	
Number P19341	Revision CAA	Previous page 1
Date 8-14-2008_15:02	Filename PHONES_OUT	Page / of 9 / 10

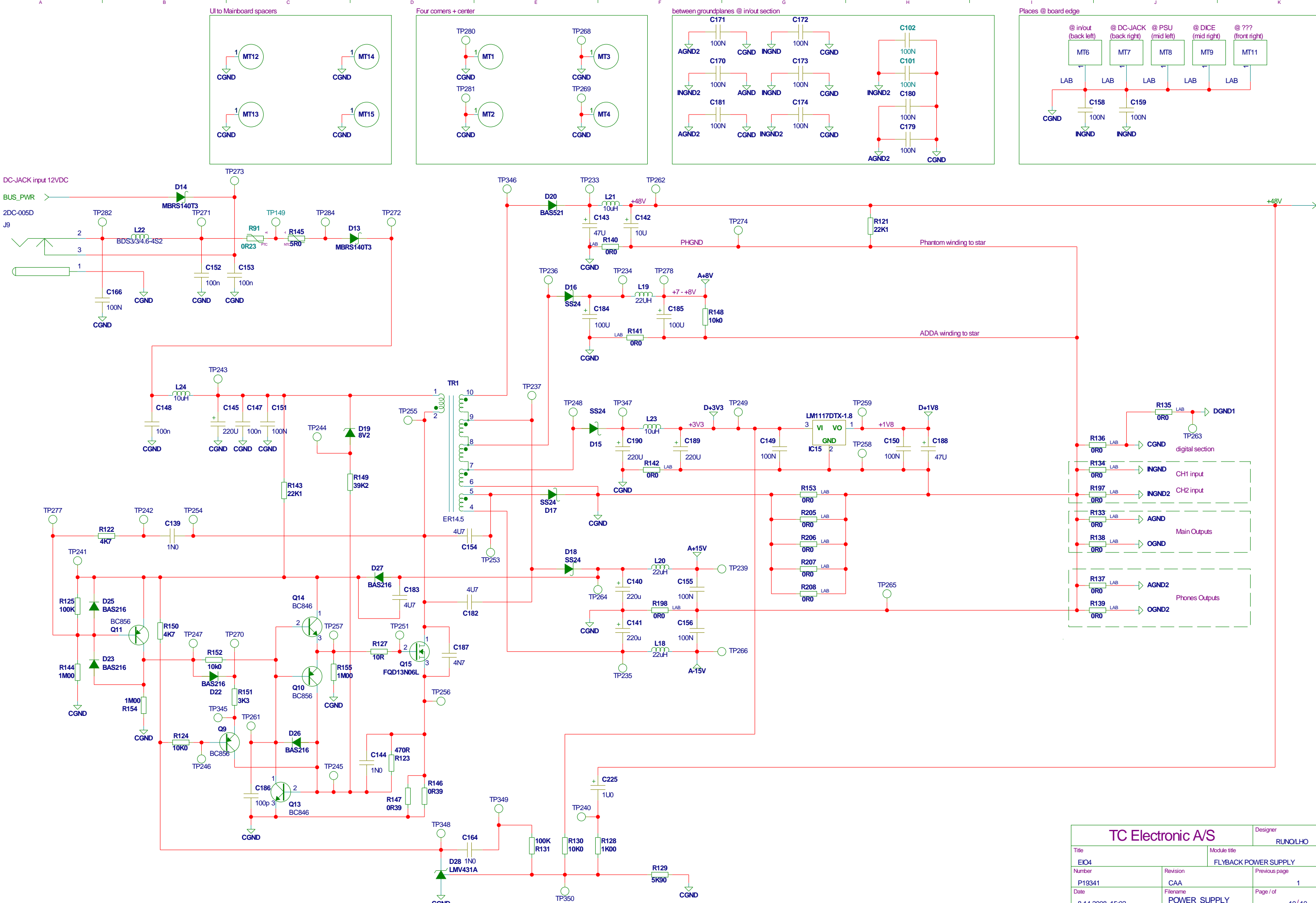

TC Electronic A/S		Designer
		RUNOLHO
Title	Module title	
EIO4	FLYBACK POWER SUPPLY	
Number	Revision	Previous page
P19341	CAA	1
Date	Filename	Page / of
8-14-2008_15:02	POWER_SUPPLY	10 / 10