

# LM2 Front

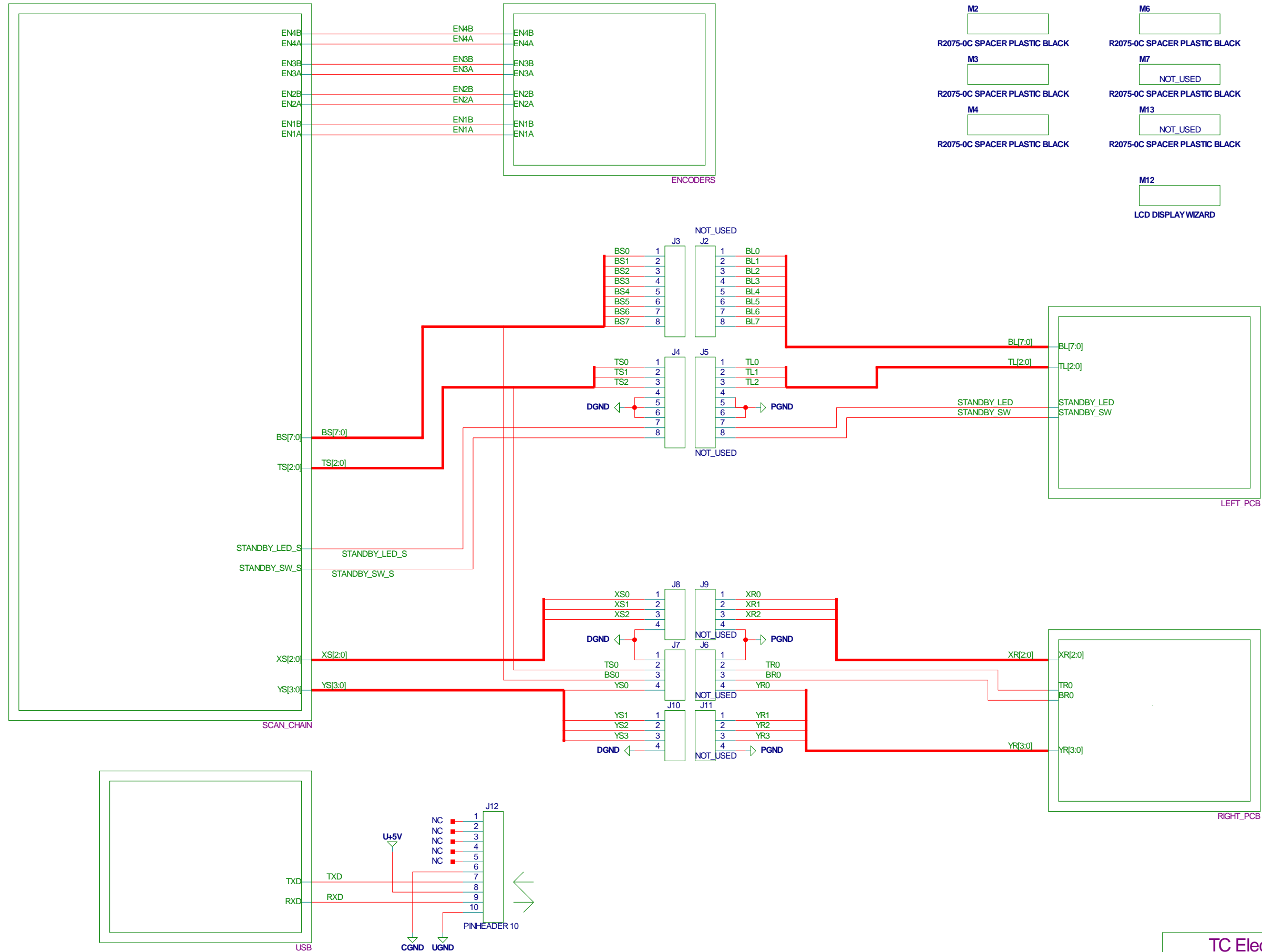

<b>TC Electronic A/S</b>		Designer NIM
Title Viking 12	Module title MAIN	
Number P12512	Revision CAB	Previous page 0
Date 8-20-2010_14:37	Filename P12512-CBA	Page / of 1 / 6

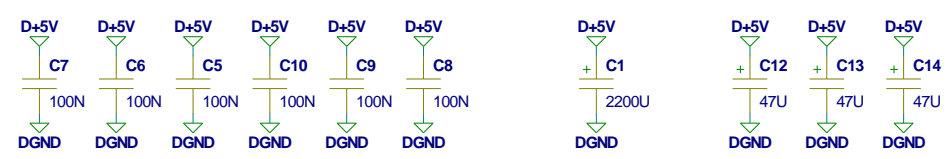
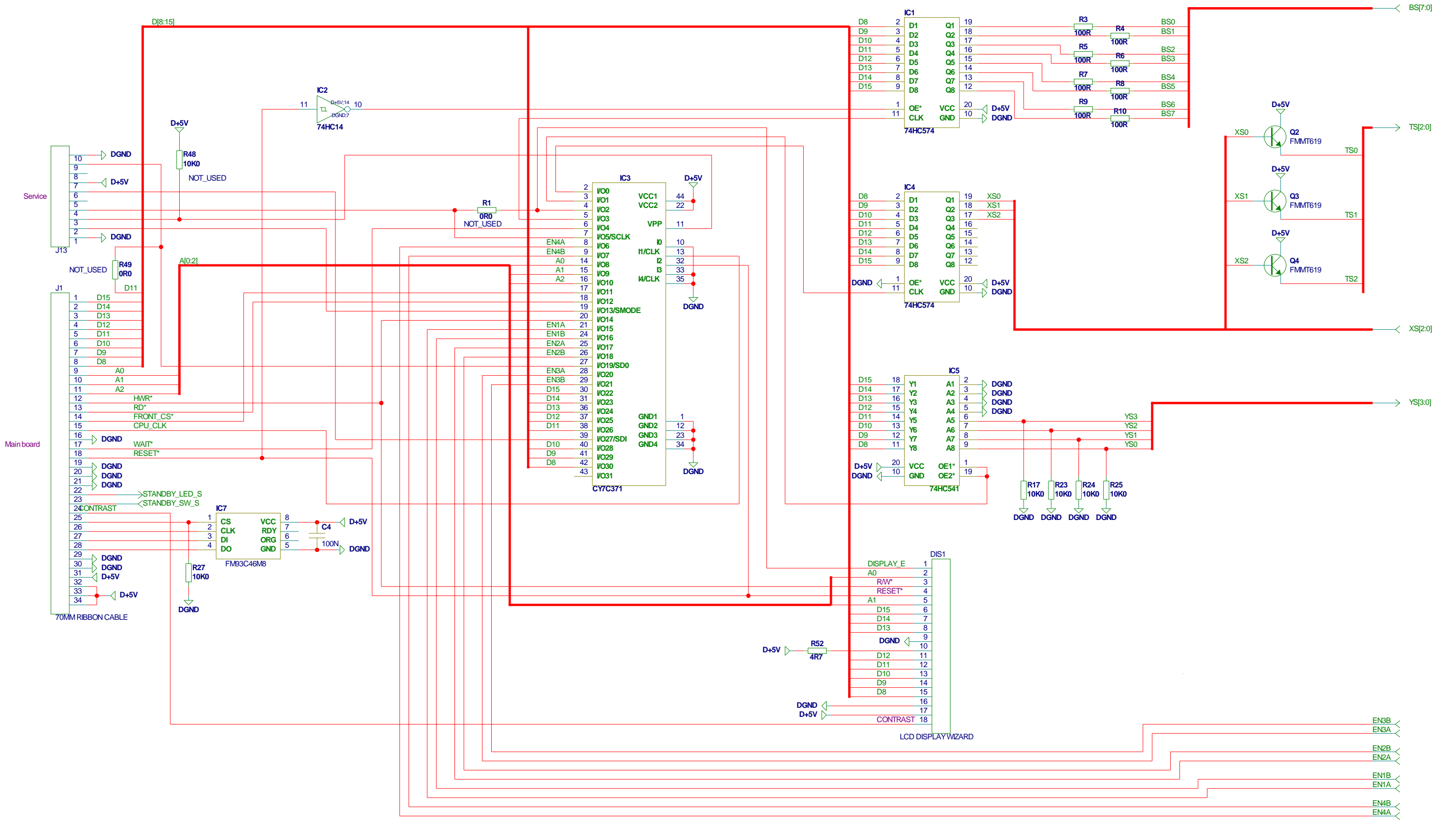

<b>TC Electronic A/S</b>		Designer NIM
Title VIKING 12	Module title SCAN_CHAIN_SECTION	
Number P12512	Revision CAB	Previous page 1
Date 6-15-2010_10:29	Filename SCAN_CHAIN	Page / of 5 / 6

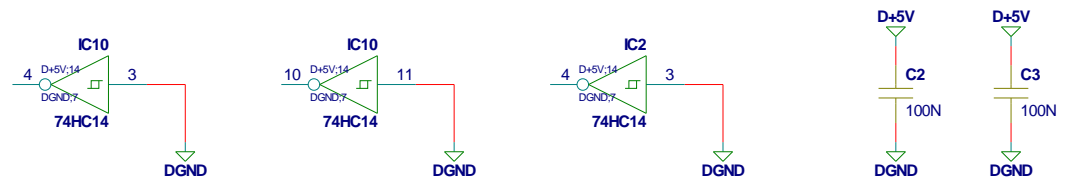
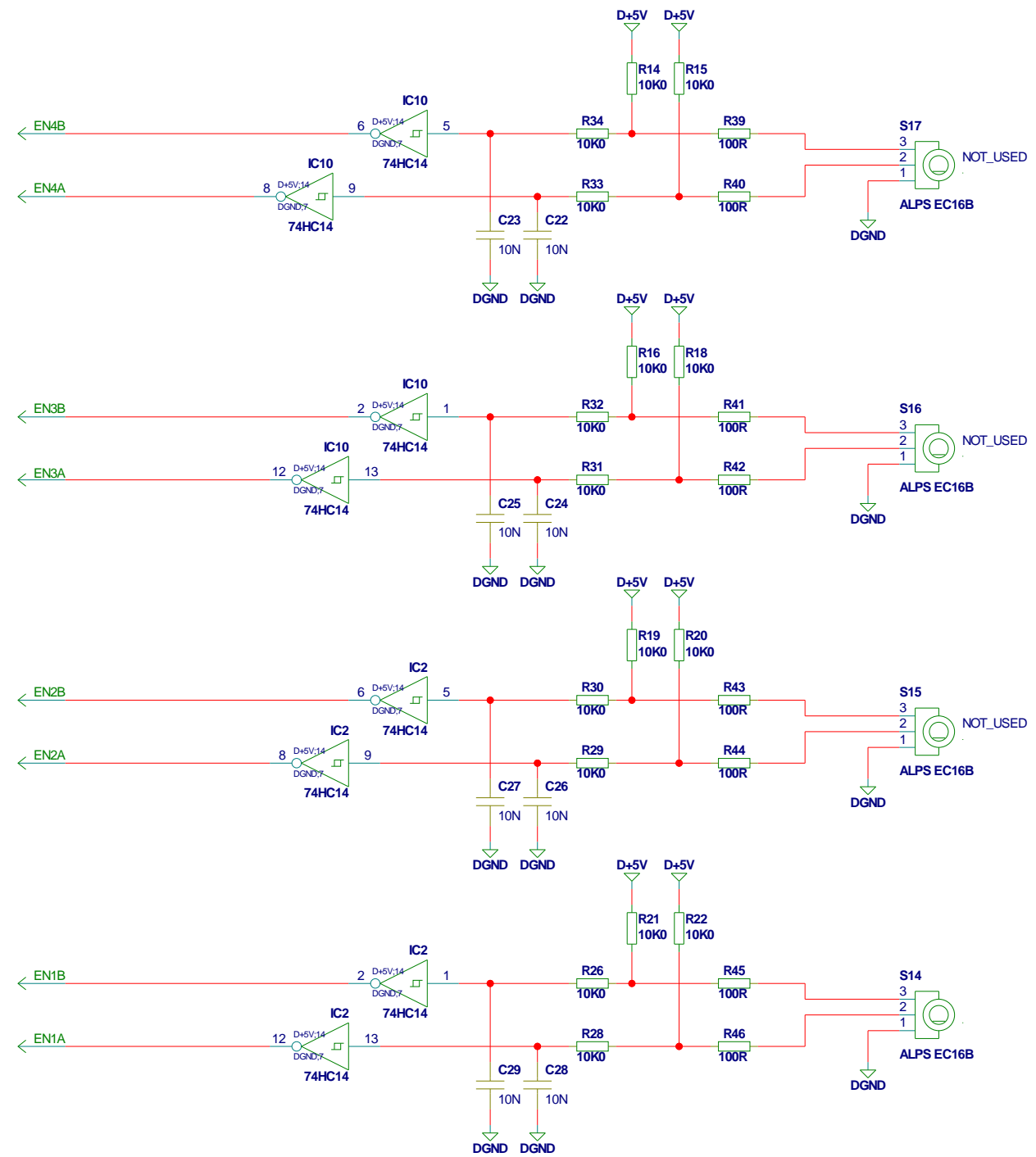

TC Electronic A/S		Designer
Title VIKING 12		NIM
Module title ENCODERS SECTION		
Number P12512	Revision CAB	Previous page 1
Date 6-14-2010_15:03	Filename ENCODERS	Page / of 2 / 6

# LEFT PCB

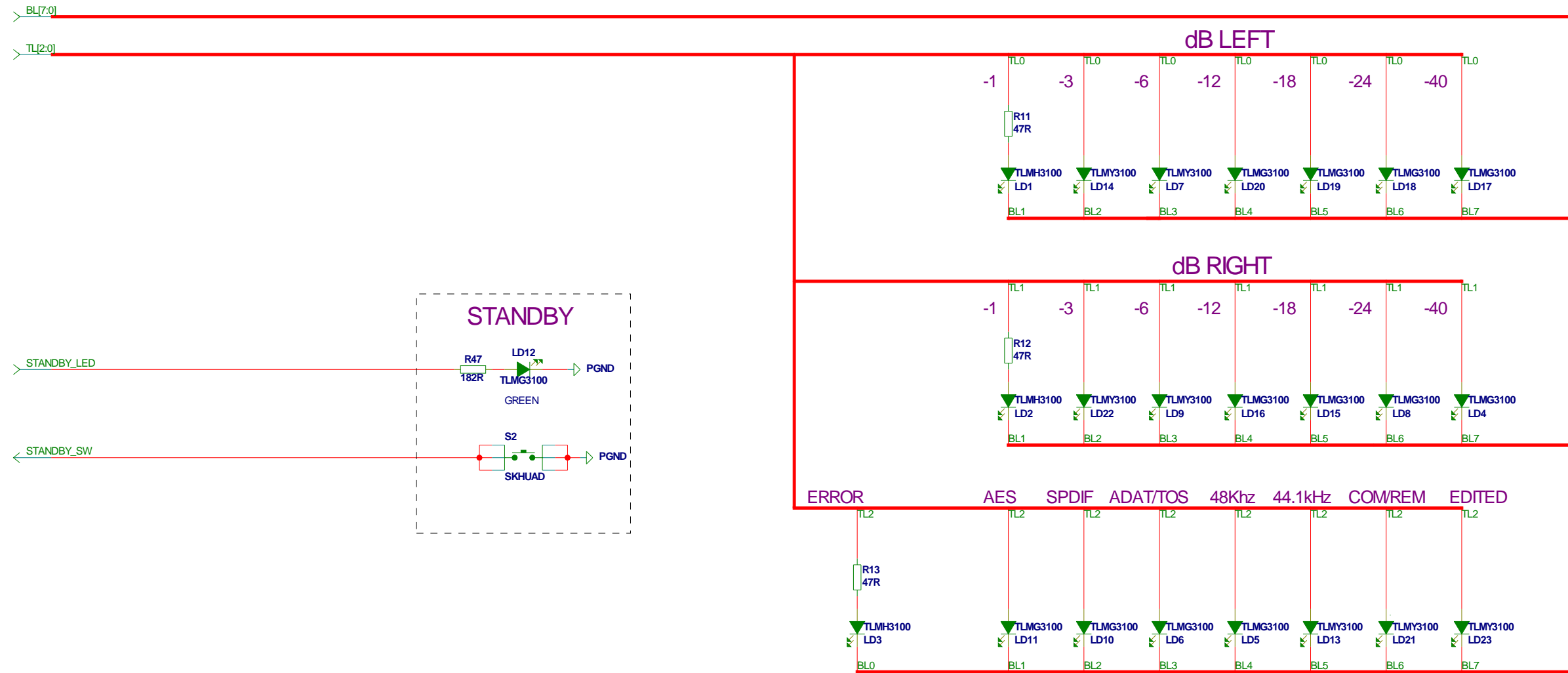

TC Electronic A/S		Designer NIM
Title VIKING 12	Module title LEFT FRONT PCB	
Number P12512	Revision CAB	Previous page 1
Date 6-29-2010_15:04	Filename LEFT_PCB	Page / of 3 / 6

# RIGHT PCB



Title		Module title		Designer
VIKING 12		RIGHT FRONT PCB		NIM
Number	Revision	Previous page		
P12512	CAB	1		
Date	Filename	Page / of		
6-29-2010_15:06	RIGHT_PCB	4 / 6		

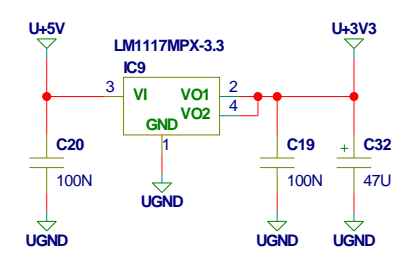
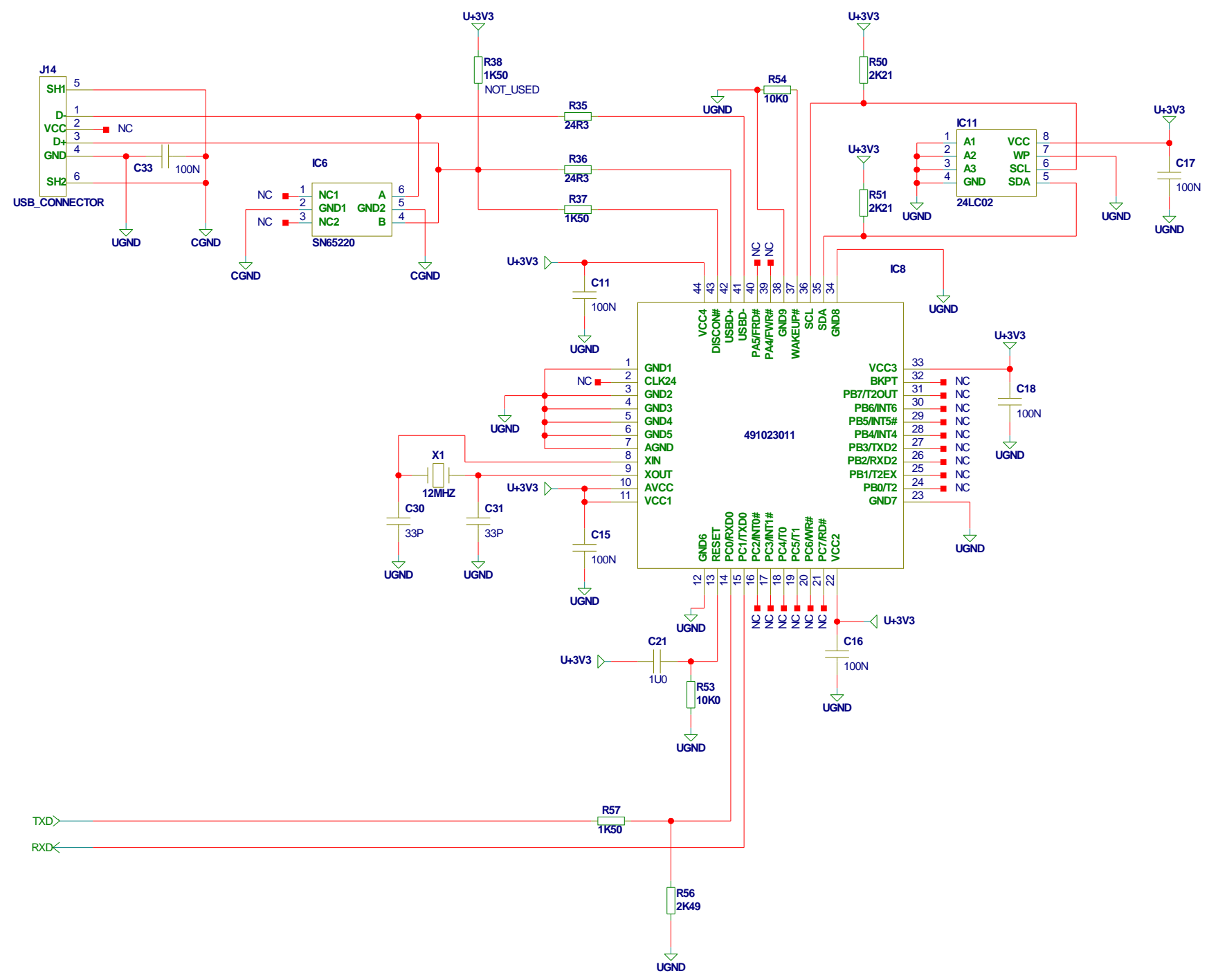

<b>TC Electronic A/S</b>		Designer NIM
Title VIKING 12		Module title USB MODULE
Number P12512	Revision CAB	Previous page 1
Date 6-14-2010_15:04	Filename USB	Page / of 6 / 6