

See application note for PCB Layout

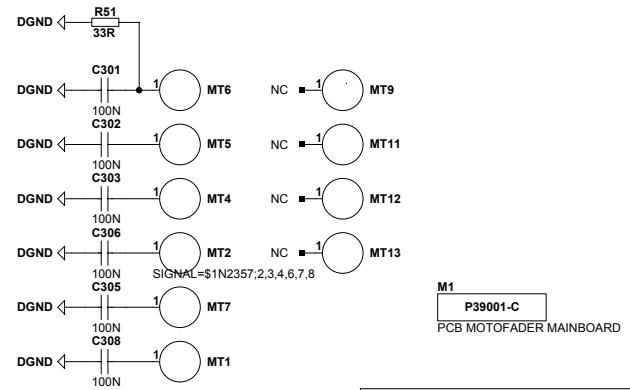

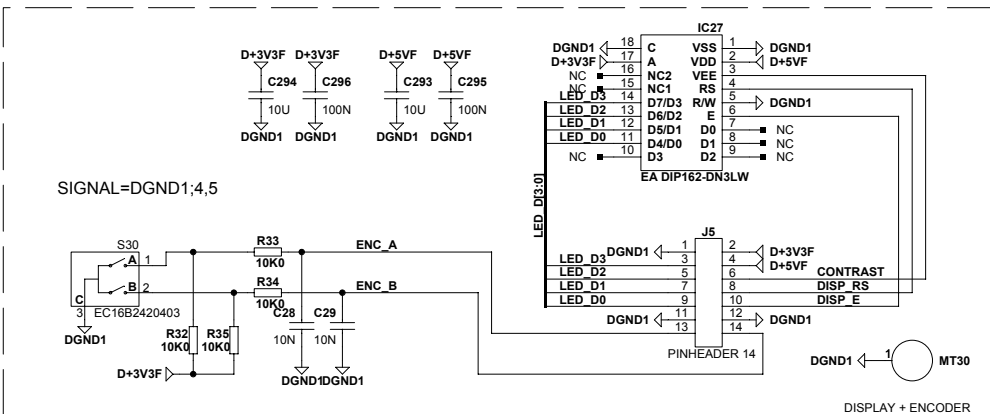
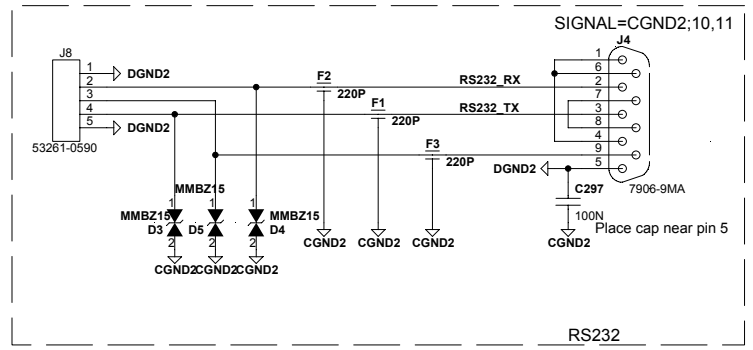
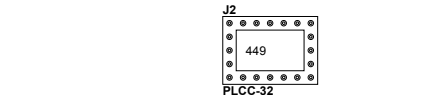
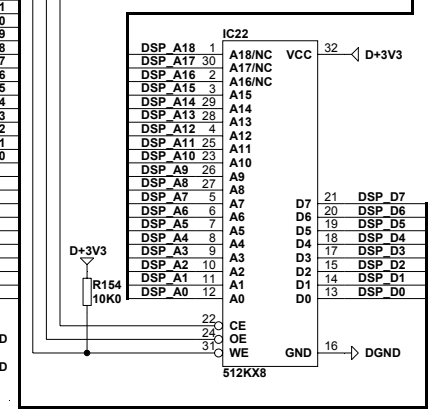
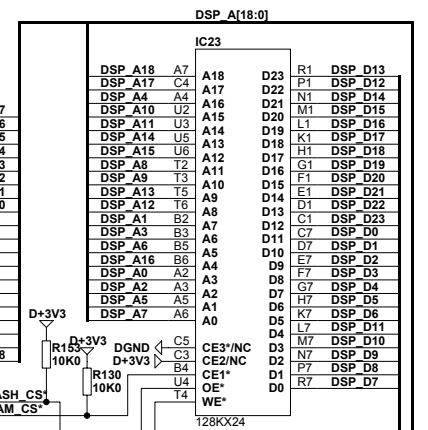
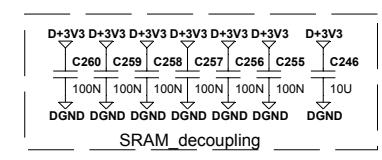
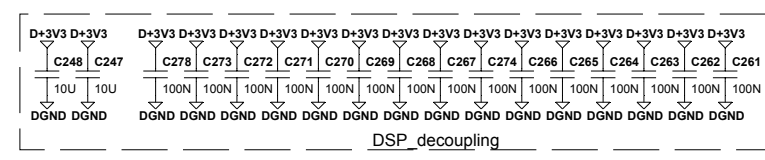
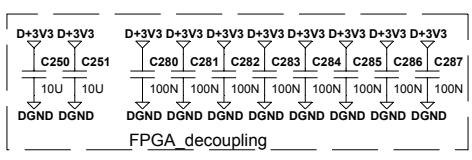
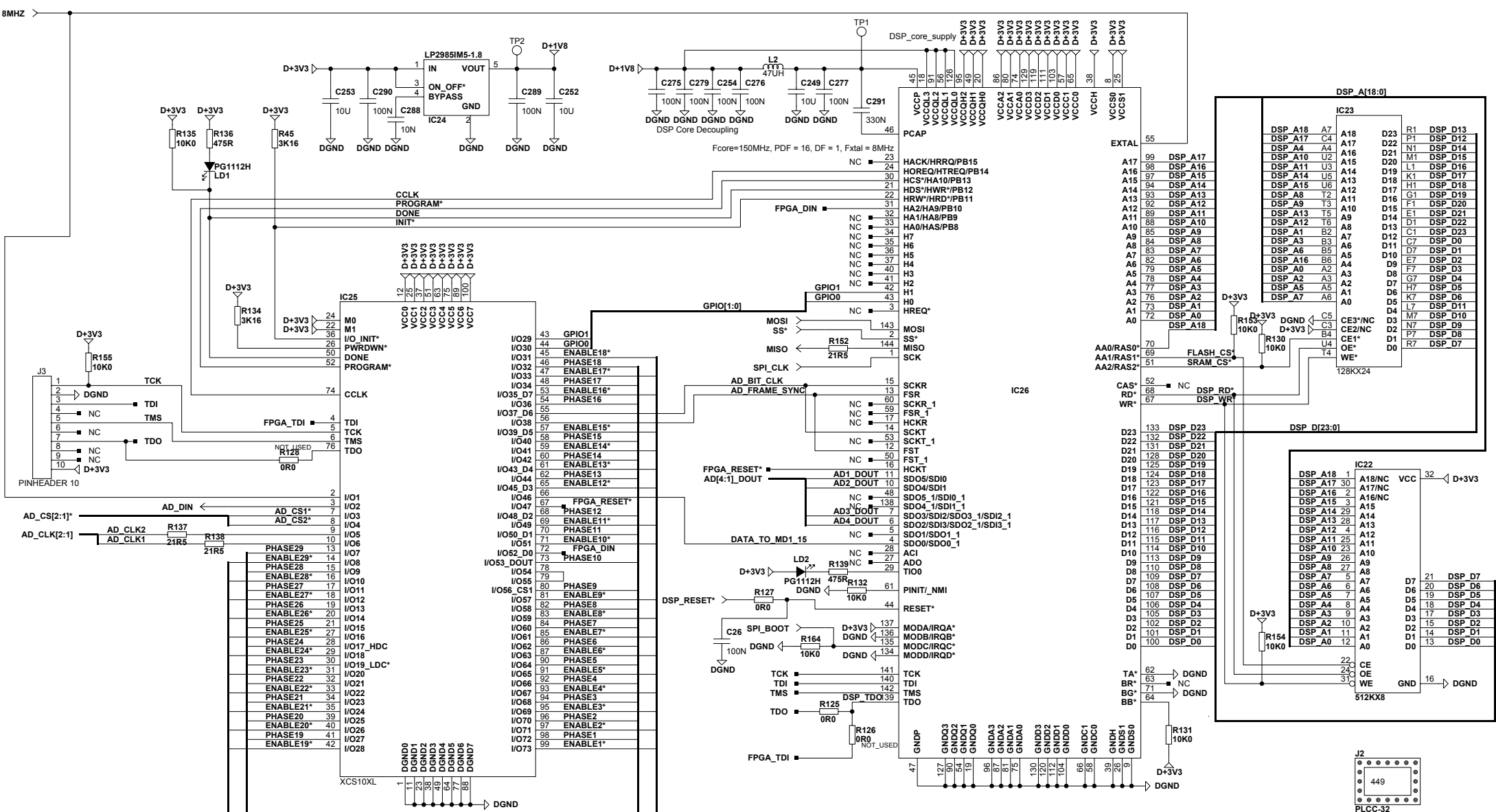

M1 P39001-C PCB MOTOFADER MAINBOARD

| | | | |
|-------------------|------------------|---------------|--------------|
| TC Electronic A/S | | Designer | HK/MC |
| Title | MOTOFADER | Module title | MOTOR DRIVER |
| Number | P39001 | Revision | CAA |
| Date | 11-28-2003 13:37 | Filename | P39001-CAA |
| | | Previous page | XX |
| | | Page / of | 1 / 8 |

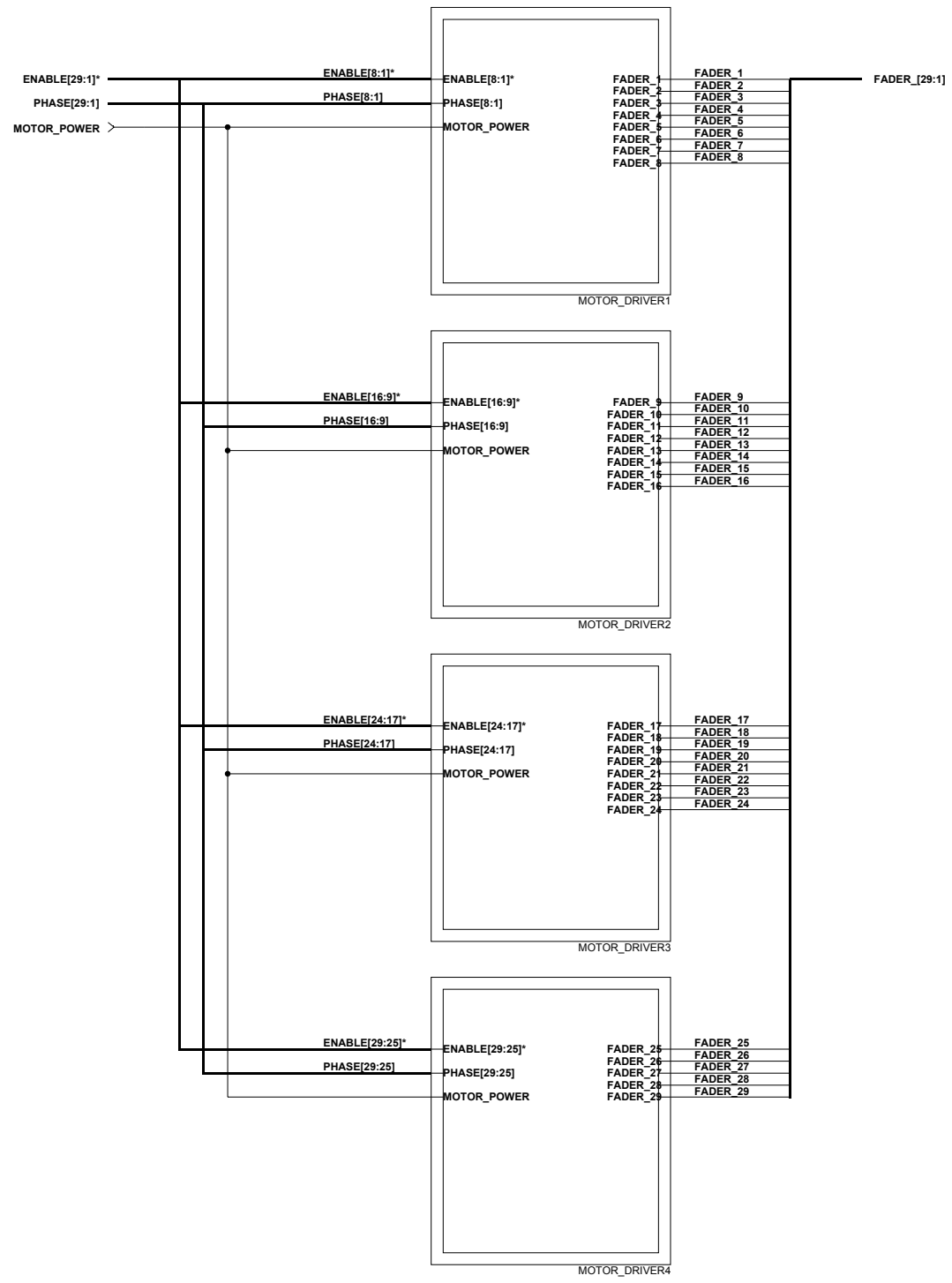

| | | | |
|--------------------------|------------------|---------------|-------------|
| TC Electronic A/S | | Designer | HK/MC |
| Title | MOTOFADER | Module title | DSP SECTION |
| Number | P39001 | Revision | CAA |
| Date | 11-10-2003 15:59 | Filename | DSP |
| | | Previous page | XX |
| | | Page / of | 2 / 8 |



MOTOR_POWER > 
 ENABLE[8:1]*
 PHASE[8:1]

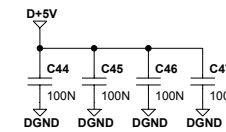
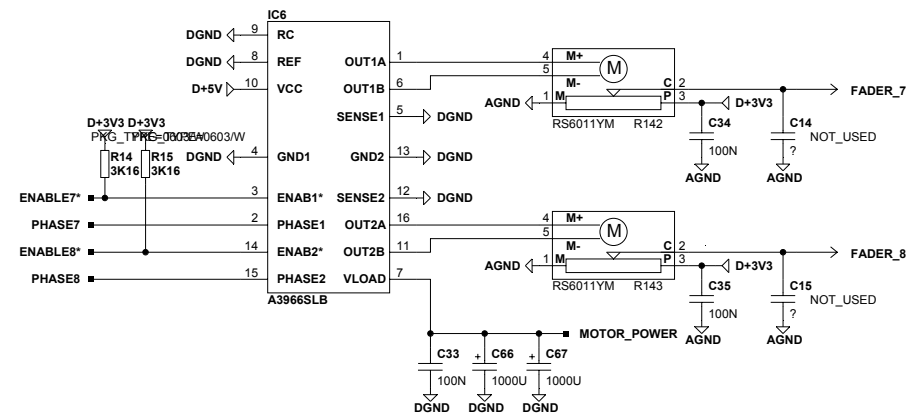
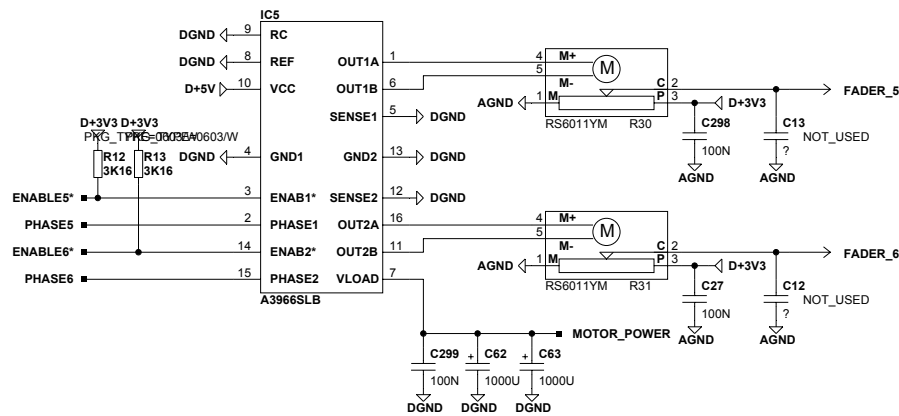
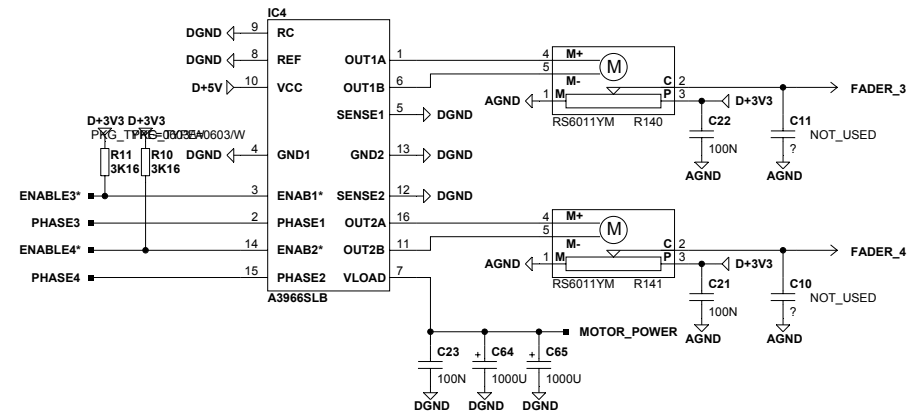
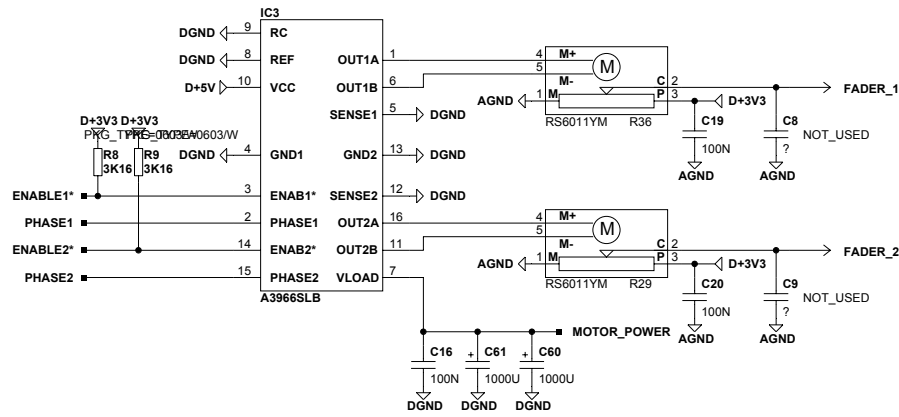

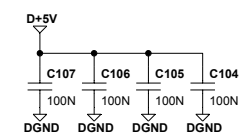
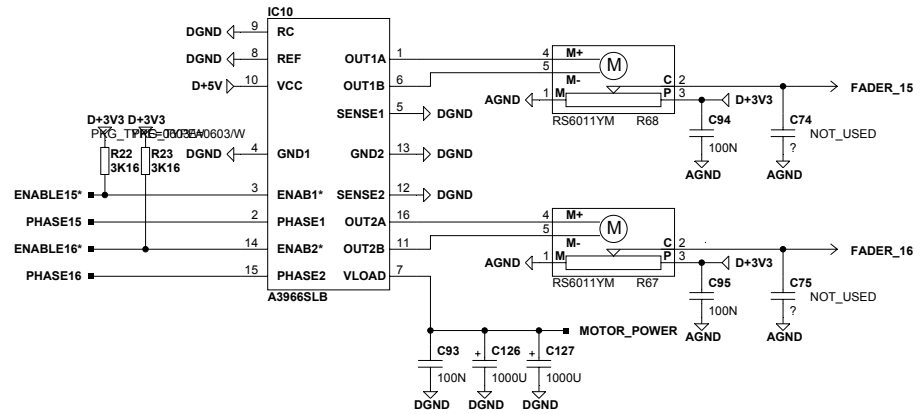
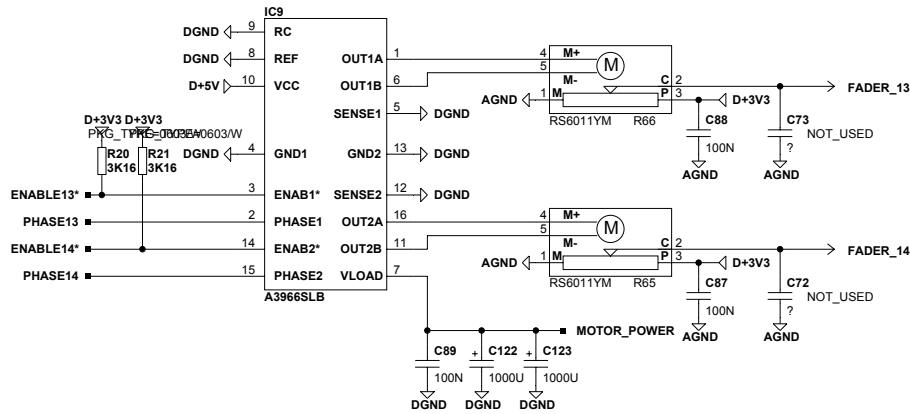
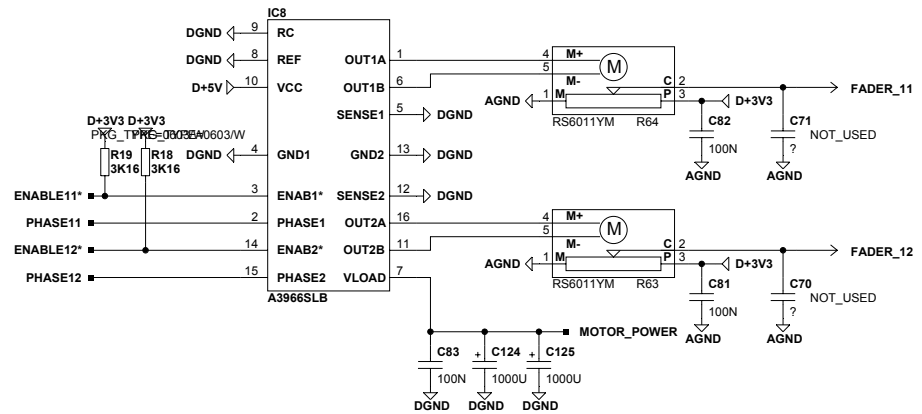
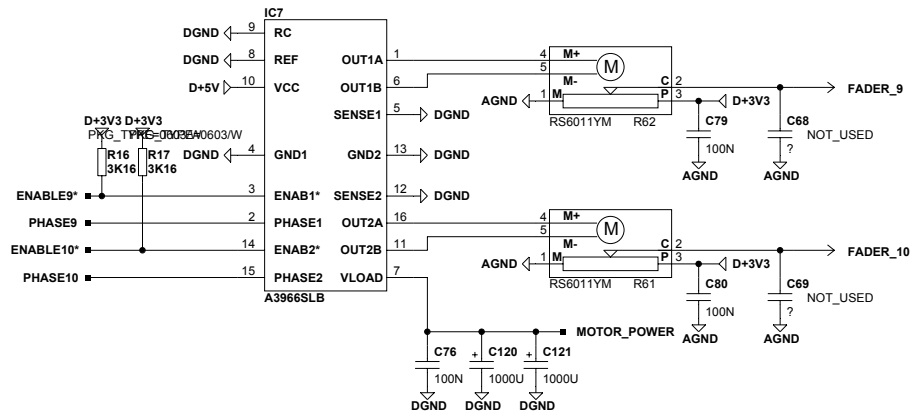

| | | |
|--------------------------|---------------------------|------------------------------|
| TC Electronic A/S | | Designer HK/MC |
| Title MOTOFADER | | Module title MOTOR DRIVER |
| Number P39001 | Revision CAA | Previous page 3 |
| Date 10-17-2003 10:27 | Filename MOTOR_DRIVER1 | Page / of 4 / 8 |

MOTOR_POWER >—————■
 ENABLE[16:9]* >—————■
 PHASE[16:9] >—————■



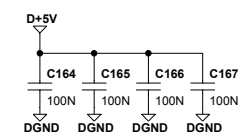
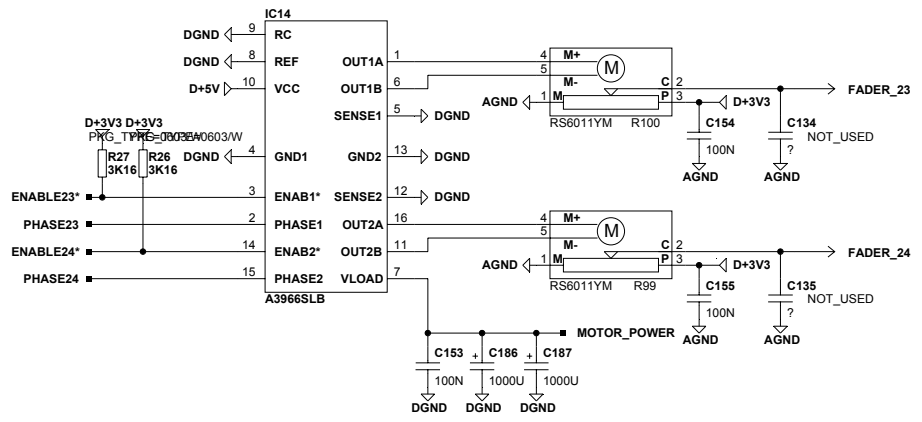
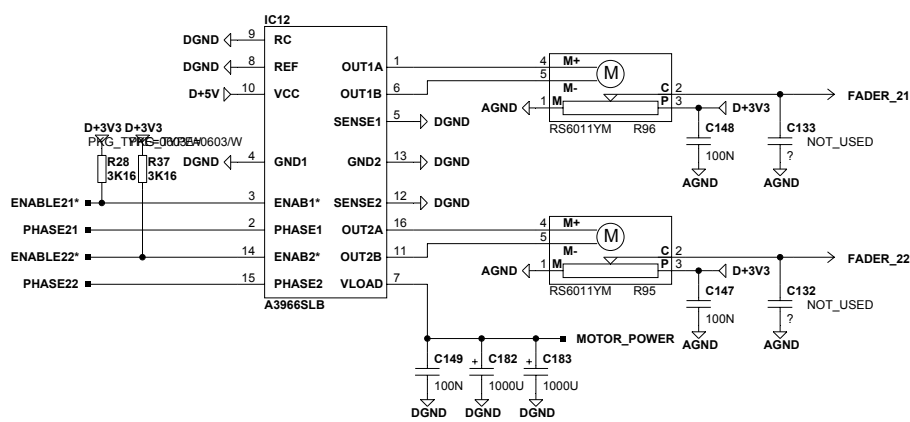
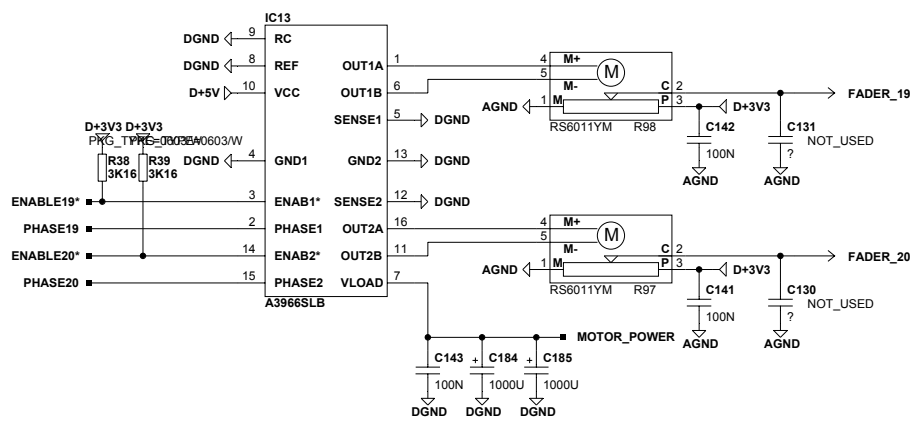
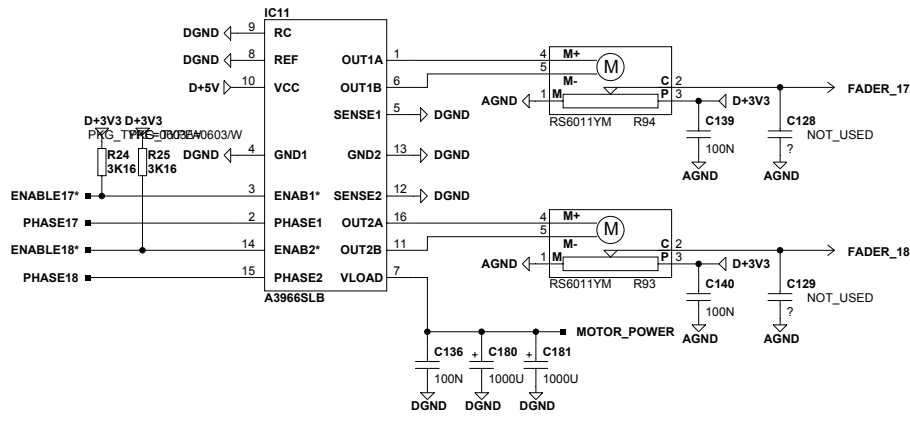

| | | |
|--------------------------|---------------------------|------------------------------|
| TC Electronic A/S | | Designer HK/MC |
| Title MOTOFADER | | Module title MOTOR DRIVER |
| Number P39001 | Revision CAA | Previous page 3 |
| Date 10-17-2003 10:27 | Filename MOTOR_DRIVER2 | Page / of 4 / 8 |

MOTOR_POWER > 
 ENABLE[24:17]* > 
 PHASE[24:17] > 



| | | |
|--------------------------|---------------------------|------------------------------|
| TC Electronic A/S | | Designer HK/MC |
| Title MOTOFADER | | Module title MOTOR DRIVER |
| Number P39001 | Revision CAA | Previous page 3 |
| Date 10-17-2003 10:27 | Filename MOTOR_DRIVER3 | Page / of 4 / 8 |

MOTOR_POWER > 
 ENABLE[29:25]* > 
 PHASE[29:25] > 

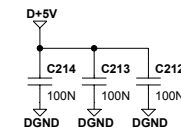
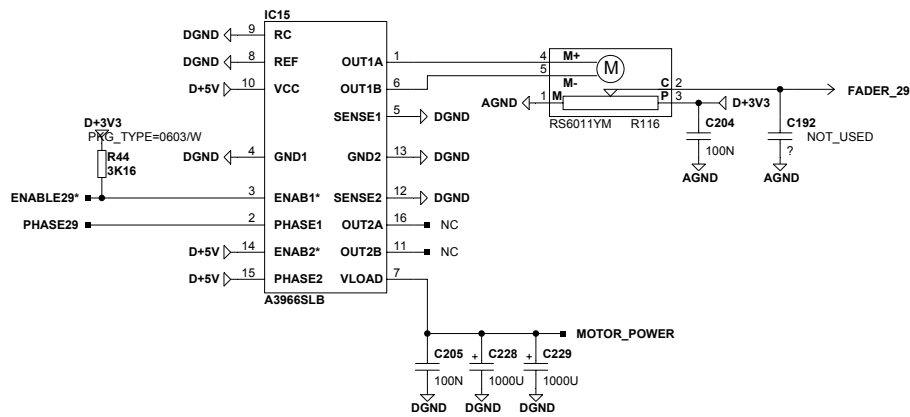
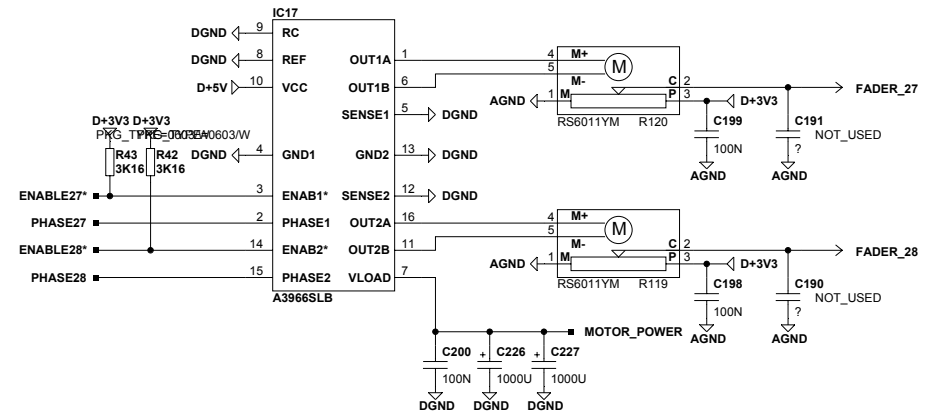
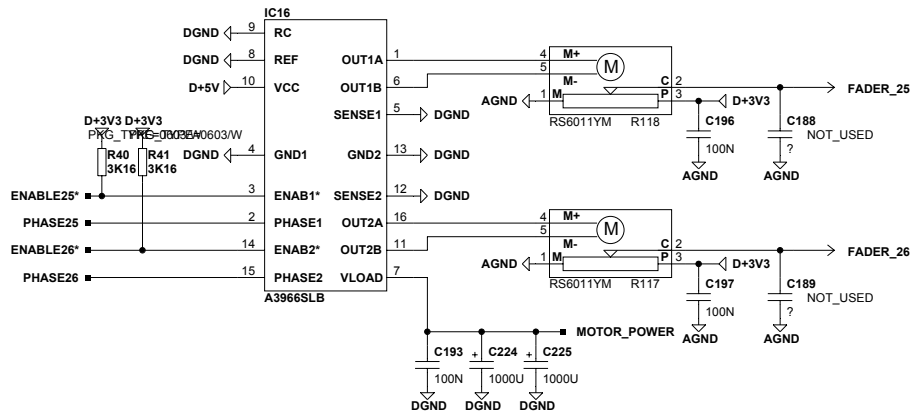

| | | | |
|------------------|---------------|---------------|----------|
| Title | | Module title | Designer |
| MOTOFADER | | MOTOR DRIVER | HK/MC |
| Number | Revision | Previous page | |
| P39001 | CAA | 3 | |
| Date | Filename | Page / of | |
| 10-17-2003 10:28 | MOTOR_DRIVER4 | 4 / 8 | |

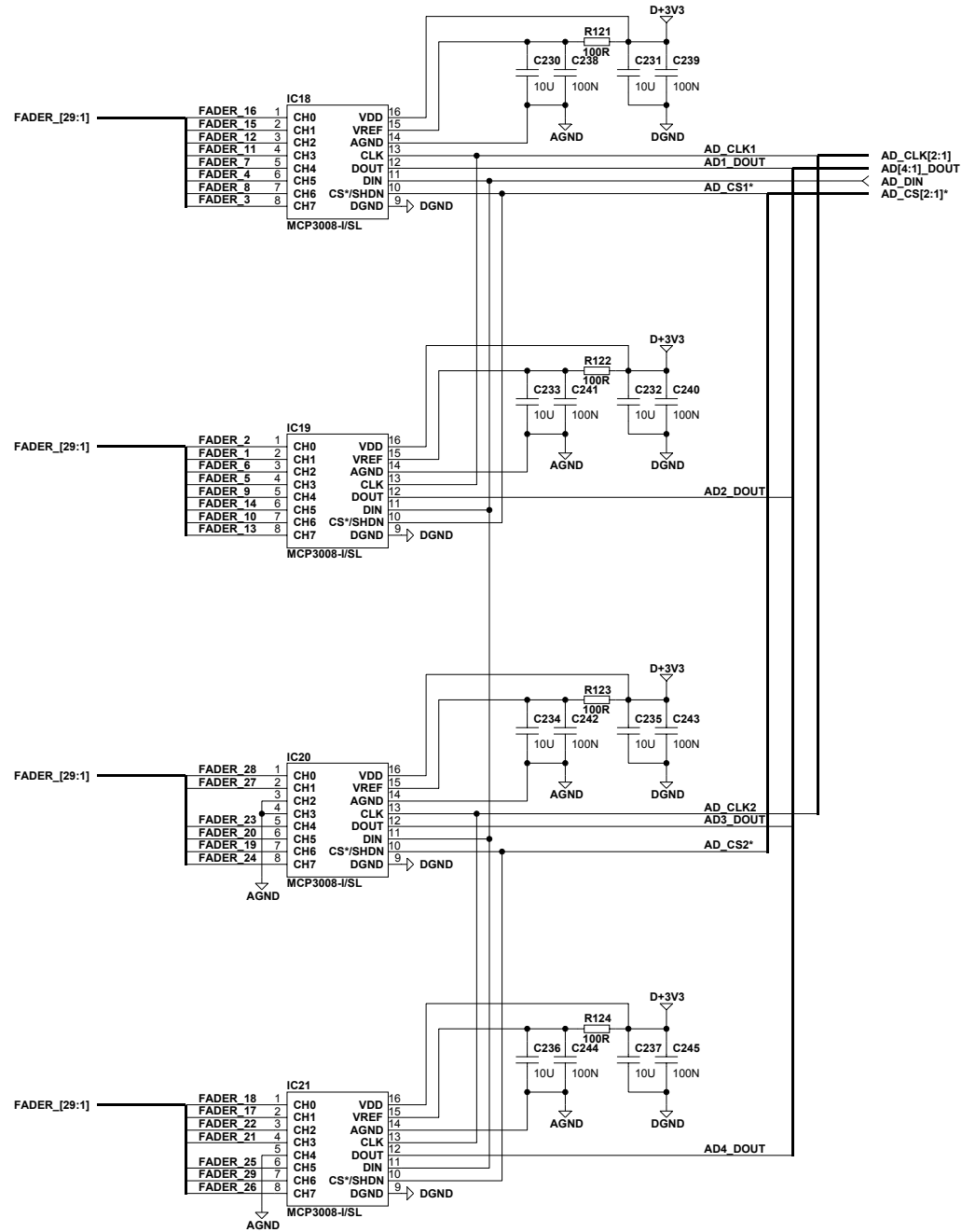

| | | | |
|-----------------|----------|---------------|----------|
| Title | | Module title | Designer |
| MOTOFADER | | ADC SECTION | HK/MC |
| Number | Revision | Previous page | |
| P39001 | CAA | 1 | |
| Date | Filename | Page / of | |
| 11-7-2003 12:49 | ADC | 8 / 8 | |