

M1  
P22637-D

tc electronic a/s				Designer(s) DA/SP	
Title ATR42				Module title MODULE TITLE	
Number P22637	Revision D	Variant A	Version A	Board type MAINBOARD	
Date 21/11/2016:16:33	Filename p22628-B			Page / of 1 / 10	

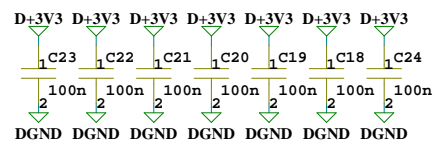

tc electronic a/s				Designer(s) DA/SP	
Title ATR42				Module title MODULE TITLE	
Number P22637	Revision D	Variant A	Version A	Board type MAINBOARD	
Date 21/11/2016:16:33	Filename memory			Page / of 1 / 10	

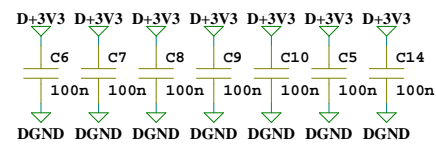
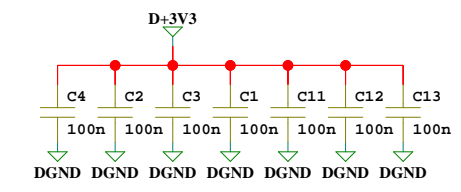
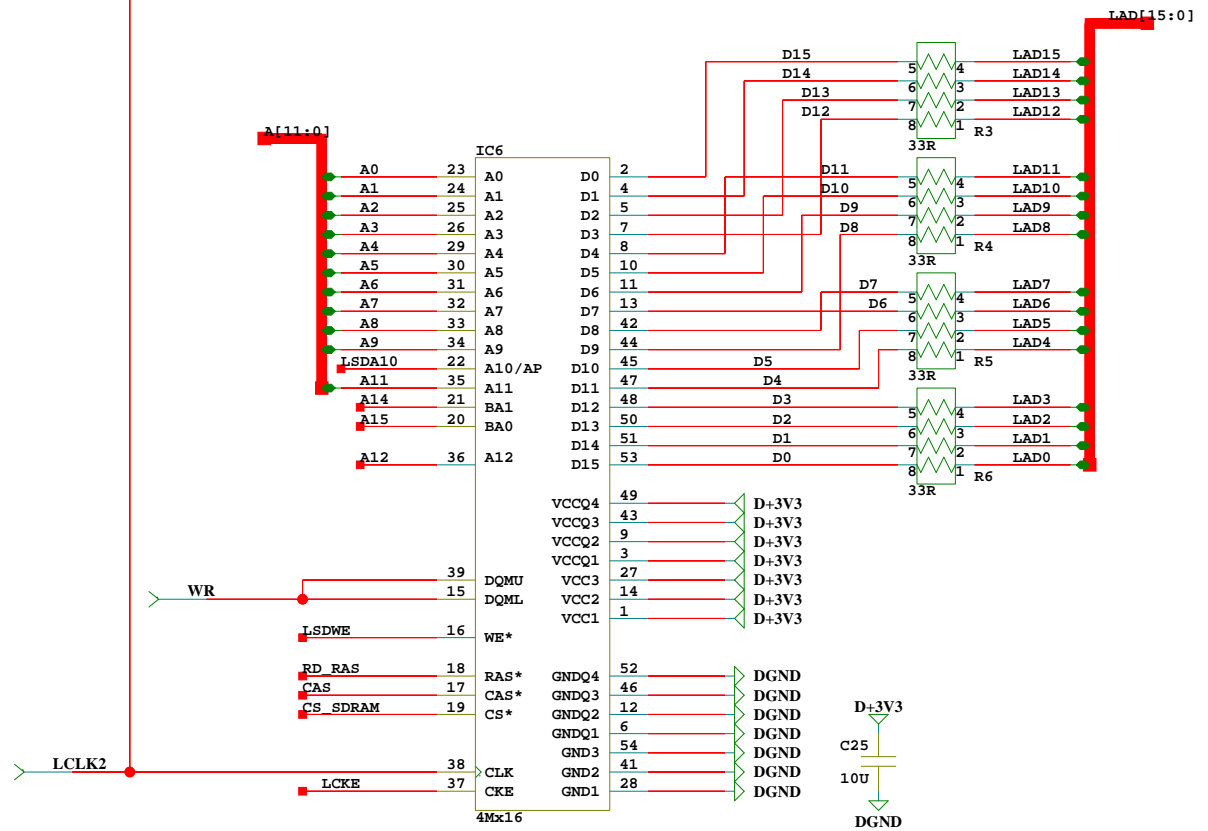
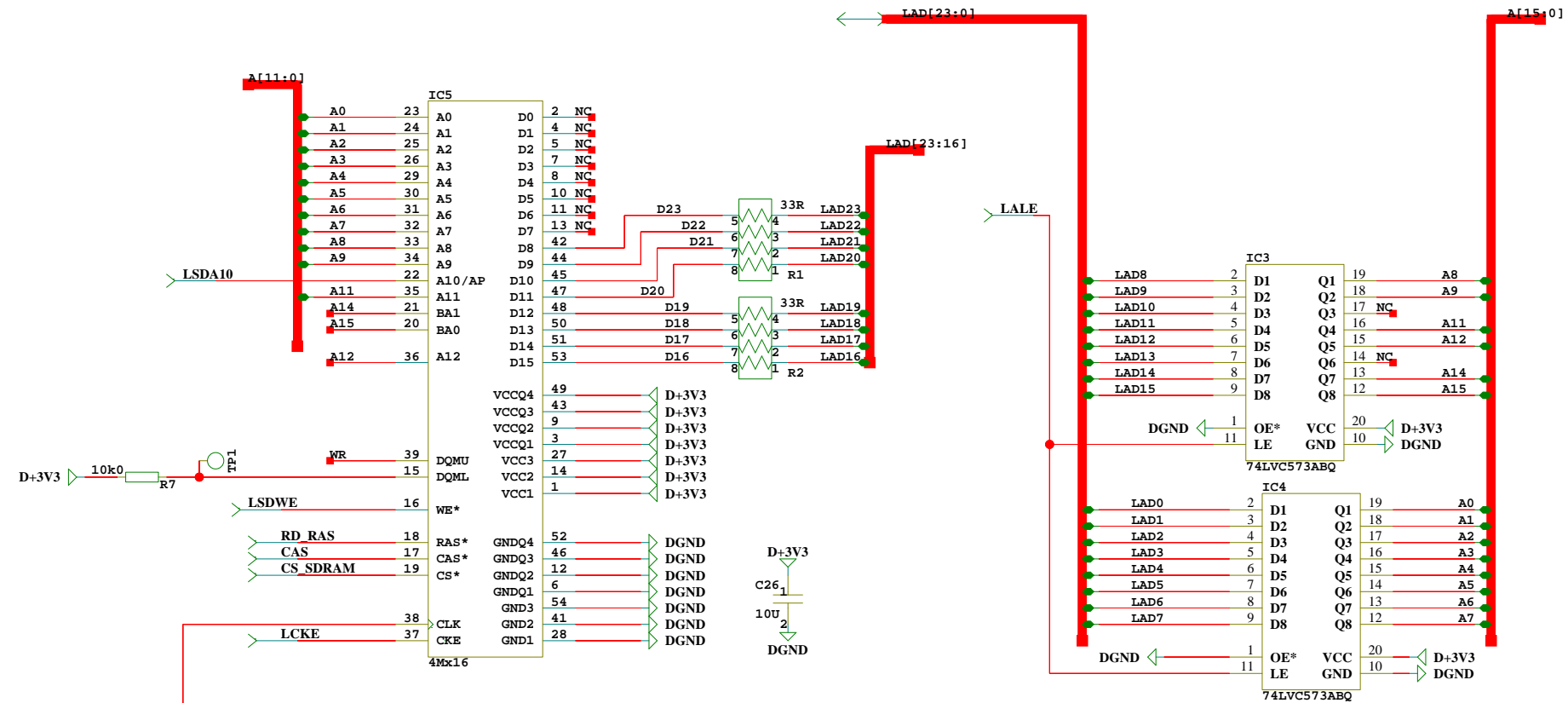
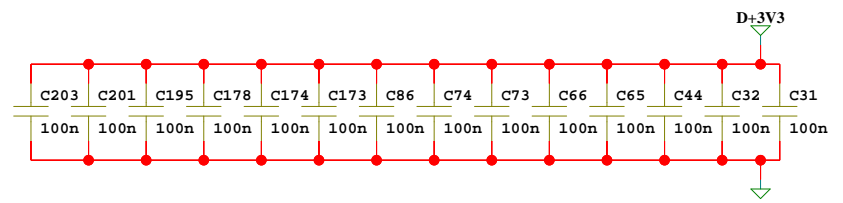
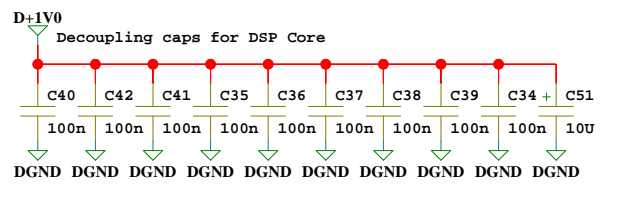
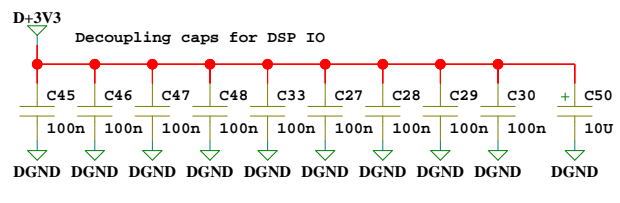
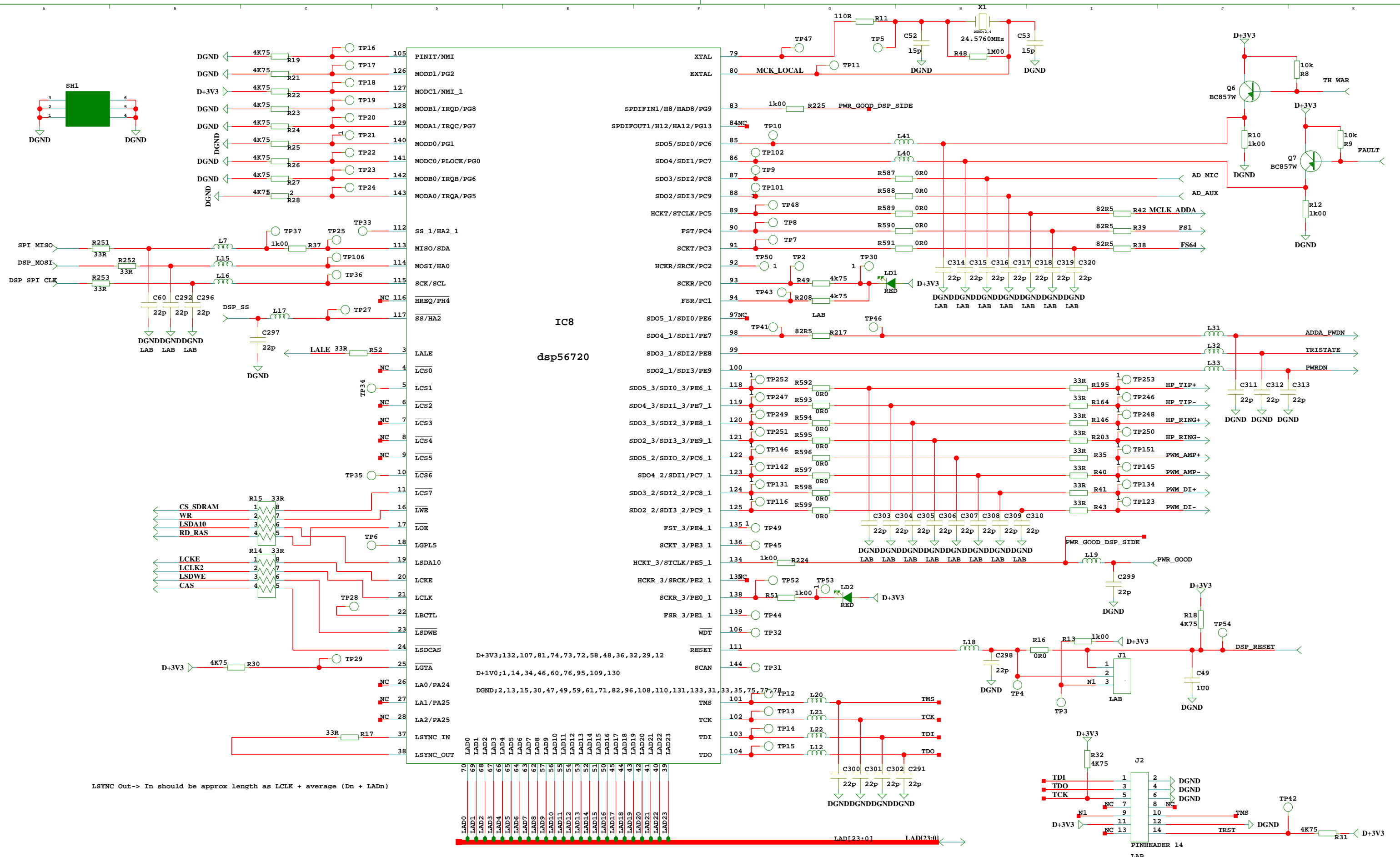

<b>tc electronic a/s</b>				Designer(s)	DA/SP
Title ATR42				Module title MODULE TITLE	
Number P22637	Revision D	Variant A	Version A	Board type MAINBOARD	
Date 21/11/2016:16:34	Filename dsp720			Page / of 1 / 10	

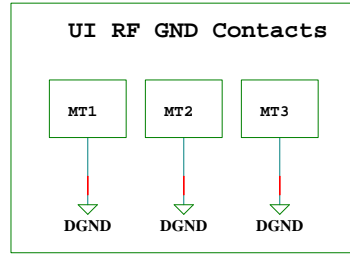
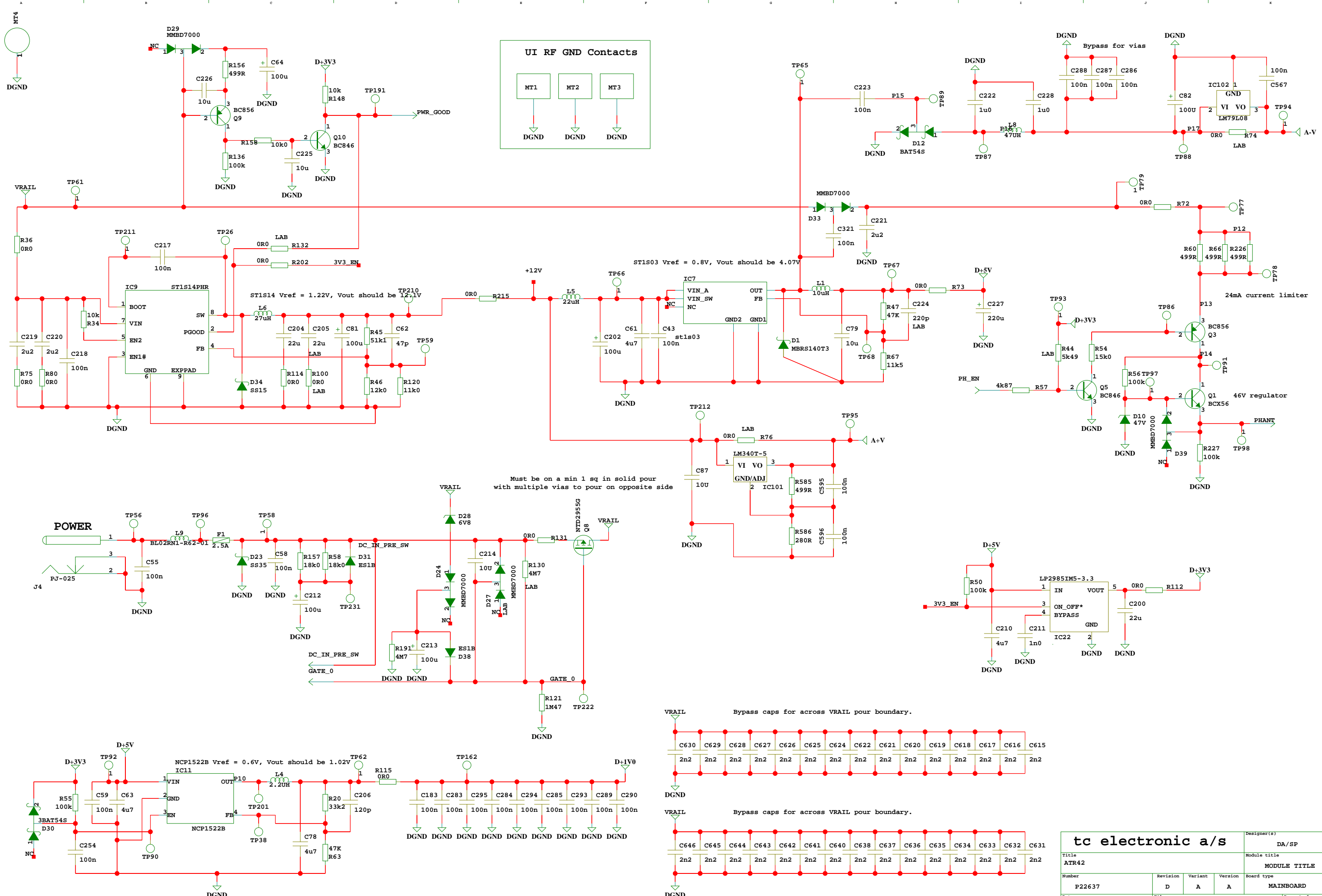

Must be on a min 1 sq in solid pour with multiple vias to pour on opposite side

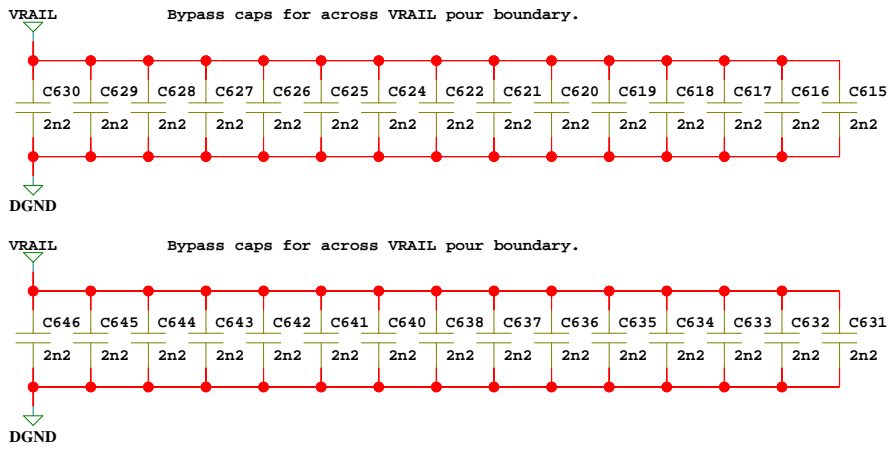

<b>tc electronic a/s</b>				Designer(s)	DA/SP
Title ATR42				Module title MODULE TITLE	
Number P22637	Revision D	Variant A	Version A	Board type MAINBOARD	
Date 21/11/2016:16:33	Filename power_supplies			Page / of 1 / 10	

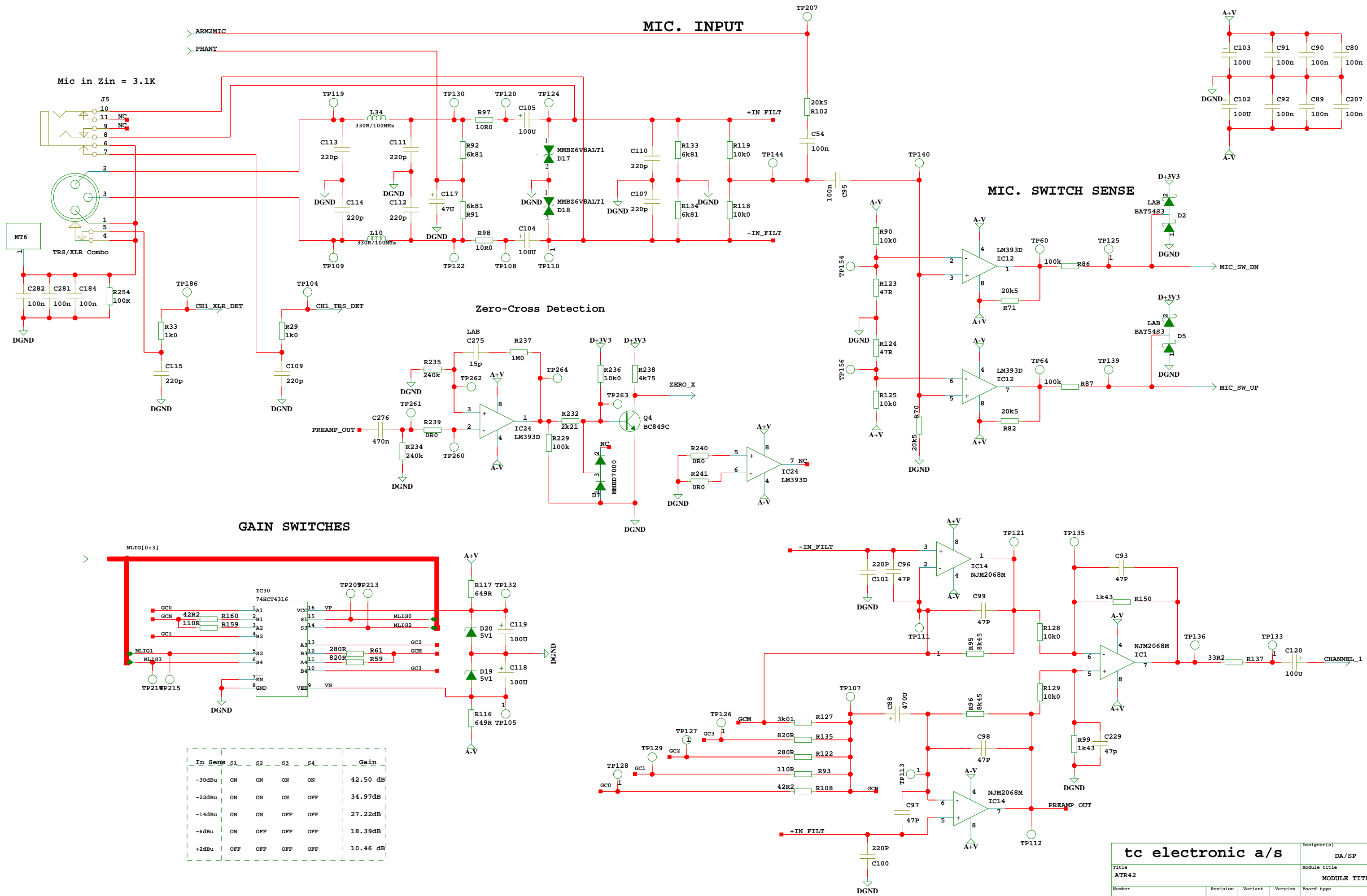

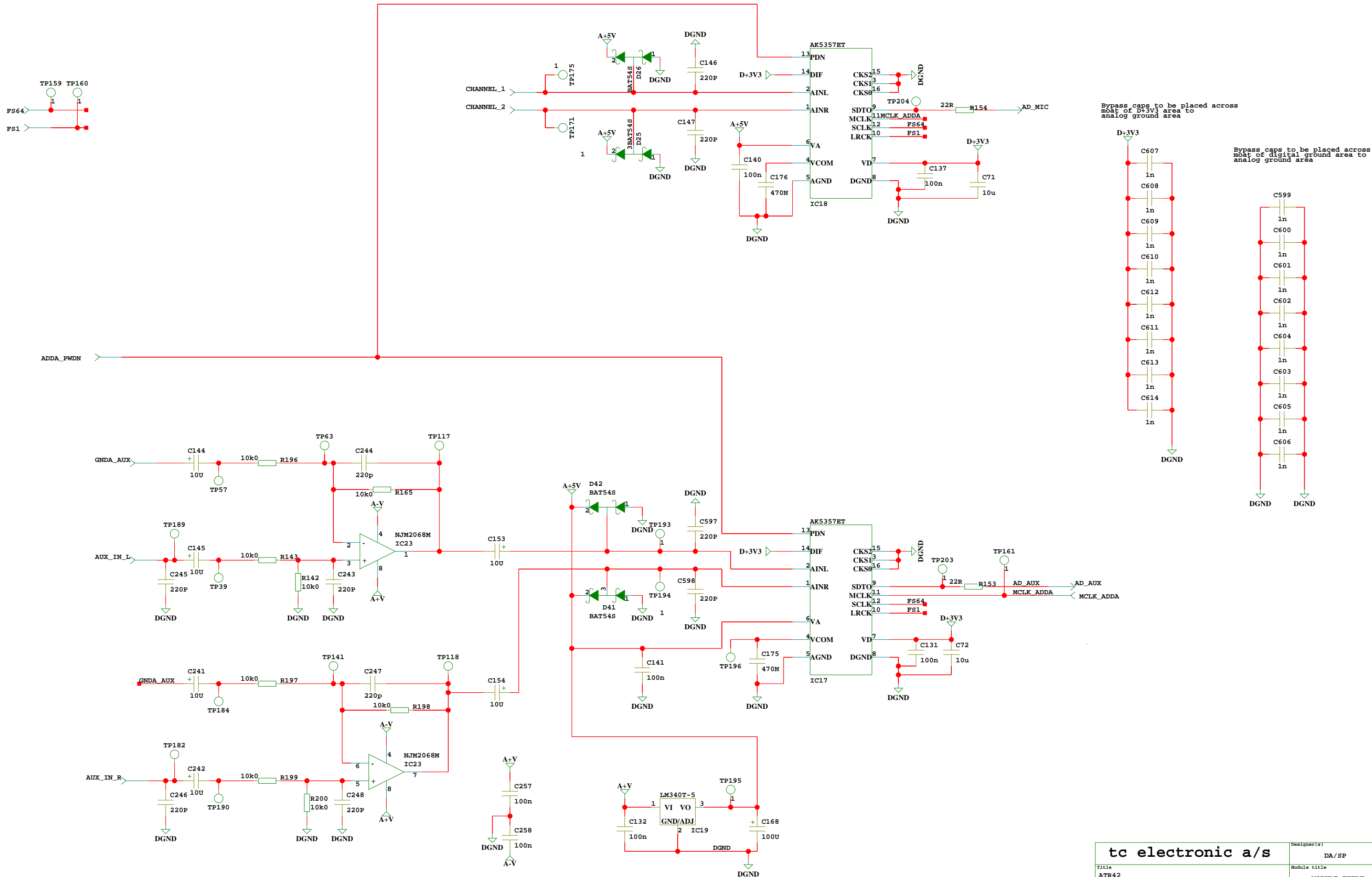

Bypass caps to be placed across most of D+3V3 area to analog ground area

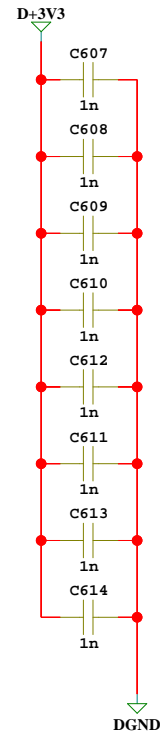

Bypass caps to be placed across most of digital ground area to analog ground area

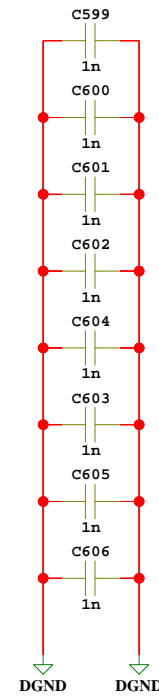

tc electronic a/s				Designer(s)	DA/SP
ATR42				Module title	
				MODULE TITLE	
Number	Revision	Variant	Version	Board type	
P22637	D	A	A	MAINBOARD	
Date	Filename			Page / of	
21/11/2016:16:34	analog2digital			1 / 10	

5-Pole Butterworth LPF  $f_c = 50\text{kHz}$

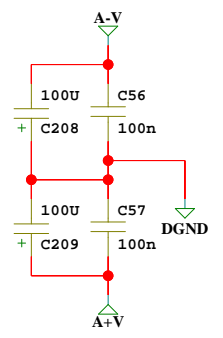
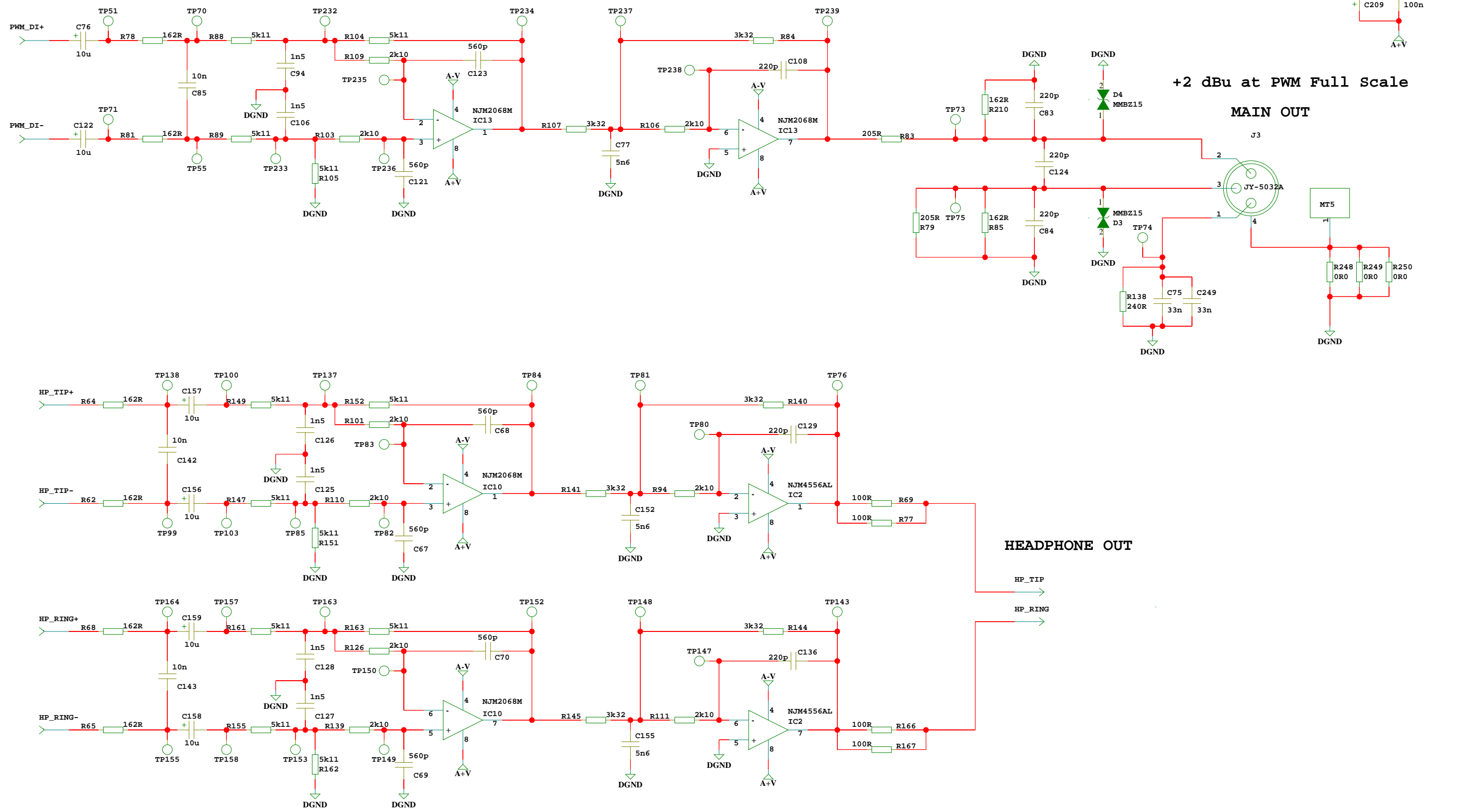

+2 dBu at PWM Full Scale

MAIN OUT

HEADPHONE OUT

HP\_TIP

HP\_RING

tc electronic a/s				Designer(s) DA/SP	
Title ATR42				Module title MODULE TITLE	
Number P22637	Revision D	Variant A	Version A	Board type MAINBOARD	
Date 21/11/2016:16:33	Filename analog_output			Page / of 1 / 10	

Inst In Sensitivity  
-19 dBu to +14 dBu

### INST. INPUT

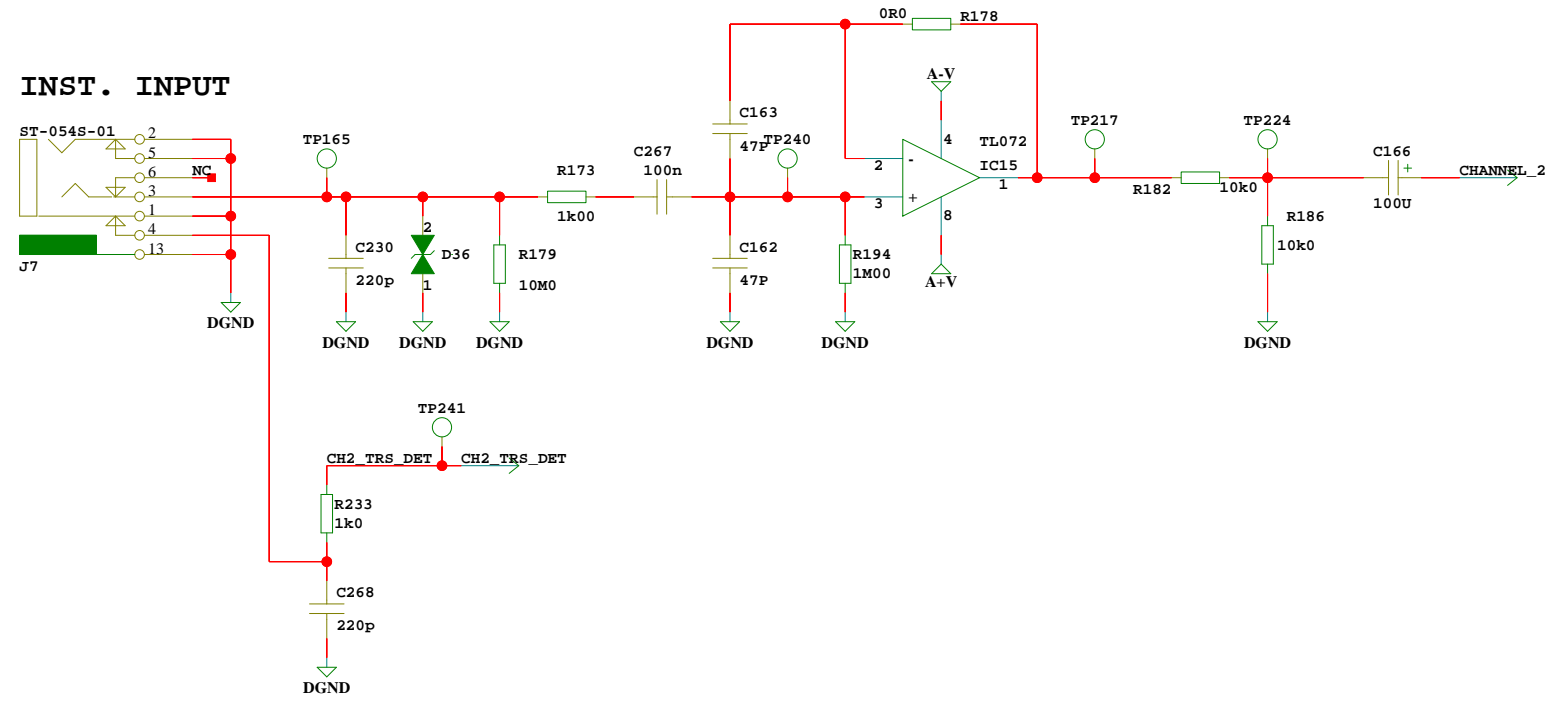

### AUX. INPUT

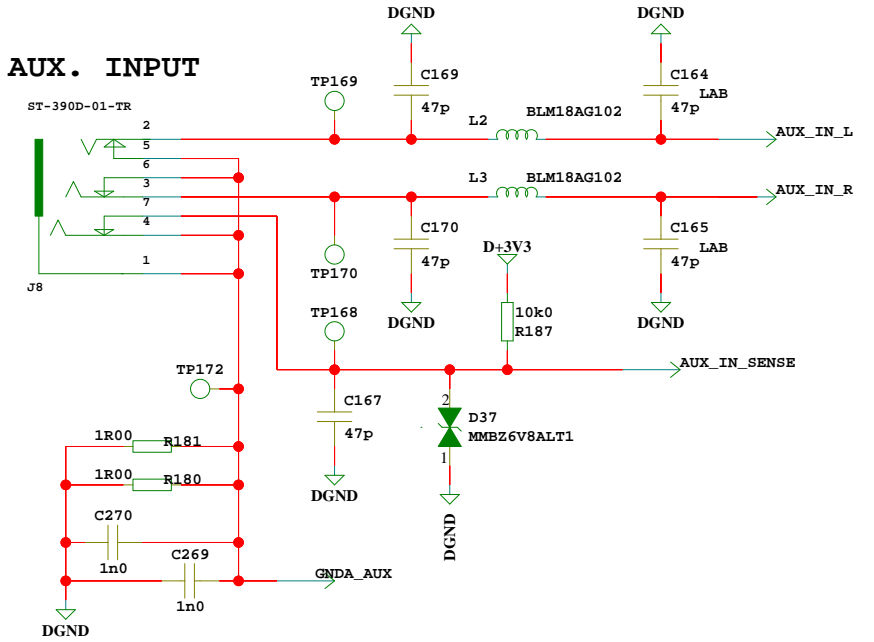

### SWITCH INPUT

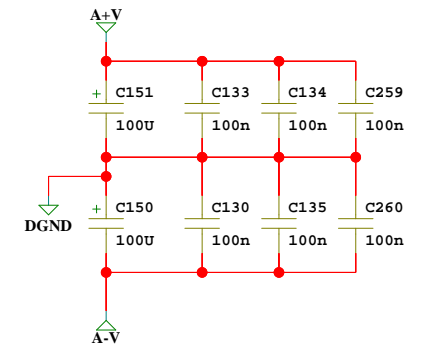
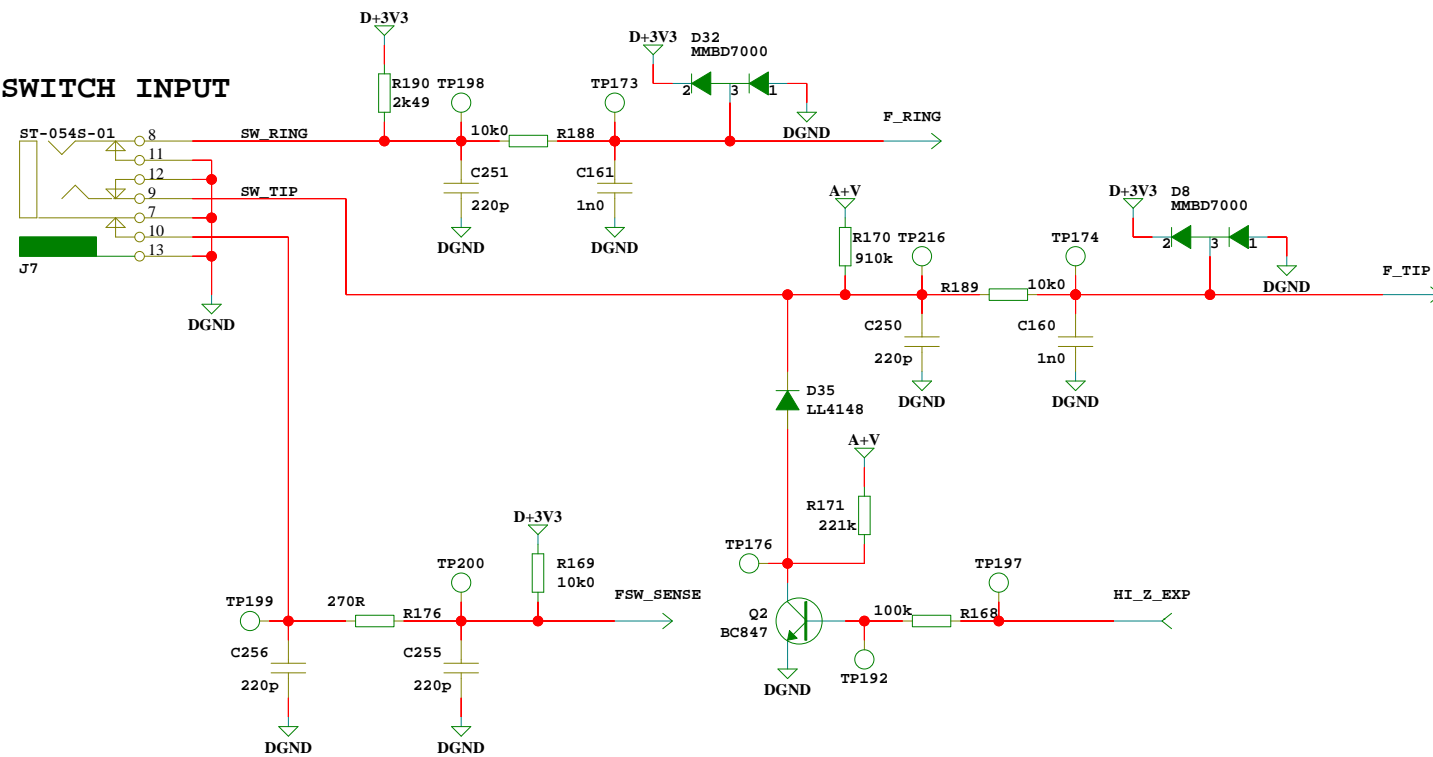

tc electronic a/s				Designer(s) DA/SP	
Title ATR42				Module title MODULE TITLE	
Number P22637	Revision D	Variant A	Version A	Board type MAINBOARD	
Date 21/11/2016:16:34	Filename channel2_input			Page / of 1 / 10	



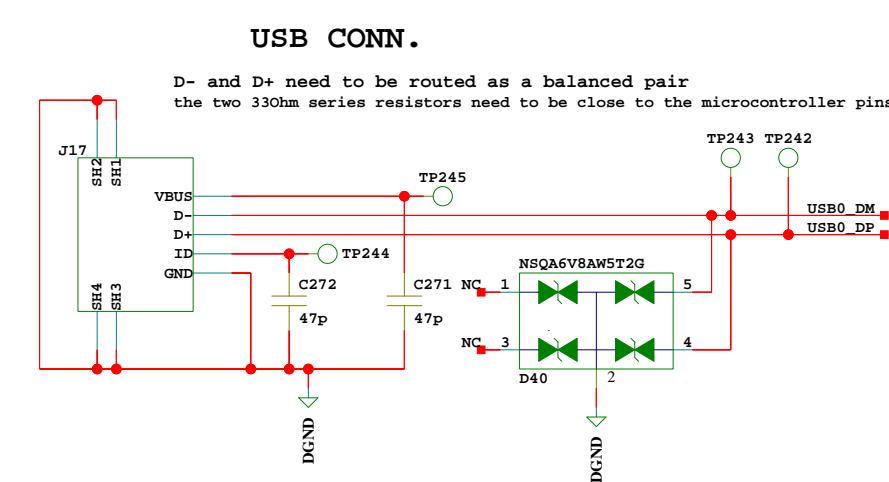
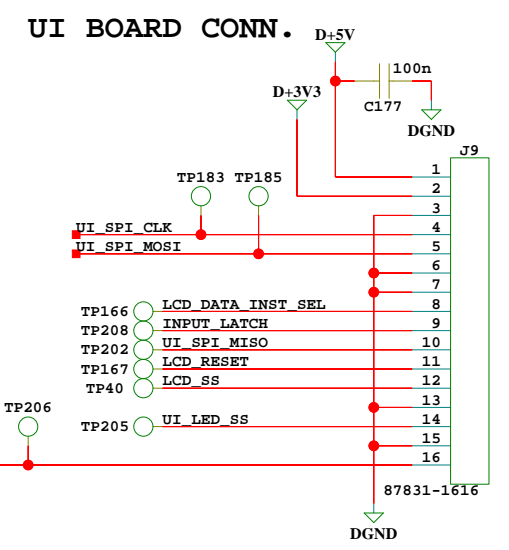
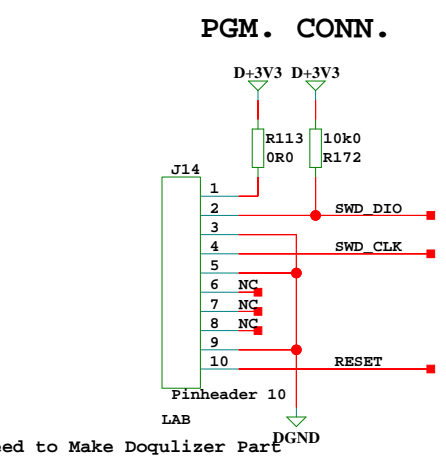
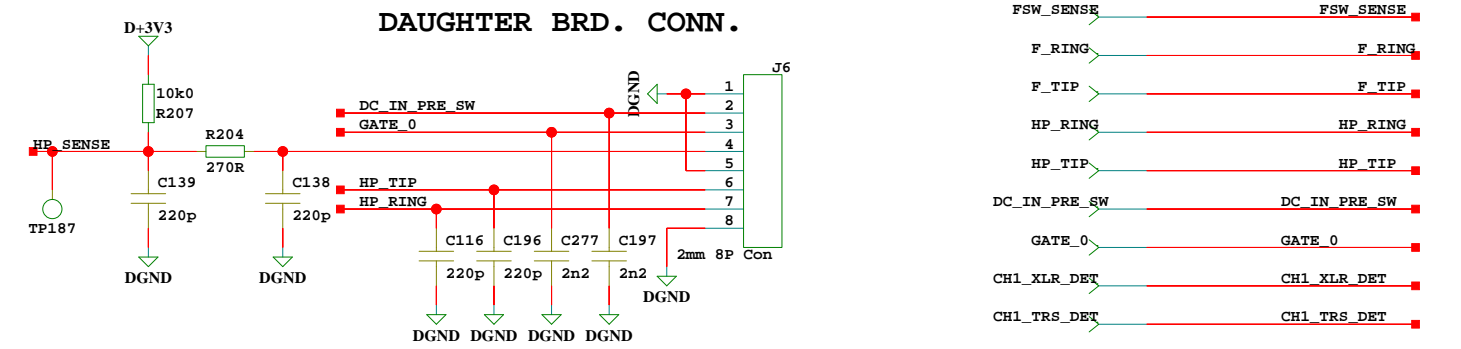
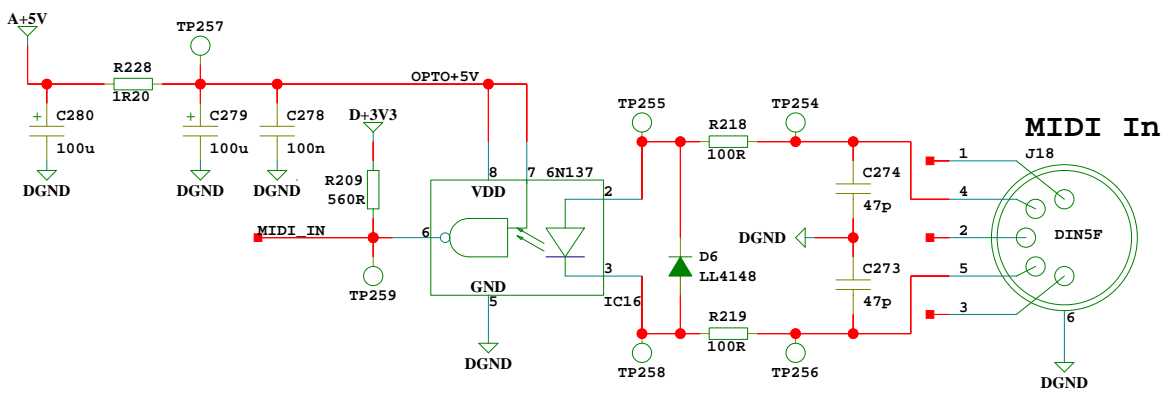
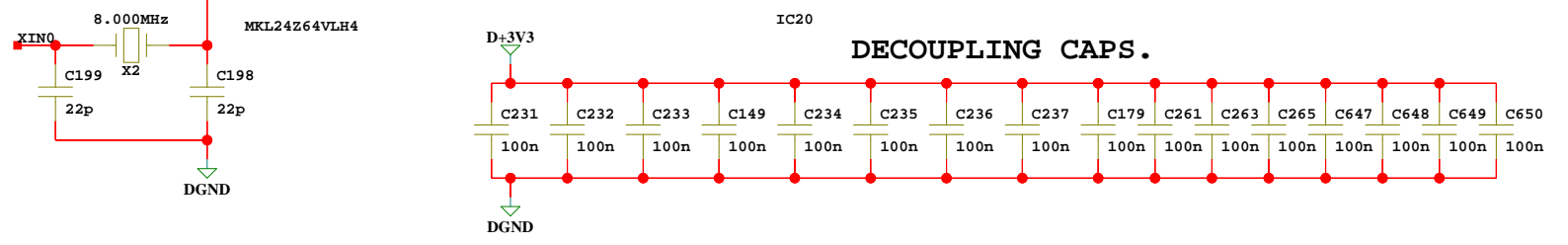
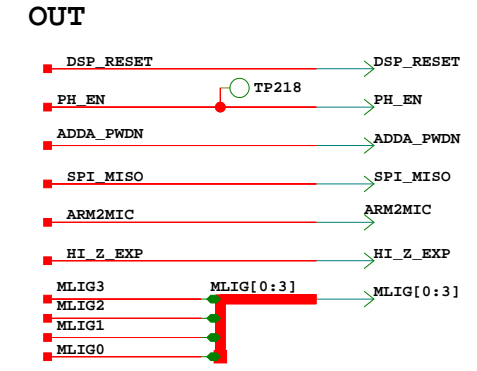
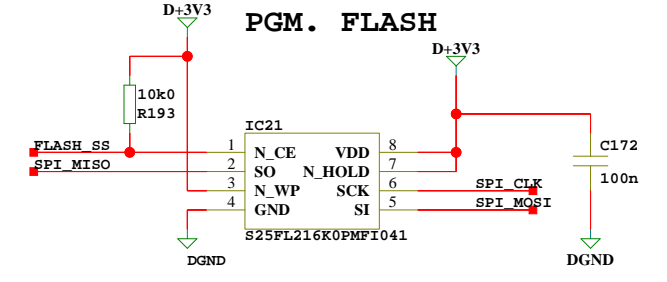
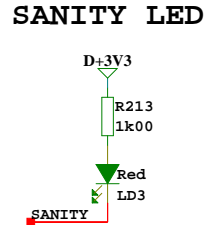
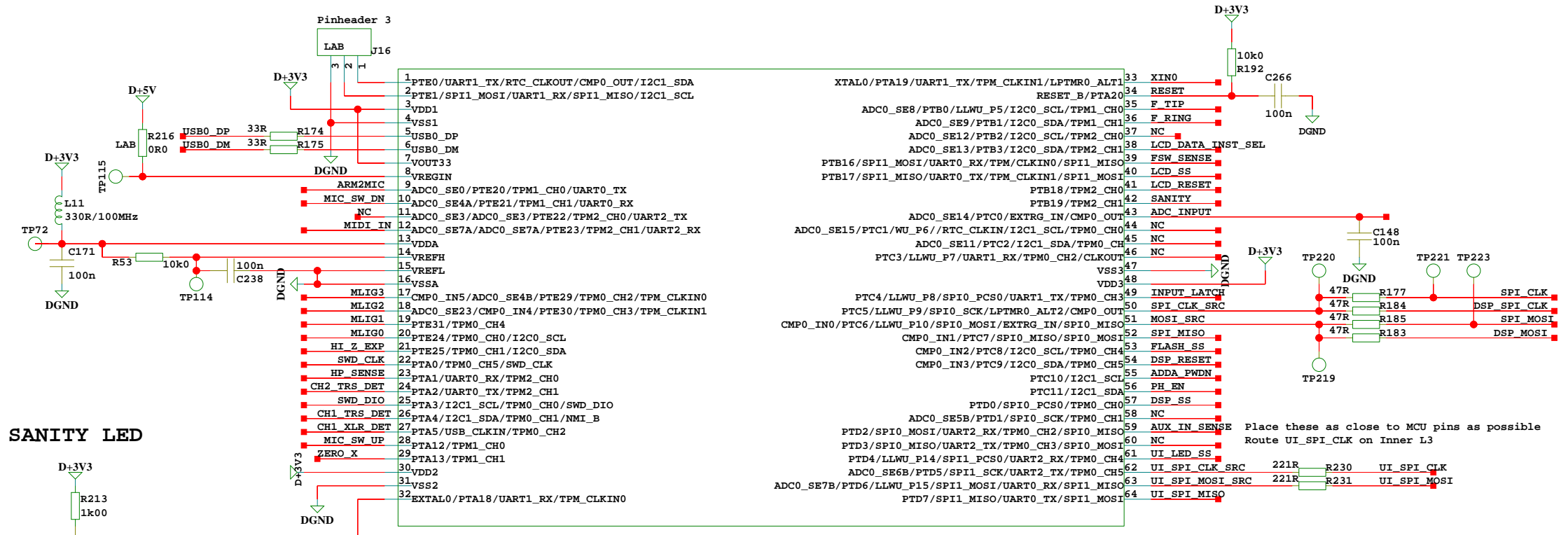

tc electronic a/s				Designer(s)		DA/SP	
Title ATR42				Module title MODULE TITLE			
Number P22637				Revision D		Variant A	
Date 21/11/2016:16:34				Version A		Board type MAINBOARD	
Filename Control				Page / of 1 / 10			

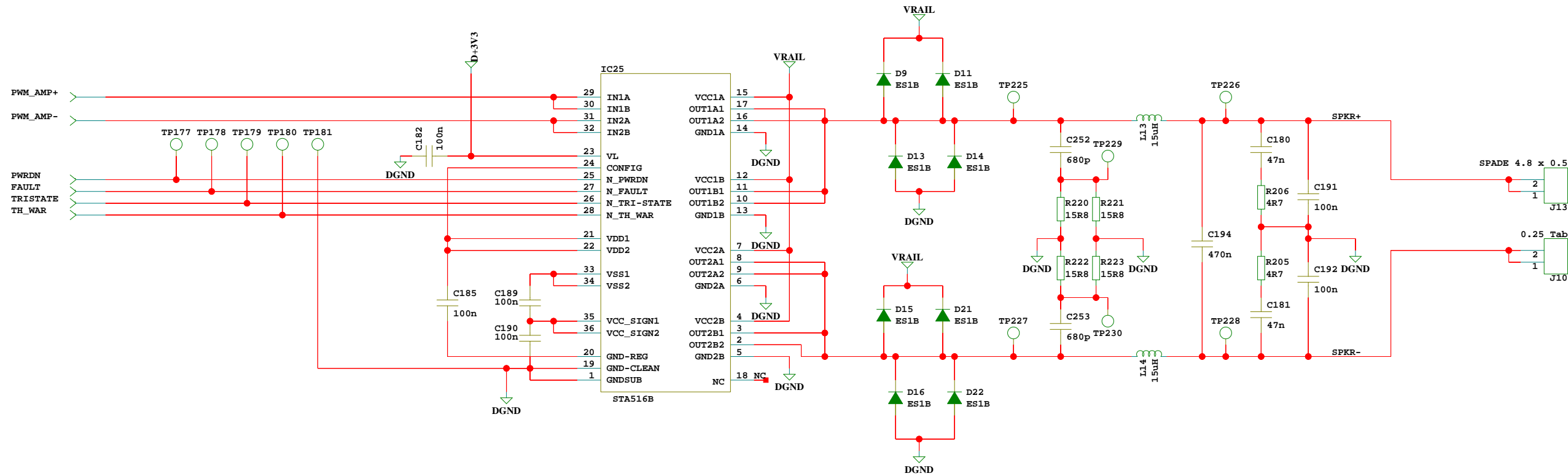

**HEATSINK**

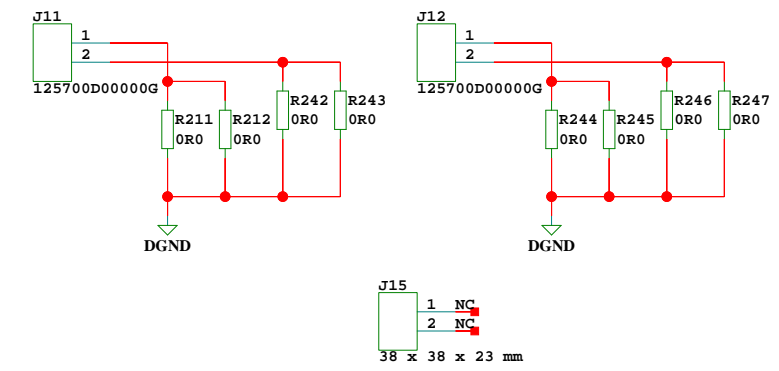
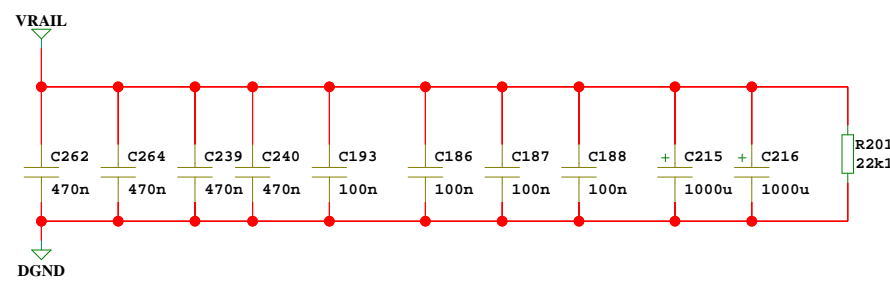

tc electronic a/s				Designer(s) DA/SP	
Title ATR42				Module title MODULE TITLE	
Number P22637		Revision D	Variant A	Version A	Board type MAINBOARD
Date 21/11/2016:16:34		Filename Power_Amplifier			Page / of 1 / 10