

TC Electronic A/S		Designer	HK/MC
		Module title	
Title XWIZ HOST ETHERNET		HOST_PROCESSOR	
Number P30301	Revision CAC	Previous page 1	Page / of 2 / 11
Date 1-28-2004 15:15	Filename HOST_PROCESSOR		

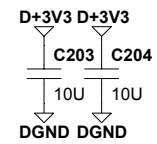

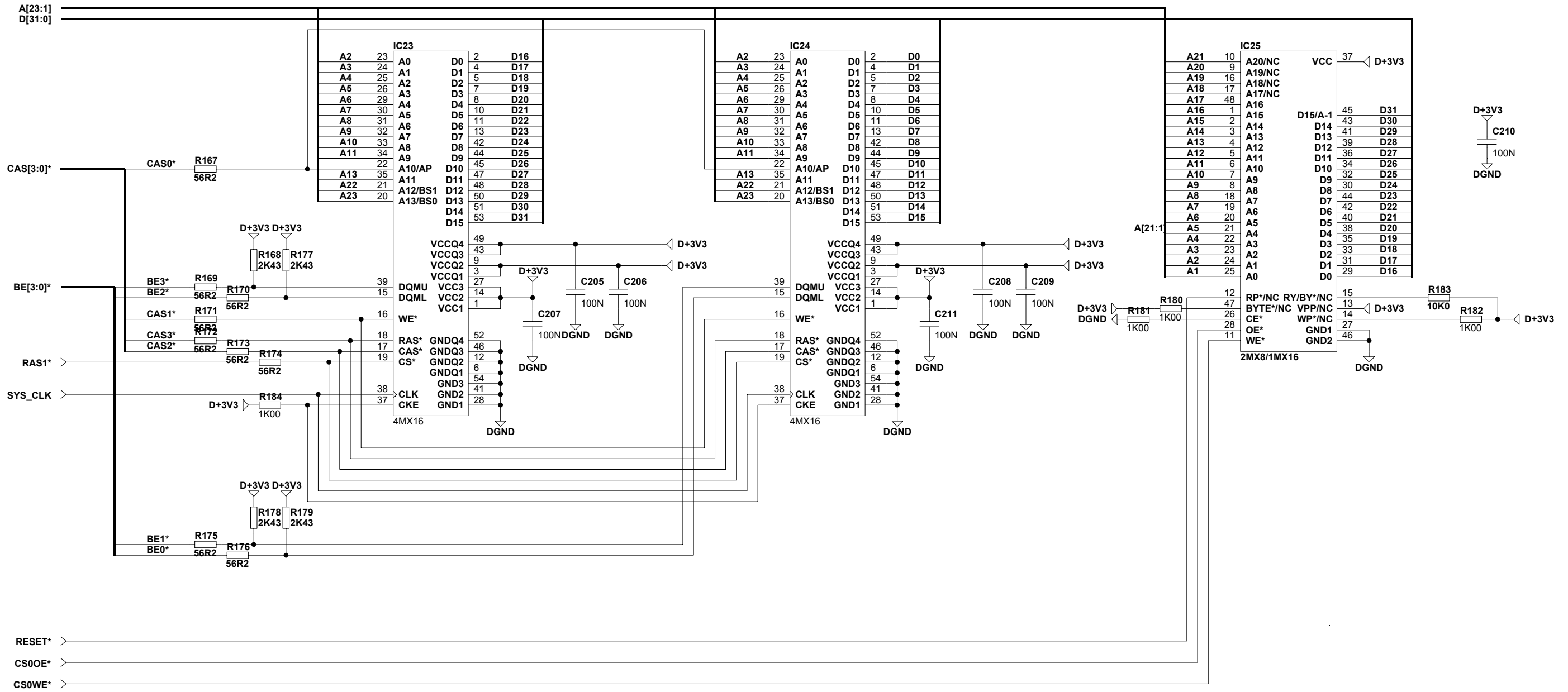
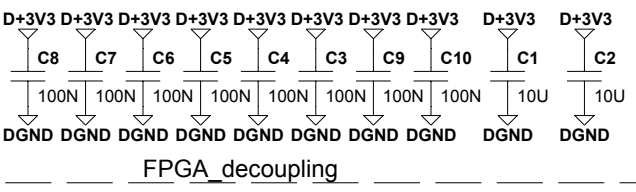
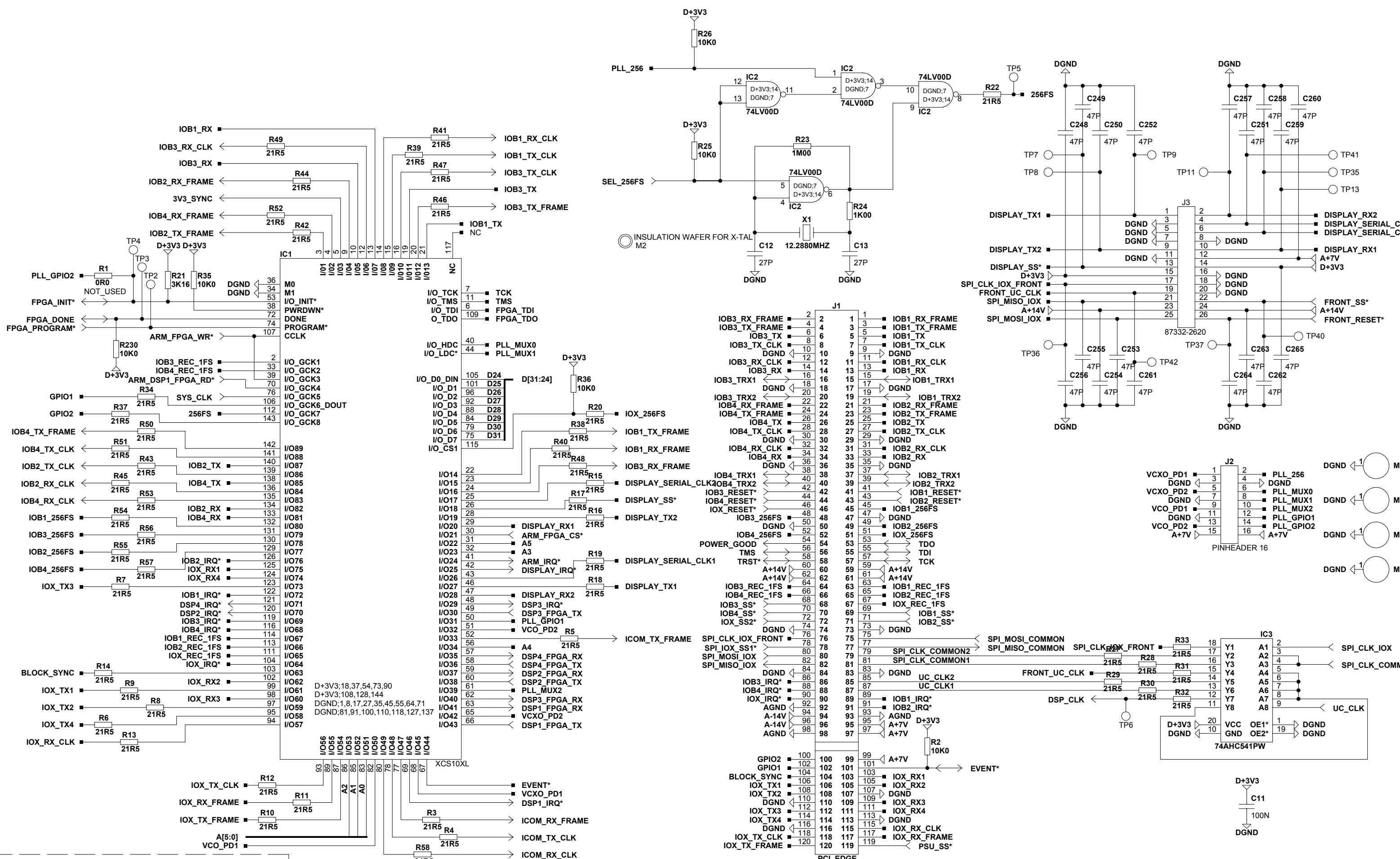

PKG_TYPE=PCI_PCB

TC Electronic A/S		Designer HK/MC
Title XWIZ HOST ETHERNET		Module title FPGA
Number P30301	Revision CAC	Previous page 1
Date 1-28-2004 15:14	Filename FPGA	Page / of 6 / 11

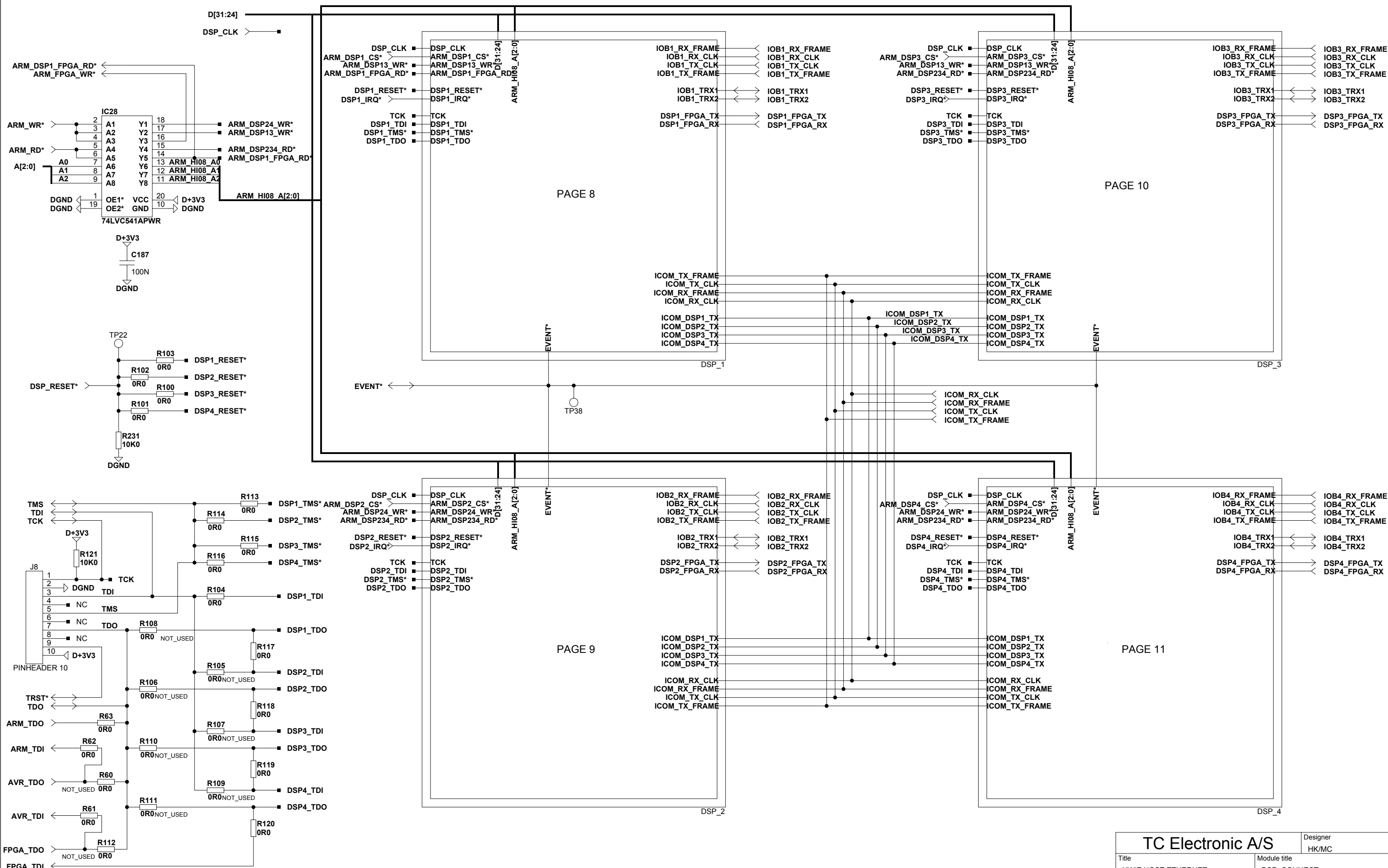

TC Electronic A/S		Designer HK/MC
Title XWIZ HOST ETHERNET		Module title DSP_CONNECT
Number P30301	Revision CAC	Previous page 1
Date 1-28-2004 15:16	Filename DSP_CONNECT	Page / of 7 / 11

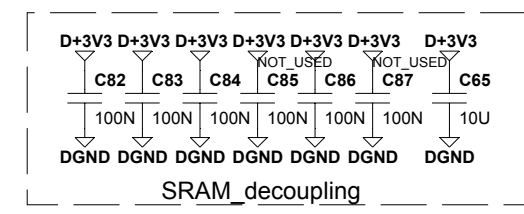
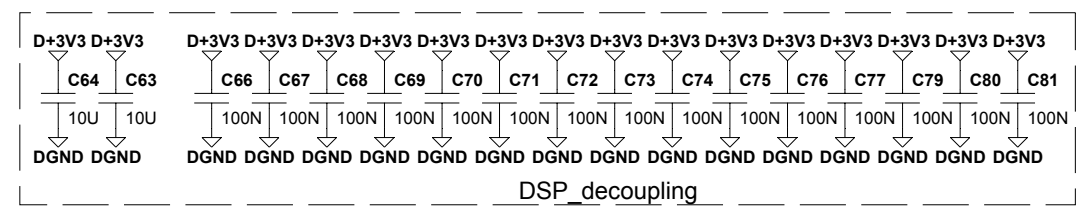
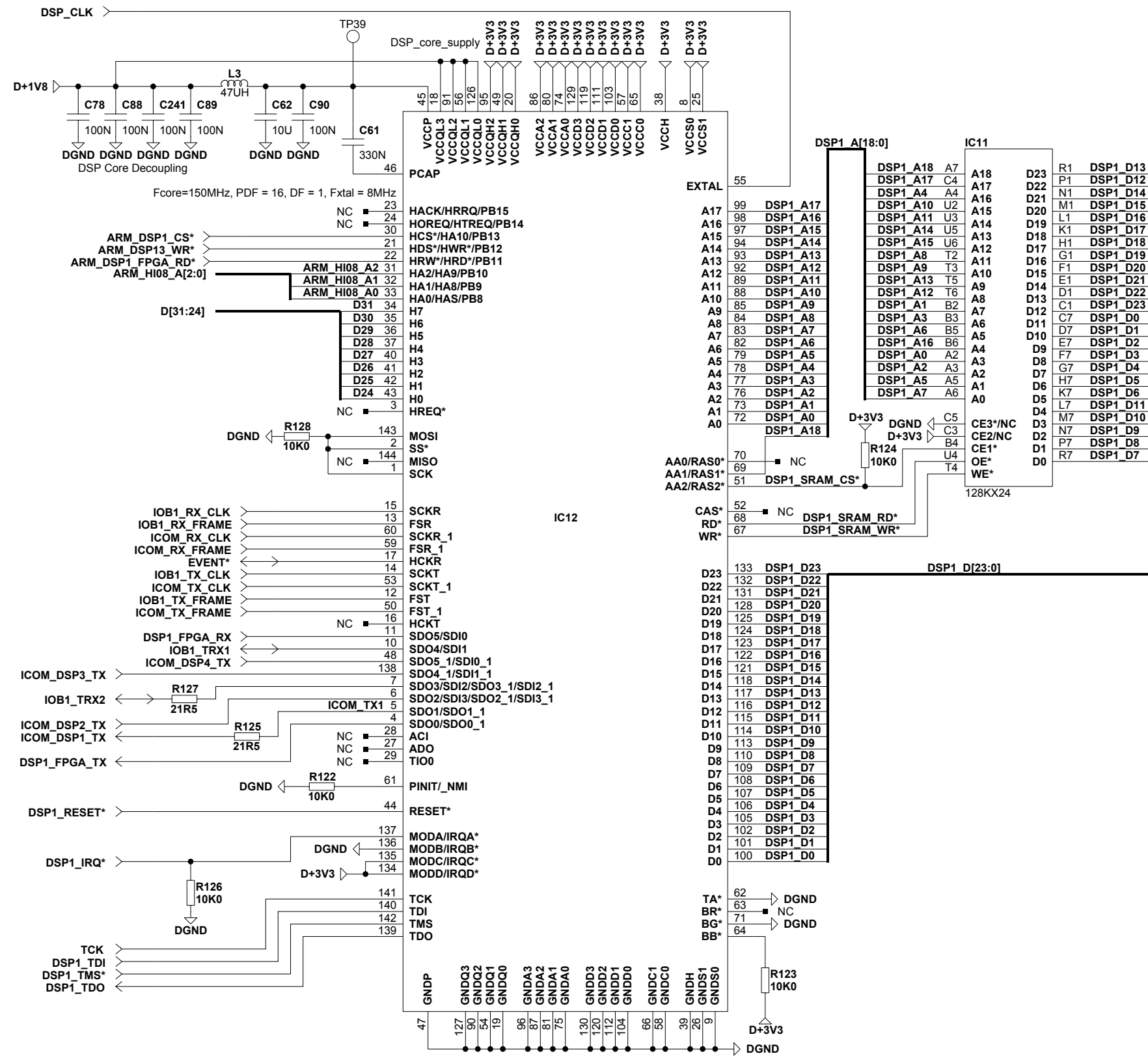

TC Electronic A/S		Designer HK/MC
Title XWIZ HOST ETHERNET	Module title DSP_1	
Number P30301	Revision CAC	Previous page 7
Date 2-23-2004 14:22	Filename DSP_1	Page / of 8 / 11

