

# VLS SERIES

Professional **loudspeakers**



# TANNOY®

Operation Manual

# Important Safety Instructions



The lightning flash with arrowhead symbol within an equilateral triangle, is intended to alert the user to the presence of uninsulated "dangerous voltage" within the product's enclosure that may be of sufficient magnitude to constitute a risk of electric shock to persons.

1. Read these instructions.
2. Keep these instructions
3. Heed all warnings.
4. Follow all instructions.
5. Clean only with a dry cloth.
6. Do not block any ventilation openings. Install in accordance with the manufacturer's instructions.
7. Do not install near any heat sources such as radiators, heat registers, stoves, or other apparatus (including amplifiers that produce heat.
8. Only use attachments/accessories specified by the manufacturer.
9. Use only with a cart, stand, tripod, bracket, or table specified by the manufacturer, or sold with the apparatus. When a cart is used, use caution when moving the cart/apparatus combination to avoid injury from tip-over.
10. Refer all servicing to qualified service personnel. Servicing is required when the apparatus has been damaged in anyway, does not operate normally, or has been dropped.



The exclamation point within an equilateral triangle is intended to alert the user to the presence of important operating and maintenance (servicing) instructions in the literature accompanying the product.

### **SAFETY WARNING**

Do not remove any covers, loosen any fixings or allow items to enter any aperture.

### **SAFETY WARNING**

Objects filled with liquids should not be placed on this apparatus.

### **AVERTISSEMENT DE SECURITE**

Ne retirez pas les couvercles, ne desserrez pas les fixations et ne laissez aucune pièce s'introduire dans les ouvertures.

### **AVERTISSEMENT DE SECURITE**

Ne placez pas d'objets contenant du liquide à proximité de l'appareil.

# Table of Contents

<b>2. Introduction</b> .....	<b>4</b>
<b>3. Unpacking</b> .....	<b>4</b>
<b>4. Selection of operating mode</b> .....	<b>5</b>
<b>5. Wiring and connections</b> .....	<b>6</b>
5.1 Connector type.....	6
5.2 Low-impedance mode.....	6
5.3 Constant voltage (70/100 V) mode.....	7
5.4 Wiring for outdoor applications.....	8
<b>6. Polarity checking</b> .....	<b>8</b>
<b>7. Equalisation</b> .....	<b>9</b>
<b>8. Mounting and flying</b> .....	<b>9</b>
8.1 Asymmetrical pattern considerations.....	9
8.2 Mounting and flying hardware.....	10
8.3 Rigging and safety procedures.....	11
<b>9. Outdoor applications</b> .....	<b>12</b>
<b>10. Technical specifications</b> .....	<b>13</b>
<b>11. Service parts and accessories</b> .....	<b>14</b>
<b>12. Warranty</b> .....	<b>14</b>
<b>13. Declaration of Conformity</b> .....	<b>15</b>

# 2. Introduction

The latest addition to Tannoy's extensive line of column loudspeakers, VLS Series introduces another proprietary Tannoy innovation: FAST™ (Focussed Asymmetrical Shaping Technology). By combining transducer technology from the acclaimed QFlex Series with an innovative new passive crossover design, FAST provides exceptional acoustical benefits, including an asymmetrical vertical dispersion pattern which gently shapes acoustical coverage toward the lower quadrant of the vertical axis.

The VLS Series comprises three models. The VLS 7 (7 × 3.5" LF) is designed for speech-only applications while VLS 15 (7 × 3.5" LF with 8 × 1" HF) and VLS 30 (14 × 3.5" LF and 16 × 1" HF) are designed for more demanding full-range music applications as well as speech. All are IP65 rated for dust and water ingress, are resistant to salt spray and UV, and have been subjected to rigorous high/low operational temperature and humidity testing. VLS Series loudspeakers are suitable for both indoor applications (house of worship, retail malls, auditoria) as well as covered outdoor use (transport hubs, concourses). Easy mounting is facilitated via supplied wall and flying brackets, with an optional pan-tilt bracket available.

Aided by an addition of an exclusive Tannoy edition of EASE Focus v2.0 software, consultants can design systems with predictable results and also specify VLS Series in conjunction with Tannoy's existing column loudspeakers – including I Series and QFlex – within the familiar environs of an industry standard software wizard.

VLS Series loudspeakers can easily be switched from low-impedance mode (6 ohms for VLS 30, 12 ohms for VLS 7 and VLS 15) to 70/100 V distributed line operation. For quick and simple commissioning, this selection is made (along with the transformer tapping options) via a single rotary switch located on the rear termination.

For applications requiring extended low frequency enhancement, a range of Tannoy sub-bass systems are available for use in conjunction with the VLS Series.

## 3. Unpacking

Each Tannoy VLS Series loudspeaker is carefully tested and inspected prior to shipment. After unpacking, please inspect for any exterior physical damage, and save the carton and any relevant packaging materials in case the loudspeaker again requires packing and shipping. In the event that damage has been sustained in transit, please notify your dealer and the shipping carrier immediately.

## 4. Selection of operating mode

All VLS Series models can be operated as either a low-impedance loudspeaker or within a 70/100 V distributed system. The operation mode is selectable via a single switch located on the rear of the cabinet.

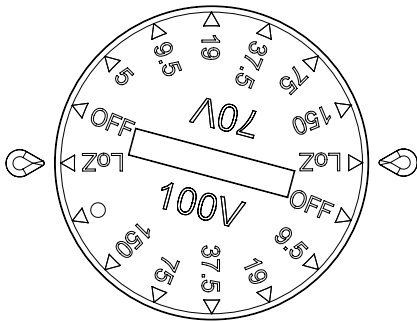

Low-impedance mode is recommended if the cable runs are relatively short and the number of speakers is small. If, on the other hand, the cable runs are long and more than a few loudspeakers are required, then a distributed line system is ideal.

When operating in low-impedance mode, the loudspeaker is able to deliver a wider frequency and dynamic range. However, if the cable runs are excessively long, then the sound quality may be compromised due to the increase in cable resistance and the resulting power losses. To keep the load to the amplifier manageable, it is also recommended that a small number of speakers be used, thus avoiding complex series/parallel combinations.

When a large number of speakers are installed over long cable runs, it is recommended that a distributed (70/100 V) system be used. For distributed line, the cable need not have as large a cross sectional area as for low-impedance, resulting in savings in cable cost. All speakers are placed in parallel with the output of the amplifier, allowing easy installation. The wattage tapings can be individually adjusted, giving more flexibility within an installation.

# 5. Wiring and connections

## 5.1 Connector type

Each VLS Series loudspeaker is equipped with a pair of internally paralleled barrier strip terminals for connection to the amplifier (or to other loudspeakers in a 70/100 V system or series/parallel configuration). Barrier strips accept wire up to 4 mm sq CSA (AWG 12). Barrier strip polarity is as indicated.

## 5.2 Low-impedance mode

If connecting directly to the amplifier in low-impedance mode, connect the positive (+) conductor to a positive (+) barrier strip terminal and the negative (-) conductor to a negative (-) terminal. Several loudspeakers may be connected to one amplifier output in parallel, series, or series/parallel configurations using the other internally paralleled barrier strip connector. Please refer to following section on series/parallel configuration before connecting.

When choosing cable type, it is important to select the correct cross sectional area in relation to the cable length and the load impedance. A small cross sectional area will increase the cable's series resistance, inducing power loss and response variations (damping factor). Connectors wired with 2.5 sq. mm (12 AWG) cable will be satisfactory under normal conditions; with very long cable runs, the wire size should be increased. Please refer to the following table for guidance:

Cable Run (m)	C.S.A.of each conductor (mm <sup>2</sup> )	AWG	Cable resistance ohms	% Power loss into 4 ohm load	dB loss into 4 ohm load	% Power loss into 8 ohm load	dB loss into 4 ohm load
10	2.5	13	0.13	3.9	0.17	2.0	0.09
	4	11	0.08	2.5	0.11	1.3	0.06
	6	9	0.05	1.6	0.07	0.8	0.04
25	2.5	13	0.33	9.3	0.42	4.9	0.22
	4	11	0.21	6.1	0.27	3.1	0.14
	6	9	0.13	3.9	0.17	2.0	0.09
50	2.5	13	0.66	17.0	0.81	9.3	0.42
	4	11	0.41	11.4	0.53	6.1	0.27
	6	9	0.26	7.5	0.34	3.9	0.17
100	2.5	13	1.31	29.1	1.49	17.0	0.81
	4	11	0.83	20.5	1.00	11.4	0.53
	6	9	0.52	14.0	0.65	7.5	0.34

**Amplifier selection** - As with all professional loudspeaker systems, the power handling is a function of voice coil thermal capacity. Care should be taken to avoid overdriving the amplifier into clipping. Damage to the loudspeaker will be sustained if the amplifier is driven into clipping for any extended period of time. Headroom of at least 3 dB should be allowed. When evaluating an amplifier, it is important to take into account its behaviour under low impedance load conditions. A loudspeaker system is highly reactive, and with transient signals it can require more current than the nominal impedance would indicate. Generally a higher power amplifier running free of distortion will do less damage to the loudspeaker than a lower power amplifier that is continually clipping. A high-powered amplifier running at less than 90% of output power generally sounds

superior to a lower power amplifier running at 100%. An amplifier with insufficient drive capability will not allow the full performance or the loudspeaker to be realised. (See technical specifications section for recommended amplifier power.)

When using amplifiers from different manufacturers in a single installation, make certain that all amplifiers have closely matched gains. (Variation should be less than +/- 0.5 dB.) This precaution is important to the overall system balance when only a single active crossover is being used with multiple cabinets. When possible, it is recommended that the same amplifiers be used throughout.

**Series/parallel connections** - When running low-impedance loudspeakers in parallel, care must be taken not to allow the impedance to drop too low, as damage may be sustained by the amplifier. Most low impedance amplifiers will be able to handle loads of 2 ohms to 8 ohms. This means for example that when using an amplifier with 2 ohm load rating, up to three VLS 30 or six VLS 7/15 may be connected in parallel per output, although care should be taken as impedance varies with frequency and at some frequencies the impedance will drop to below 2 ohms.

## 5.3 Constant voltage (70 /100 V) Mode

In constant voltage distributed systems, normally a number of loudspeakers are connected in parallel to a single amplifier output. Connect the positive (+) conductor from the amplifier or prior loudspeaker in the system to a positive (+) barrier strip terminal and the negative (-) conductor to a negative (-) terminal. The other parallel barrier strip is available for connecting additional loudspeakers.

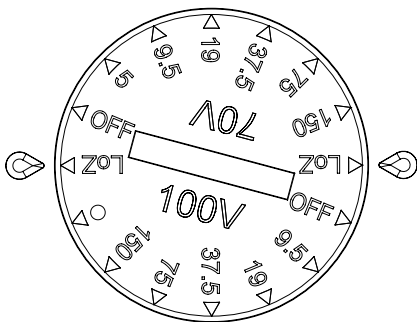

A multi-position rotary switch on the rear input panel selects either the low-impedance operating mode or the high-impedance modes (70 V or 100 V) with available transformer taps. When using VLS Series loudspeakers in distributed line systems, the transformer can be tapped with available power levels shown in the table below:

70 V	100 V
5 W	9.5 W
9.5 W	19 W
19 W	37.5 W
37.5 W	75 W
75 W	150 W
150 W	-

## 6. Polarity checking

All transformer primaries should be connected in parallel to the output of the amplifier. The summed total power rating in watts of the selected tap settings for all connected loudspeakers must not exceed the total output power rating of the connected amplifier output channel in watts. It is recommended that a generous power safety margin (minimum 3 dB headroom) be maintained between the total loudspeaker power requirements and the amplifier output capacity to avoid continuous amplifier operation at full rated output.

### 5.4 Wiring for outdoor applications

An input panel cover with rubber wiring grommet is supplied for use in outdoor applications. Before making connections, pass the wire(s) through the rubber grommet. The input panel cover is secured to the cabinet using the four screws already inserted around the input.

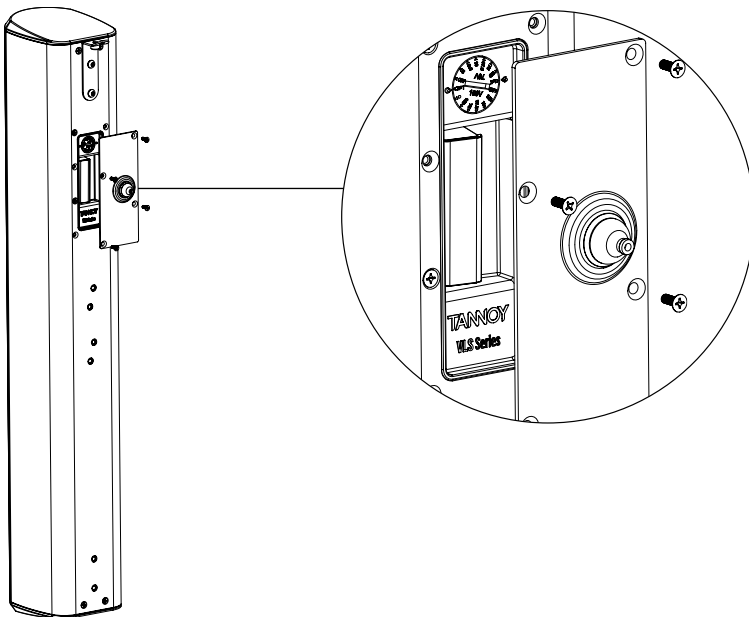

## 6. Polarity checking

Checking the polarity of the wiring before the speaker system is mounted or flown will help ensure satisfactory performance. If you do not have a pulse-based polarity checker, you may check LF units as follows: Connect two wires to the + and - terminals of a PP3 (9 V) battery. Apply the wire connected to the positive (+) terminal of the battery to the speaker cable leg which you believe to be connected the positive terminal of the speaker connector; likewise connect the negative (-) terminal of the battery to the negative terminal of the speaker. If you have wired it correctly, the LF drive unit will move forward. At this point, connect the positive (+) speaker lead to the + terminal on the amplifier and the negative (-) lead to the - terminal on the amplifier. However, if the LF driver moves backwards with the battery test, the input connections need to be inverted before connecting the amplifier. If problems are encountered, inspect the cable wiring. Note that different amplifier manufacturers may utilise different pin configurations and polarity conventions; if you are using amplifiers from more than one manufacturer, check the polarity at the amplifiers as well as at the loudspeakers.



## 7. Equalisation

VLS Series loudspeakers require no equalisation or correction to overcome system limitations; equalisation is necessary only to compensate for difficult acoustic environments. Over-equalisation can reduce system headroom and introduce phase distortion, resulting in degraded sound. If equalisation is required, it should be applied gently and smoothly. Because VLS Series loudspeakers are phase coherent designs, excessive equalization usually proves detrimental to the overall sound quality. When one loudspeaker is used in close proximity to another, comb filtering effects can create coverage problems. (Comb filtering creates an uneven frequency response across the coverage area due to constructive and destructive interference effects between the two sources.) Comb filtering cannot be cured by equalisation; this should be addressed with proper loudspeaker placement.

## 8. Mounting and flying

### 8.1 Asymmetrical pattern considerations

VLS Series loudspeakers are designed with an asymmetrical vertical dispersion pattern, a feature which allows improved performance with simplified mounting in many applications. The vertical dispersion of the VLS 7 and VLS 15 is  $+6 / -22$  degrees from center axis, while the pattern of the VLS 30 is  $+3 / -11$  degrees from center axis. Please be aware of this feature when planning your installation. In many situations where conventional column loudspeakers would require substantial downward tilt, a VLS Series loudspeaker would require less tilt or even allow flush mounting, thus providing a simpler installation with improved visual aesthetics.

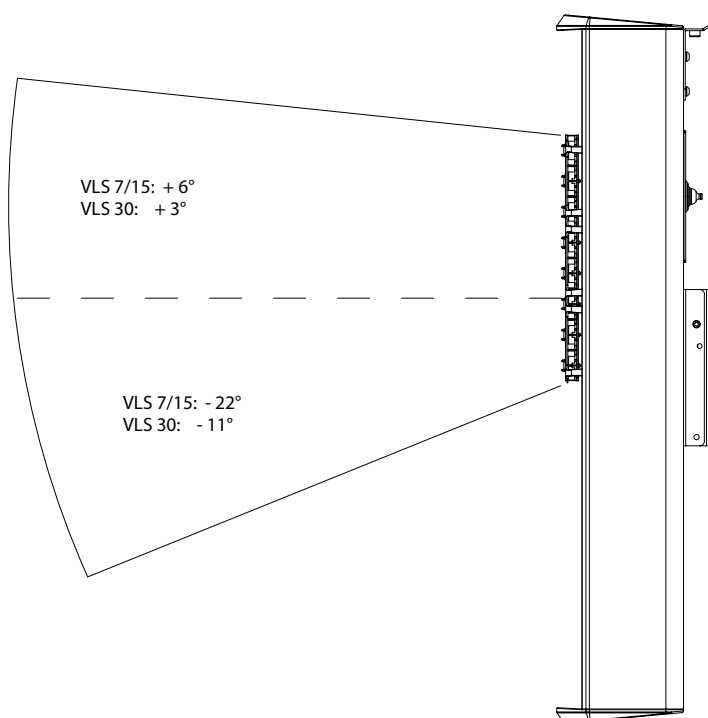

### 8.2 Mounting and flying hardware

**Wall Bracket** – Each VLS Series loudspeaker is supplied with a standard wall bracket suitable for mounting on most wall surfaces at either zero tilt or at an angle of 4 degrees. The bracket is supplied as two interlocking U plates. One plate attaches to the rear of the loudspeaker with four supplied screws and washers as shown. The other part is secured to the wall. The bar on the bottom of the speaker plate slides into the bottom notch of the wall plate, while the top is secured with the two supplied screws and washers. Aligning the top two screw holes results in a flat flush mount; using the lower two screw positions provides a 4 degree downward tilt.

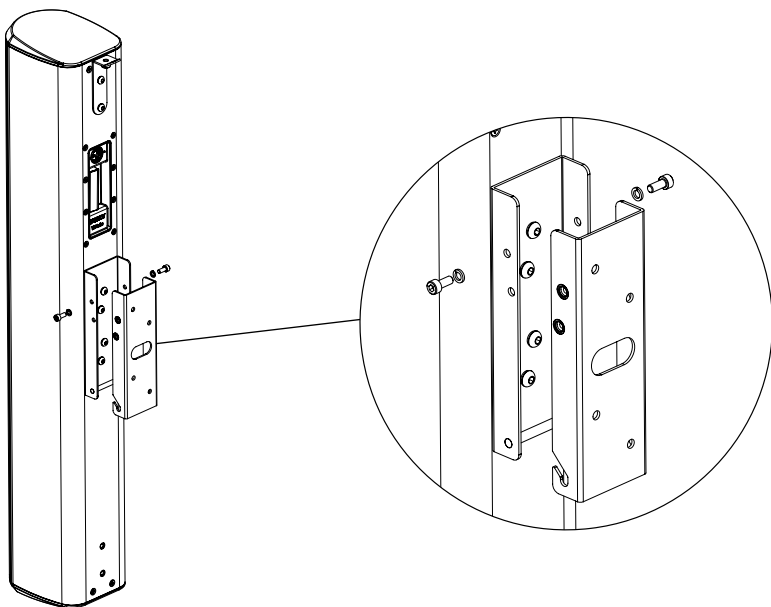

**Flying Bracket** – Each VLS Series loudspeaker is also supplied with a flying bracket. The bracket is attached to the top two inserts (see below) using the two supplied screws and washers. The two bottom inserts can be used as pull back if required.

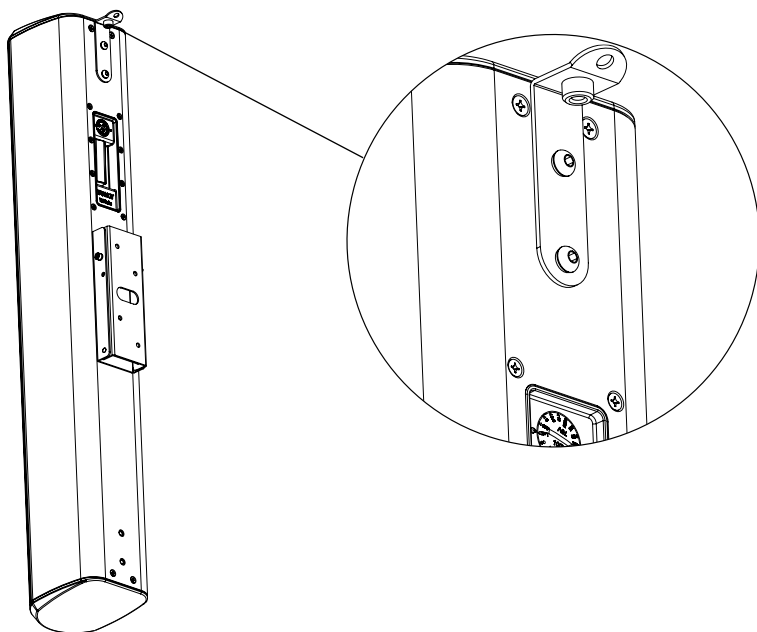

**Pan-Tilt Bracket (optional)** – A pan-tilt bracket is available which allows panning and tilting for flexible orientation along both horizontal and vertical axes. Detailed installation instructions are included with the pan-tilt bracket.

### 8.3 Rigging and safety procedures

**WARNING:** As the legal requirements for mounting, suspending, hanging, flying or rigging equipment change from country to country, please consult your local safety standards office before installing any product. We also recommend that you thoroughly check any laws and bylaws prior to installation.

The installation of Tannoy loudspeakers using the dedicated hardware should be carried out only by fully qualified installers in accordance with all the required safety codes and standards that are applied at the place of installation.

The Tannoy professional hardware covered in this guide has been designed to offer quick, simple, cost effective and secure solutions for mounting specific Tannoy professional loudspeakers. This hardware has been designed and manufactured with a high safety load factor for its specific role.

To ensure the safest possible use of the hardware covered in this guide, it must be assembled in strict accordance with the instructions specified. The information in these Operation Manuals relating to the assembly and the safe use of these accessories must be understood and followed.

Tannoy professional hardware has been designed for use with specific Tannoy professional loudspeakers, and is not designed or intended for use with any other Tannoy professional products, or any other devices. Using Tannoy professional hardware for any purpose other than that indicated in this guide is considered to be improper use. Such use can be very dangerous: overloading, modifying, damaging, or assembling in a manner other than that clearly stated in the operation will compromise safety. The component parts of any Tannoy professional hardware device must only be assembled using the accessory kits supplied and in strict compliance with the Operation Manual. The use of other accessories or non-approved methods of assembly may result in an unsafe hardware system by reducing the load safety factor.

Welding, or any other method of permanently fixing hardware components together or to the integral fixing points in the cabinet, should never be used.

Whenever a Tannoy professional loudspeaker is fixed to a surface using a Tannoy professional hardware device, the installer must ensure that the surface is capable of safely and securely supporting the load. The hardware employed must be safely and securely attached both to the loudspeaker and also to the surface in question, in accordance with the Operation Manual, using only the fixing holes provided as standard and covered in the manual. Secure fixings to the building structure are vital. Seek help from architects, structural engineers or other specialists if in any doubt.

All loudspeakers flown in theatres, nightclubs, conference centres or other places of work and entertainment must be provided with an independent, correctly rated and securely attached secondary safety restraint in addition to the principal hardware device. This secondary safety restraint must prevent the loudspeaker from dropping more than 150 mm (6") should the principal hardware device fail.

# 9. Outdoor applications

VLS Series loudspeakers are rated IP65 for resistance to dust and moisture ingress, and are resistant to both salt spray and UV exposure, making them suitable for use in most outdoor applications. Please consult with your Tannoy dealer before installation in applications with extreme exposure to adverse environmental conditions such as prolonged heavy rainfall, prolonged temperature extremes, etc.

# 10. Technical specifications

	VLS 7	VLS 15	VLS 30
<b>Performance</b>			
<b>Frequency Response (-3 dB) <sup>1)</sup></b>	150 Hz - 11 kHz	150 Hz - 30 kHz	120 Hz - 22 kHz
<b>Frequency Range (-10 dB) <sup>1)</sup></b>	110 Hz - 14 kHz	110 Hz - 35 kHz	90 Hz - 35 kHz
<b>System Sensitivity (1 W @1 m) <sup>2)</sup></b>	90 dB	91 dB	94 dB
<b>Horizontal dispersion (-6 dB)</b>	130 degrees horizontal	130 degrees horizontal	130 degrees horizontal
<b>Vertical dispersion (-6 dB)</b>	+ 6 degrees / - 22 degrees (-8 degree bias)	+ 6 degrees / - 22 degrees (-8 degree bias)	+ 3 / - 11 degrees Vertical (-4 degrees bias)
<b>Driver complement</b>	7 x 3.5" (89 mm) full range drivers	7 x 3.5" (89 mm) woofers 8 x 1" (25 mm) metal dome tweeters	14 x 3.5" (89 mm) woofers 16 x 1" (25 mm) metal dome tweeters
<b>Crossover</b>	Passive network utilising Focussed Asymmetrical Shaping Technology (FAST)	Passive network utilising Focussed Asymmetrical Shaping Technology (FAST)	Passive network utilising Focussed Asymmetrical Shaping Technology (FAST)
<b>Directivity factor (Q)</b>	6.1 averaged 1 kHz to 10 kHz	9.1 averaged 1 kHz to 10 kHz	15 averaged 1 kHz to 10 kHz
<b>Directivity index (DI)</b>	7.9 averaged 1 kHz to 10 kHz	9.6 averaged 1 kHz to 10 kHz	11.8 averaged 1 kHz to 10 kHz
<b>Rated maximum SPL <sup>2)</sup></b>	112 dB (average), 118 dB (peak)	114 dB (average), 120 dB (peak)	120 dB (average), 126 dB (peak)
<b>Power handling</b>	150 W (average), 300 W (programme), 600 W (peak)	200 W (average), 400 W (programme), 800 W (peak)	400 W (average), 800 W (programme), 1600 W (peak)
<b>Recommended Amplifier Power</b>	450 W @ 8 ohms	600 W @ 8 ohms	1200 W @ 4 ohms
<b>Nominal Impedance</b>	12 ohms	12 ohms	6 ohms
<b>Construction</b>			
<b>Enclosure</b>	Aluminium extrusion	Aluminium extrusion	Aluminium extrusion
<b>Finish</b>	Ral 9003 (white) & Ral 9004 (black) Custom RAL finishes available (additional cost and lead-time)	Ral 9003 (white) & Ral 9004 (black) Custom RAL finishes available (additional cost and lead-time)	Ral 9003 (white) & Ral 9004 (black) Custom RAL finishes available (additional cost and lead-time)
<b>Connectors</b>	Barrier strip	Barrier strip	Barrier strip
<b>Fittings</b>	Flying bracket, wall mount bracket, input panel cover plate and gland	Flying bracket, wall mount bracket, input panel cover plate and gland	Flying bracket, wall mount bracket, input panel cover plate and gland
<b>Physical</b>			
<b>Dimensions</b>	W: 121 mm (4.8") H: 816.5 mm (32.1") D: 146 mm (5.7")	W: 121 mm (4.8") H: 816.5 mm (32.1") D: 146 mm (5.7")	W: 121 mm (4.8") H: 1460.5 (57.5") D: 146 mm (5.7")
<b>Packed quantity</b>	1	1	1
<b>Net weight</b>	10.4 kg (22.9 lbs)	11.3 kg (24.9 lbs)	20 kg (44 lbs)
<b>Shipped weight</b>	13 kg (28.7 lbs)	14 kg (30.9 lbs)	23 kg (50.7 lbs)

(1) Average over stated bandwidth. Measured at 1 metre on-axis.

(2) Unweighted pink noise input, measured at 1 metre in an anechoic chamber

A full range of measurements and performance data can be downloaded from [www.tannoy.com](http://www.tannoy.com). For project-specific system design assistance, contact our Applications Engineering and Training (AET) group via [www.aetgroup.tc](http://www.aetgroup.tc)

Tannoy operates a policy of continuous research and development. The introduction of new materials or manufacturing methods may introduce variances; however, performance will always equal or exceed the published specifications. All specifications are subject to change without notice. FAST is a trademark of Tannoy Limited. All other trademarks remain the property of their respective owners.

# 11. Service parts and accessories

Part number	Description
7900 1333	Driver kit - 0805 3.5" LF
7900 1334	Tweeter - 0305 1" HF

## 12. Warranty

### **No maintenance of the VLS Series loudspeakers is necessary.**

All Tannoy VLS Series professional loudspeaker products are covered by a 5 year warranty from the date of manufacture, subject to the absence of misuse, overload or accidental damage. Claims will not be considered if the serial number has been altered or removed. Work under warranty should only be carried out by a Tannoy Professional dealer or service agent. This warranty in no way affects your statutory rights. For further information please contact your dealer or distributor in your country. If you cannot locate your distributor please contact Customer Services, Tannoy Ltd at the address given below or check at [www.tannoy.com](http://www.tannoy.com).

Customer Services, Tannoy Ltd., Rosehall Industrial Estate, Coatbridge, Strathclyde, ML5 4TF, Scotland  
Telephone: 44 1236 420199  
Fax: +44 1236 428230  
E-Mail: [prosales@tannoy.com](mailto:prosales@tannoy.com)

**Please do not ship any product to Tannoy without previous authorisation.**

## 13 Declaration of conformity

The following apparatus is/are manufactured in the United Kingdom by Tannoy Ltd of Rosehall Industrial Estate, Coatbridge, Scotland, ML5 4TF and conform(s) to the protection requirements of the European Electromagnetic Compatibility Standards. The apparatus is designed and constructed such that electromagnetic disturbances generated do not exceed levels allowing radio and telecommunications equipment and other apparatus to operate as intended, and, the apparatus has an adequate level of intrinsic immunity to electromagnetic disturbance to enable operation as specified and intended.

<b>Details of the Apparatus:</b>	Tannoy contractor Loudspeaker
<b>Model Number:</b>	VLS SERIES
<b>Associated Technical File:</b>	EMCVLS SERIES
<b>Applicable Standards:</b>	EN 50081-1 Emission EN 50082-1 Immunity



Director of Engineering  
Tannoy  
04 April 2012

Tannoy (Direct UK)	T: 00 44 (0) 1236 420199	E: enquiries@tannoy.com
TCGI (ROW sales)	T: 00 45 8742 7000	E: info@tcgroup-international.com
TCGA (Americas sales)	T: 00 1 (519) 745 1158	E: info@tcgroup-americas.com
Tannoy Middle East	T: 00 971 (04) 4401208	E: enquiries@tannoy.com

Tannoy operates a policy of continuous research and development. The introduction of new materials or manufacturing methods will always equal or exceed the published specifications. All specifications are subject to change without notice. FAST is a trademark of Tannoy Limited. All other trademarks remain the property of their respective owners. Copyright (c) 2012 Tannoy Limited. All rights reserved.

[tannoy.com](http://tannoy.com)