

**TANNOY®**



## Owners Manual

**VNET 12, VNET 12 HP, VNET 15, VNET 300  
VNET 15 HL, VNET 15BP & VNET 18DR**

<b>1.0: IMPORTANT SAFETY INSTRUCTIONS</b>	
<b>2.0: INTRODUCTION</b>	
<b>3.0: THE BASICS</b>	3.1    Unpacking and visual checks
	3.2    Preliminary recommendation
<b>4.0: INTERFACE PANEL</b>	
<b>5.0: OPERATION</b>	5.1:    AC power requirements
	5.2    Cooling
	5.3    LED functions
	5.4    Limiters
	5.5    Audio Connections
	5.6    User DSP on/off
<b>6.0: NETWORK CONNECTIONS</b>	6.1    Linking cabinets
<b>7.0 SOFTWARE INSTALLATION</b>	
<b>8.0 SOFTWARE OPERATION</b>	8.1:    Updating firmware
<b>9.0: EQUALISATION</b>	
<b>10.0: ARRAYING</b>	
<b>11.0 DIMENSIONS</b>	
<b>12.0 PERFORMANCE DATA</b>	
<b>13.0: TECHNICAL SPECIFICATIONS</b>	
<b>14.0: RIGGING</b>	14.1 : SECUR ET - VMY yoke bracket
	14.2 : SECUR ET - V15Y & V12Y
	14.3 : SECUR ET - VMB wall mounting bracket
	14.4 : SECUR ET - VEB eyebolt
	14.5 : SECUR ET - VTH pole mount
	14.6 : SECUR ET - VCS ceiling saddle
	14.6 : SECUR ET - VPC pole clamp
<b>15.0: SERVICE PARTS &amp; ACCESSORIES</b>	
<b>16.0: WARRANTY</b>	
<b>17.0: DECLARATION OF CONFORMITY</b>	
<b>18.0: NOTES</b>	



The lightning flash with an arrowhead symbol within an equilateral triangle, is intended to alert the user to the presence of uninsulated "dangerous voltage" within the product's enclosure that may be of sufficient magnitude to constitute a risk of electric shock to persons.



The exclamation point within an equilateral triangle is intended to alert the user to the presence of important operating and maintenance (servicing) instructions in the literature accompanying the product.



### IMPORTANT SAFETY INSTRUCTIONS

- 1 Read these instructions.
- 2 Keep these instructions.
- 3 Heed all warnings.
- 4 Follow all instructions.
- 5 Do not use this apparatus near water.
- 6 Clean only with dry cloth.
- 7 Do not block any ventilation openings. Install in accordance with the manufacturer's instructions.
- 8 Do not install near any heat sources such as radiators, heat registers, stoves or other apparatus (including amplifiers) that produce heat.
- 9 Do not defeat the safety purpose of the polarized or grounding type plug. A polarized plug has two blades with one wider than the other. A grounding type plug has two blades and a third grounding prong. The wide blade or the third prong are provided for your safety. If the provided plug does not fit into your outlet, consult an electrician for replacement of the obsolete outlet.
- 10 Protect the power cord from being walked on or pinched particularly at plugs, convenience receptacles and the point where they exit from the apparatus.
- 11 Only use attachments / accessories specified by the manufacturer.
- 12 Use only with the cart, tripod, bracket or table specified by the manufacturer, or sold with the apparatus. When a cart is used, use caution when moving the cart / apparatus combination to avoid injury from tip-over.
- 13 Unplug this apparatus during lightening storms or when unused for long periods of time.
- 14 Refer all servicing to qualified service personnel. Service is required when the apparatus has been damaged in any way, such as power-supply cord or plug damaged, liquid has been spilled or objects have fallen into the apparatus, this apparatus has been exposed to rain or moisture, does not operate normally, or has been dropped.

#### SAFETY WARNING

Permanent disconnection from the mains supply is to be achieved by removing the supplied cord connector from the back of the unit.

#### SAFETY WARNING

Do not remove any covers, loosen any fixings or allow items to enter any aperture.

#### SAFETY WARNING

Objects filled with liquids should not be placed on this apparatus.

#### SAFETY WARNING

Replace the mains fuse only with the same T10A HBC type supplied by Tannoy under part number 34610919

#### SAFETY WARNING

The rear heatsink on this product gets hot. Avoid direct skin contact during operation and for at least 5 minutes after power has been isolated.

#### AVERTISSEMENT DE SECURITE

Pour déconnecter l'appareil de l'alimentation principale de façon permanente, débranchez le connecteur du câble fourni à l'arrière de l'appareil.

#### AVERTISSEMENT DE SECURITE

Ne retirez pas les couvercles, ne desserrez pas les fixations et ne laissez aucune pièce s'introduire dans les ouvertures.

#### AVERTISSEMENT DE SECURITE

Ne placez pas d'objets contenant du liquide à proximité de l'appareil.

#### AVERTISSEMENT DE SECURITE

Ne remplacez le fusible de réseau principal que par un fusible T10A HBC du même type fourni par Tannoy sous la référence 34610919.

#### AVERTISSEMENT DE SECURITE

Le radiateur arrière de cet appareil devient chaud. Evitez tout contact direct avec la peau pendant le fonctionnement et au moins 5 minutes après la mise hors tension de l'appareil.

## INSTALLATION INSTRUCTIONS

- 1 THIS PRODUCT MUST BE EARTHED. Use only a flexible cable or cord provided with a green or green and yellow core which must be connected to the protective earthing terminal of the detachable Neutrik 'Powercon' type NEC3FCA connector (Tannoy part number 3461 0919 as supplied with the equipment. The other end of the green or green and yellow conductor must be connected to the earthing pin of a suitable mains plug or the earthing terminal of the installation. The cord must be of maximum length 7.5 meters, rated SJ, SJT, or SJE, 10A minimum and be marked VW-1.
- 2 The electrical power connection to this product is only to be made via a detachable Neutrik 'Powercon' type NEC3FCA connector (Tannoy part number 3461 0919) as supplied with the equipment. Wiring to this connector must only be made by suitably qualified personnel and must comply with all local requirements.
- 3 Do not install this equipment in an enclosed space. Do not limit free ventilation and movement of air around the back panel. Ensure that there is at least 100mm (4") of space around all sides of the product for ventilation.
- 4 Only use attachments and accessories approved by or specified by Tannoy.

## FOR CUSTOMERS IN EUROPE

This product complies with both the LVD (electrical safety) 73/23/EEC and EMC (electromagnetic compatibility) 89/336/EEC directives issued by the commission of the European community.

Compliance with these directives implies conformity with the following European standards:

EN60065	Product safety
EN55103-1	EMC emissions
EN55103-2	EMC immunity

This product is intended for the following electromagnetic environments: E2; E3 & E4. Environment E1 (domestic) is specifically excluded.

## FOR CUSTOMERS IN THE USA & CANADA

This product has been tested for electrical safety and complies with:

UL60065 7th edition  
CA /CSA C22.2 No.60065-03

## EMC

This equipment has been designed to comply with the limits for a Class A digital device, pursuant to part 15 of the FCC Rules. These limits are designed to provide reasonable protection against harmful interference when the equipment is operated in a commercial environment.

Industry Canada Class A emission compliance statement: This Class B digital apparatus complies with Canadian ICES-003. Avis de conformité à la réglementation d'Industrie Canada. Cet appareil numérique de classe A est conforme à la norme ICES-003.

## 2.0: INTRODUCTION

Tannoy has integrated the Dual Concentric™ point source, constant directivity drive unit with leading edge digital signal processing, network control and class D amplifier technologies to create **VNET™**. High definition sound reinforcement (HDSR™) loudspeakers designed to form the complete installation solution. Close integration and proximity of the main system elements has many advantages, and permits the amplifiers, processing, monitoring and drivers to perform as a unified whole. The resulting package is a very high performance loudspeaker with intuitive user setup, integrated processing, tuning control, performance diagnostics and protection. Class D power amplification with a switched mode power supply is very efficient, flexible and reliable. Little is required in the way of heat sinking and no fans are required. The small control panel on the rear of the cabinet is all the surface area that is needed for cooling, allowing the unit to operate at a low temperature, even when driven at very high power levels. The digital electronics (DSP) also use switched mode regulators to further improve efficiency and enhance design synchronicity of the entire package.

The Tannoy **VNet** Range of professional loudspeakers have been designed for a wide variety of sound reinforcement applications requiring extended frequency response from a powerful yet compact system, capable of delivering high sound pressure levels with extremely low distortion, resulting in outstanding clarity, definition and detail.

The Tannoy **VNET12** comprises one 12 inch Dual Concentric driver, in which the low frequency (LF) and high frequency (HF) sources are coincidentally aligned to a point source, resulting in a smooth uniform frequency response over a wide area of coverage either as a portable stand alone system or in a multi-cabinet array. The sophisticated CAD designed waveguide combines conical dispersion and excellent acoustic impedance characteristics. As the system is a point source, clusters and arrays have minimal lobing. These features are inherent and achieved without the use of any electronic signal processing.



The Tannoy **VNET12HP** & **VNET15** loudspeakers utilise high performance Dual Concentric™ drive units – the 12" (300mm) PowerDual™ and the 15" (380mm) PowerDual™. The substantially increased efficiency and power handling of these all-new driver designs ensures that the **VNET12HP** and **VNET15** are capable of delivering high SPL's in even the most demanding applications. Like all Tannoy Dual Concentric loudspeakers the Tannoy **VNET12HP** and **VNET15** exhibit true constant directivity, providing an even frequency response over the entire area of coverage. The output capability makes the Tannoy **V12HP** and **VNET15** loudspeakers suitable for much larger audience sizes or venues requiring very high SPL's, such as nightclubs.

The **VNET300** offers the ultimate in sound quality for critical applications such as theatre, acoustic music venues and houses of worship. For all applications where performance is the focus and the system should be so accurate that it reinforces, but remains unobtrusive and acoustically transparent to the audience, the **VNET300** is the natural choice. The 12" SuperDual™ ensures the most even frequency response over a wide coverage area in the medium size venues for which the Tannoy V300 is designed.

The asymmetric cabinet profile of the **VNet** Products allows flexible and discreet installation. As a foreground system, installation is made simple with a range of Secur-ET mounting hardware, designed specifically for the V series – or the system can be flown using the integral M10 inserts. For portable stage use the birch ply cabinet has a recessed carrying handle on the rear of the cabinet and a blanking plate, which can be removed to install an optional pole mount. As a versatile low profile stage monitor, the conical coverage pattern gives the performer greater freedom of movement than allowed by conventional horn loaded designs.

The loudspeakers are factory calibrated for optimum individual performance; this way the user does not have to worry about whether they have input the correct speaker management settings, or have to painstakingly optimise dynamics. They can concentrate on room measurement and optimisation alone. The product is shipped with our **VNET™** software package to facilitate easy on-site commissioning of the system. This intuitive Windows interface controls all of the critical install functions, as well as providing the interface for the ongoing monitoring of critical system status and performance data, all in real-time. Implementation of the network could not be simpler; **VNET™** will support 'Free Network Topology', using twisted pair cable & RJ45 connectors. Each loudspeaker will contain a unique address so no user input will be required to configure the network nodes. Each loudspeaker in the system can be individually optimized and acoustically profiled, taking into account its exact position within the venue relative to the room boundary, and its own performance relative to the acoustic properties of the room itself.

The Tannoy **VNET15BP** is a compact, versatile subwoofer system, primarily designed to extend the low frequency response of the V series loudspeakers and increase system headroom. The **VNET15BP** will extend the frequency response of these systems to below 40Hz and is capable of providing output levels normally be associated with considerably larger enclosures. The **VNET15BP** comprises one high efficiency 380mm(15") drive unit. The cabinet is constructed from multiple-ply hardwood, which will survive the punishment that speaker systems are subjected to on the road and in club installations. The compact dimensions of the **VNET15BP** enable it to be used in permanent or portable applications without being obtrusive.

The Tannoy **VNET15HL** is a horn-loaded subwoofer with very high output capability designed to provide maximum low frequency impact. The tight and "punchy" sound of the **VNET15HL** adds depth and dramatic impact for a wide variety of sound reinforcement applications. This powerful loudspeaker is capable of delivering remarkable sound pressure levels with extremely low levels of distortion and power compression, while maintaining a uniform frequency response throughout its dynamic range.

The **VNET15HL** comprises one high efficiency 380mm (15") drive unit. The cabinet is constructed from multiple-ply hardwood, which will survive the punishment that speaker systems are subjected to on the road and in club installations. The compact dimensions of the **VNET15HL** enable it to be used in permanent or portable applications without being obtrusive.

The Tannoy **VNET18DR** is a direct radiating subwoofer designed to compliment Tannoy **VNET** loudspeakers where high definition sound reinforcement at low/ultra low frequencies with increased headroom is required. The **VNET18DR** extends the frequency response of systems to below 30Hz, making it ideal for club, theatre and concert sound applications. This powerful loudspeaker is capable of delivering high sound pressure levels with extremely low distortion and power compression while maintaining a uniform frequency response throughout its dynamic range. The **VNET18DR** comprises one high efficiency 457mm(18") drive unit. The cabinet is constructed from multiple-ply hardwood, which will survive the punishment that speaker systems are subjected to on the road and in club installations.

**VNET** subwoofers feature recessed carrying handles and blank plate for a top-mounted stand socket, which serves as a base for locating the main full range or mid/high speakers in the air. By using 35mm tubing the need for a tripod stand can be eliminated.

### 3.0: UNPACKING AND VISUAL CHECKS

Every Tannoy **VNET™** product is carefully tested and inspected before being packaged and leaving the factory. After unpacking your loudspeaker, please inspect for any exterior physical damage, and save the carton and any relevant packaging materials in case the loudspeaker again requires packing and shipping. In the event that damage has been sustained in transit notify your dealer immediately.

### 3.1: PRELIMINARY RECOMMENDATION

A word of warning on high sound levels - these speakers are capable of generating high output levels over sustained periods of time and such levels, over 95dBspl for 8 hours per day, can eventually cause permanent hearing loss. Since Tannoy loudspeakers have a natural-sounding flat frequency response and low distortion, it's possible not to be aware just how high the sound level is high while working with them.

For continuous exposure we recommend the occasional use of a sound level meter. This should be capable of integrating the sound level over a period of exposure according to noise control standards and used just to check that noise levels are always within safety limits.

### 4.0: INTERFACE PANEL

#### Amplifier & DSP Panel

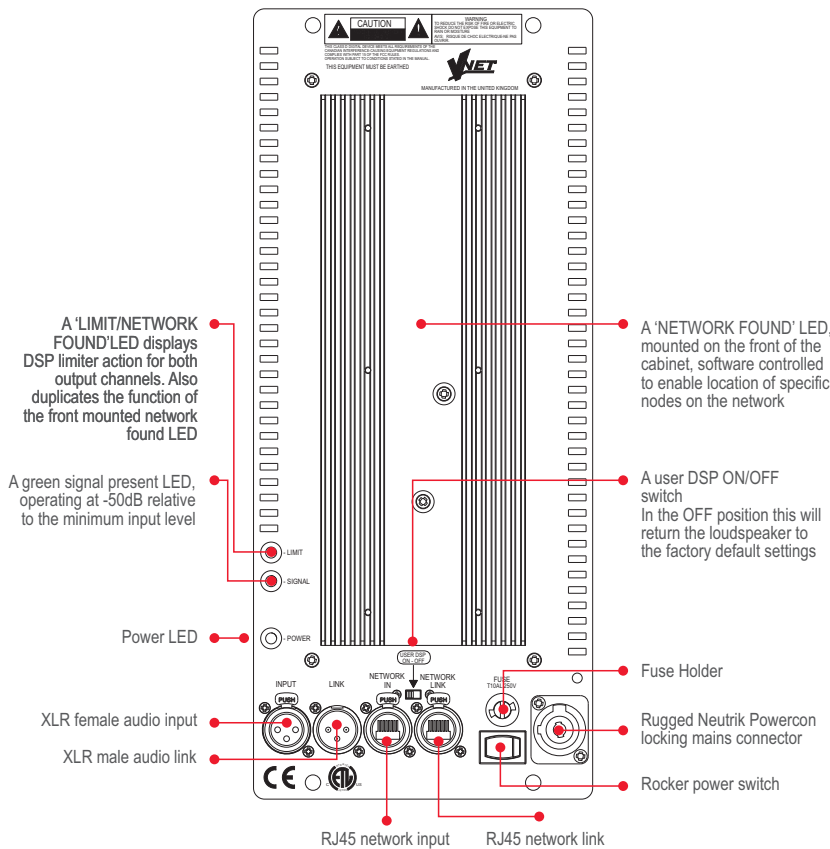

- XLR FEMALE AUDIO INPUT – This is a lockable XLR line input socket for connection to the audio source. Fully Balanced. Pin 2 Hot (+), Pin 3 Cold (+), & Pin 1 Ground.
- XLR MALE AUDIO LINK - This is a lockable XLR line output socket to link additional speakers. Fully Balanced. Pin 2 Hot (+), Pin 3 Cold (+), & Pin 1 Ground.
- RJ45 NETWORK INPUT - For Control and monitoring functions over RS485.
- RJ45 NETWORK LINK - For linking cabinets. Vnet supports free network topology. Cabinets can be 'daisy chained' or linked in a 'star' configuration, or a combination of both.
- ROCKER POWER SWITCH – Turns AC power on to the unit (100V – 240V)
- FUSE HOLDER – Replace only with 10A 230V anti-surge fuse. Tannoy part Number 3461 0919.
- AC MAINS CONNECOR – Neutrik Powercon mains connector (supplied)
- USER DSP ON/OFF SWITCH
- POWER LED – Blue LED indicates when power has been applied to the speaker.
- LIMIT/NETWORK FOUND LED – Also mounted on the front of the cabinet. This can be seen clearly from behind the grill when activated.
- SIGNAL PRESENT LED

### 5.0: OPERATION

The range of products are fully integrated designs, all speaker management functions which include driver EQ, dynamic limiting, & crossover functions are carried out within the DSP, therefore the need for external amplification, active crossovers and limiters is not required. The only input from the user is crossover between full range cabinets & subwoofers, and room equalization (if necessary).

When routing audio, units may be daisy chained together by linking the Input/link XLR connectors. It is necessary to have power local to each speaker, as it is not possible to daisy chain the AC power connectors.



## 5.1: AC POWER REQUIREMENTS

### AC Power Requirements

VNET™ products are equipped with Neutrik Powercon™ mains connectors which mate with the Neutrik NAC3FCA Cable connector, quick lock with a securing lever for power-in. This AC mains connector is supplied with each VNET™ product. The amplifier operates between the ranges of 100 to 240 Volts; the auto ranging power supply detects the mains voltage automatically and configures accordingly. Replace the mains fuse only with the same T10A HBC type supplied by Tannoy under part number 3461 0919.

## 5.2 COOLING

Do not install this equipment in an enclosed space. Do not limit free ventilation and movement of air around the back panel. Ensure that there is at least 100mm (4") of space around all sides of the product for ventilation. An efficient switch mode power supply has less weight, less current draw and more efficient mechanical cooling; meaning that no fans are required. In an area with a relatively high ambient temperature the heatsink can reach temperatures of up to 65 degrees C, this is perfectly normal.

## 5.3 LED FUNCTIONS

On switch on all of the LED's will illuminate instantaneously. The first to go off is the green signal LED after about 1 second. The red limit LED will flash for 5-10 seconds, this is the unit performing a self diagnostic test. During this initial few seconds the audio is muted until the red LED stops flashing & the blue power LED is the only LED left illuminated.

After the self diagnostic test is performed, the unit is ready to pass audio. When audio is detected the green signal LED will illuminate. If at any time the Red LED flashes this indicates that the DSP is taking corrective action by applying limiting to either the LF or HF channels (or both). Regular flickering of the Limit LED is perfectly acceptable; do not allow the limit LED to stay on constantly for any sustained length of time (reduce the gain).

Fast regular flashing of the red LED indicates that the DSP is taking protective action; the input will be automatically attenuated to avoid over driving, if this occurs the operator should reduce the input gain from the source. If the gain is not reduced the unit will eventually be shut down by the DSP.

The blue 'Network Find' LED on the front of the cabinet (behind the grill) can only be illuminated by activation from within the software interface. When activated the LED will flash intensely as an aid to locate and identify loudspeakers connected on the network. The red limit LED on the back panel also doubles as a 'network find' LED duplicating the function of the blue front mounted LED.

## 5.4 LIMITERS

The limiters are carefully set-up to preserve the loudspeakers dynamic headroom by allowing short term transients to pass; audible degradation in sound will only become apparent when the limit indication is on constantly. The limiting functions will protect the amplifier from long term overheating by attenuating the driving voltage to the drive units. If used irresponsibly (constant hard clipping) sound quality will be compromised. In extreme cases drive units may also be damaged.

## 5.5: AUDIO CONNECTIONS

### Audio Connections

The signal input & link connectors are fully balanced. When connecting a balanced signal be sure to wire to the following standard:-

SIGNAL	XLR CONNECTOR
Hot (+)	Pin 2
Cold (-)	Pin 3
Shield (GND)	Pin 1

In a standard balanced interconnection there are two signal conductors and a shield. The shield is normally referenced to ground at one or both ends. Many times the shield is lifted at one end, usually at the input to eliminate "ground loops" or noise. The problem with this approach is that while it may reduce hum, the shields act as radio antennas and pickup radio frequency interference from the environment.

Multiple enclosures may be driven from a single audio source; simply plug the signal source output into the first XLR input socket, and patch that speakers XLR link to the next speakers XLR input socket & so on.

## 5.6: USER DSP ON/OFF

A user DSP On/Off switch is provided on the amp panel. This miniature switch is recessed and can be easily activated with a small screwdriver.

The switch in the **'OFF'** position will return the **VNET™** loudspeaker back to the 'original' factory settings, this basically means that any parameter edited in software (EQ, Crossover, Mute, Delay) can be defeated by activating this switch. This can be a very useful feature. Example:-

In a large corporate production the networked loudspeakers are been used by an operator who has been using the Podware software for editing EQ & gain & delay; at the end of the performance he mutes the loudspeakers from within the software and the loudspeakers are returned to 'hire stock' after the performance. Next day there is a rush for a small hire comprising only a couple of **VNET™** loudspeakers. The speakers are taken to the small gig where the operator is not making use of the Networking, or Podware software in this particular instance. He realizes that he muted the loudspeakers the night before, and this particular pair had 100ms of delay applied!! All he has to do is flick the **USER DSP** switch to the **'OFF'** position (assuming he is carrying his Leatherman) and any of the **USER** editable parameters in Podware are defeated.

## 6.0: NETWORK CONNECTIONS

Interconnection between the network computer and the speakers is very straight forward, using twisted pair cable and simple connectors. The RS485 interface operates on a shared bus so that a single computer can control any amplifier on the bus, and the computer may gather status information from any device on the bus. Each module contains a unique address so that no user input will be required to configure network nodes.

It is only data that is carried over the network to control setup functions & ongoing system diagnostics, therefore if a network fault occurs, audio can still be delivered. This alleviates the problem of total system failure through a single system controller going down. As each loudspeaker controls it own DSP functions any unforeseen failure would be isolated to only that particular 'node'.

*example network*

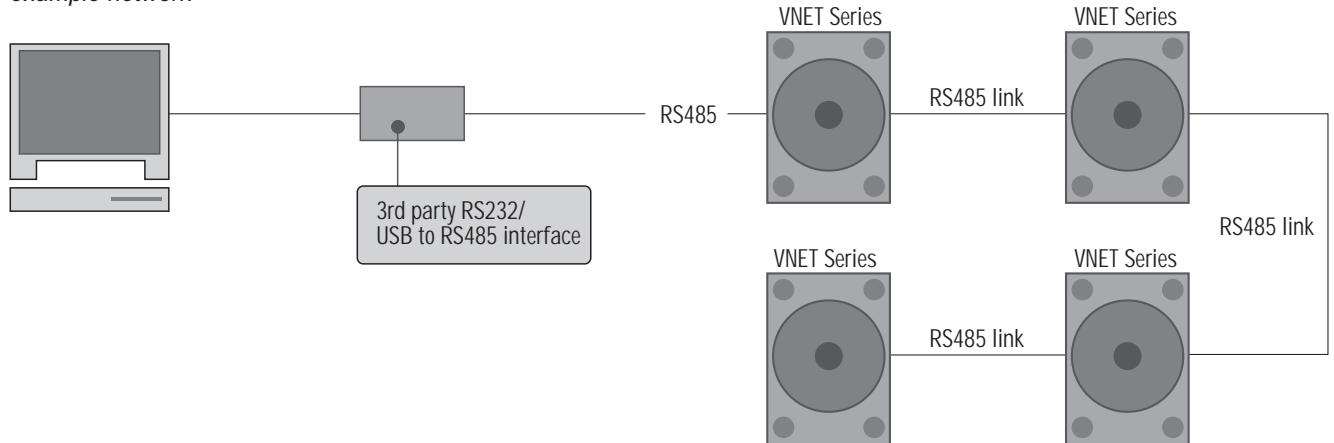

RS-485 is standard for sending serial data. It uses a pair of wires to send a differential signal over distances up to 4000 feet (1200m) without a repeater. The differential signal makes it very robust, RS-485 is one of the most popular communications methods used in industrial applications where it's noise immunity and long-distance capability are a perfect fit.

**IMPORTANT:** Always run a signal ground with RS-485

Connection from the PC to the network is via a 3<sup>rd</sup> party RS232 to RS485 or USB to RS485 interface. These devices are readily available from your IT supplier. At the time of writing this manual extensive testing was carried out with the following devices:-

Tannoy USB – RS485 Converter (Part No. 8001 3920)  
 K2 from KK ([www.kksystems.com](http://www.kksystems.com))  
 USB-COMi from Easysync ([www.easysync.co.uk](http://www.easysync.co.uk))  
 485 SD9R from B&B electronics ([www.bb-elec.com](http://www.bb-elec.com))





Connections from the RS485 device to the speaker is as follows:-

From RS485	Device RJ45 To Vnet Network
B+	Pin 1
A -	Pin 2
GND	Pin 5

Network connections between nodes are via rugged Neutrik 'ethercon' connectors; these are high quality and are compatible with standard RJ45 plugs. Node connections are made using standard RJ45 connectors and CAT5 cable. Long runs should be solid core, but standard is fine. The implication is that stranded is more robust and less prone to breakage, it is therefore suggested that solid should be used for install applications while stranded is better suited to rental applications. Cabinets can be 'daisy chained' or linked in a 'star' configuration, or a combination of both. Quality termination of all connectors at each node is essential for the network to function correctly.

## 6.1 LINKING CABINETS

The table below shows the standard 'straight-through' convention for CAT5 patch cables (clip down) . These can be used between network nodes. Bear in mind though that only Pins 1, 2, & 5 are used to link the network together.

P1 (pin No.)	V	P2 (pin No.)	Colour
1	V	1	White/Orange
2	V	2	Orange
3	V	3	White/Green
4	V	4	Blue
5	V	5	White/Blue
6	V	6	Green
7	V	7	White/Brown
8	V	8	Brown

To aid the construction of very large networks each speaker provides a source of power (+12Volts) on the network 'Link' connector that can be used to seamlessly power network extenders or repeaters that large networks may require. This power can be located on pin 4 on the 'NETWORK LINK' connector. This power is passed between the 'NETWORK IN' & 'NETWORK LINK' connectors if the speaker is powered off to ensure that upstream net powered devices continue to receive power.

## 7.0 SOFTWARE INSTALLATION

The enclosed disc contains the Podware software package; a comprehensive editor, interface, & diagnostics tool for the **VNET™** range of loudspeakers.

Check the Tannoy website for any updates <http://www.tannoy.com>

The disk should 'AUTORUN', if not open the 'Podware' folder & double click on the 'Setup.exe' icon.

Your PC will need to have the Windows .NET Framework installed. If it does not, you will be directed to the necessary location to do so [http://msdn.microsoft.com/netframework/downloads/framework1\\_1/](http://msdn.microsoft.com/netframework/downloads/framework1_1/)

The .NET Framework is also on your installation CD.

What is the .NET Framework?

The .NET Framework is an integral Windows component for building and running the next generation of software applications and Web services. The .NET Framework:

- Supports over 20 different programming languages.

- Manages much of the plumbing involved in developing software, enabling developers to focus on the core business logic code.

- Makes it easier than ever before to build, deploy, and administer secure, robust, and high-performing applications.

- The .NET Framework is composed of the common language runtime and a unified set of class libraries.

7.0 SOFTWARE INSTALLATION

You can check to see if you already have the .NET Framework 1.1 installed by clicking **Start** on your Windows desktop, selecting **Control Panel**, and then double-clicking the **Add or Remove Programs** icon. When that window appears, scroll through the list of applications. If you see Microsoft .NET Framework 1.1 listed, the latest version is already installed and you do not need to install it again.

Computer System Requirements:-

- Microsoft® Windows® 98
- Microsoft® Windows® 98 Second Edition
- Microsoft® Windows® Millennium Edition
- Microsoft® Windows NT® 4.0 Workstation with Service Pack 6.0a or later
- Microsoft® Windows NT® 4.0 Server with Service Pack 6.0a or later
- Microsoft® Windows® 2000 Professional
- Microsoft® Windows® 2000 Server
- Microsoft® Windows® 2000 Advanced Server
- Microsoft® Windows® 2000 Datacenter Server
- Microsoft® Windows® XP Home Edition
- Microsoft® Windows® XP Professional
- Microsoft® Windows® Server 2003 family

**Note** On all these systems, Microsoft® Internet Explorer 5.01 or later and Microsoft® Windows® Installer 2.0 or later are also required.

Hardware requirements:-

Scenario	Required processor	Recommended processor	Required RAM	Recommended RAM
Client (Windows Forms and Windows Services)	Pentium 90 MHz*	Pentium 90 MHz or faster	32 MB*	96 MB or higher
Server	Pentium 133 MHz*	Pentium 133 MHz or faster	128 MB*	256 MB or higher

\*Or the minimum required by the operating system, whichever is higher.

**Installing the software from the CD**

1. Exit all running programmes & insert the CD. Open the CD contents & Double click on the 'Setup.exe icon. The welcome screen will appear. Click **<Next>**

2. Select your destination Folder. Click **<Next>**

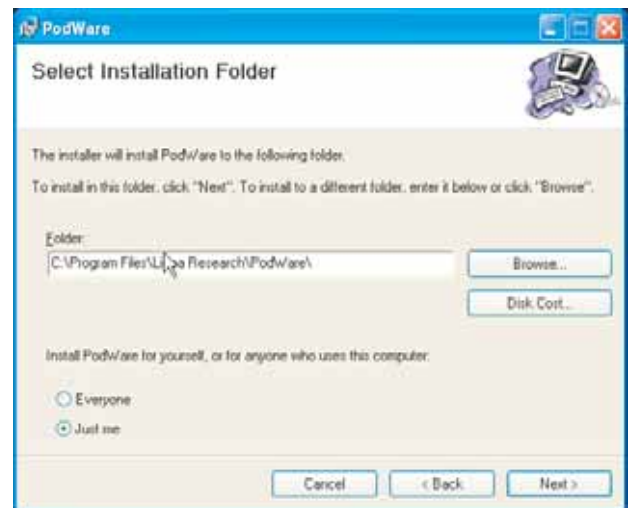



3. Confirm Installation. Click **<Next>**

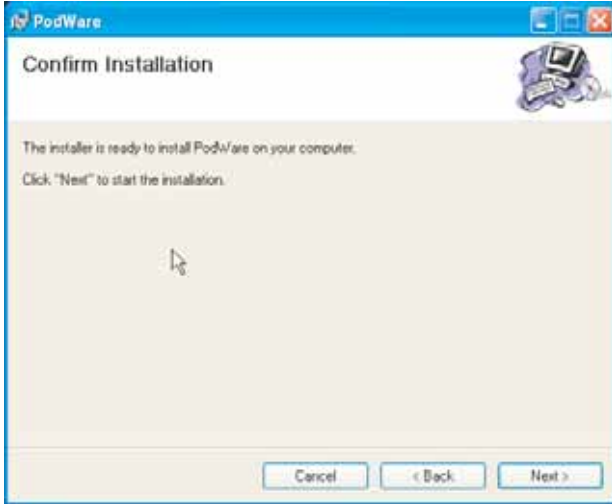

4. If you accept the licence agreement check 'I Agree' and Click **<Next>**

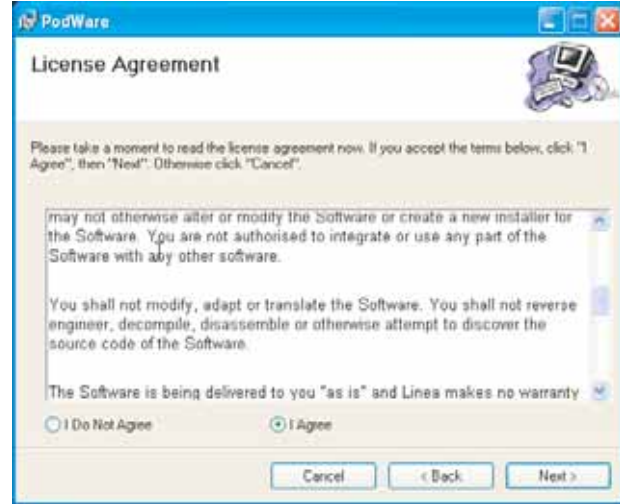

5. The programme will begin installing

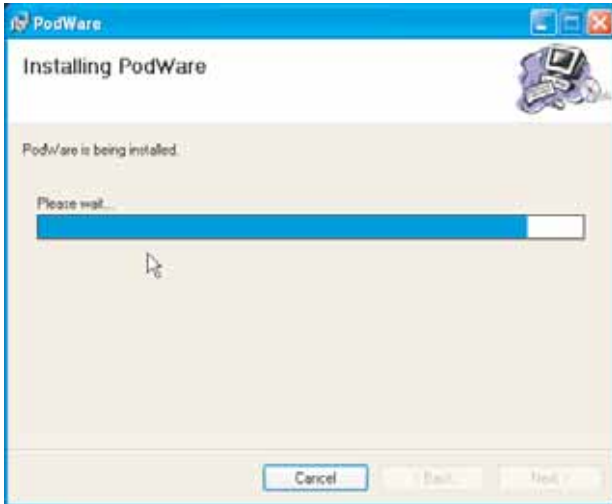

6. Installation Complete

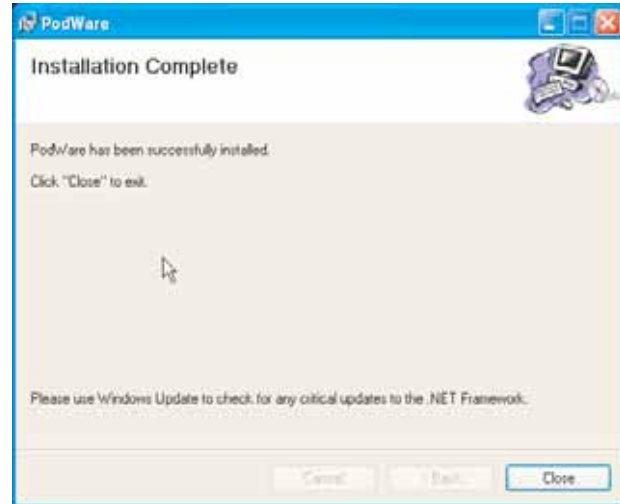

## Menus

The menu system is arranged like so:

### File

<b>Open</b>	opens a file which contains parameters for the device
<b>Save</b>	saves the current settings in the current file name
<b>Save As</b>	saves the current settings under a new file name
<b>Exit</b>	closes the application

### Device

<b>Update</b>	update device firmware (requires loader utility)
---------------	--

### Network

<b>Go Online</b>	allows communication with devices on the network
<b>Go Offline</b>	stops communication with devices on the network
<b>Port</b>	allows you to select which serial COM port you wish to use

### Help

**Help topics** - opens the help file (in your HTML viewer)

**About this Application** - shows copyright and version information

*Some of these menu items have short-cuts using toolbar buttons. See 'Toolbar'*

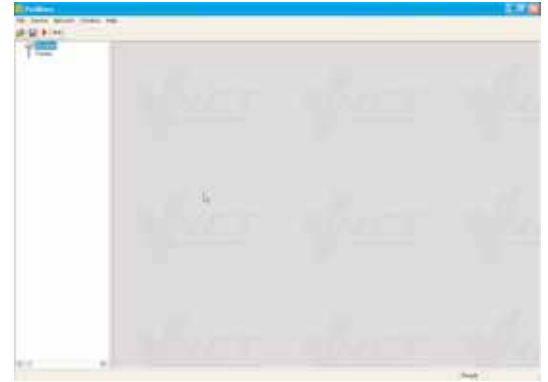

## Toolbar

The toolbar provides the following one-click functions:

<b>Open</b>	Opens a file which contains parameters for the device. A dialogue will appear, inviting you to choose a file to open.
<b>Save</b>	Saves the current settings. If you have previously opened or saved a file, the configuration will be saved in the same file name, otherwise, a dialogue will appear inviting you to enter a file name.  If the settings have not changed since you last saved or opened a file, the Icon will appear greyed out, indicating that a save is not necessary.
<b>Online</b>	Goes online/offline to/from the network. If a device cannot be found, an error will be reported. While PodWare remains on-line, this toolbar button is coloured green. It is red when off-line.
<b>Wink</b>	Flashes the indicators on the device (if online), to assist device identification, and as a quick check that communications are working. This only works when on-line.

If you place the mouse cursor over a toolbar, text fill appear describing the action of the button. If this text does not show, click on the panel background.

PodWare communicates with **VNET™** using a serial 'COM' port as a 'network' connection. When a network connection is open and actively connected to a compatible device, the system is said to be 'On Line'. Whilst On-line, you can control the connected device in 'real time', and continuously receive status information from the device. When going online, the application will take a few seconds while it copies the settings in the device to the control panel. (See **parameter synchronisation**)

To go On-line, you can either select Device/Online from the menu, or press the Online toolbar button, which is a red triangle. If all is well, the triangle will turn green, indicating that you are '**On-line**'.

You can however operate your system without going On-line. You can send the current controls settings to a device using Device/Send (See **Menus**), or by clicking the Send toolbar button (see **Toolbar**). These actions clearly still require a network connection to be present.

### Parameter Synchronisation

PodWare aims to always ensure that the control settings in the virtual control panel are always a faithful representation of the settings in the connected device. To achieve this, the parameters in the device are copied to the control panel when going online. This takes a few seconds to complete (see **Communications**). Whilst online, any changes to the control settings will result in changes in the stored parameters in the devices, thus retaining synchronisation. When a file is opened online, the new settings are not only set in the control panel; they are also transferred to the device.

### Controlling Devices

When 'online' the tree menu will show the connected **VNET™** speakers on the network. Double clicking on the model on the tree view will open the control panel for each respective device. Each 'open' panel will also appear on the tree view under 'panels'. When online, Podware gathers information from the connected devices. Any parameters which have been adjusted by the user in previous sessions will be shown.

Each control panel can be positioned on the screen to represent its actual location position in the venue. When saving data the control panels' co-ordinates are also saved so that it appears in the same location on the screen when data is recalled (see **saving & recalling data**)

The panels shown on the opposite screenshot allows you to view what is going on inside the **VNET™** product. As well as a mute button, there are limiter meters which indicate signal level relative to the limiter threshold setting, input level meter, clip indicators which show when an amplifier is clipping the signal due to overly high levels, driver status indicators showing the status of each driver ('A' is LF & 'B' is HF), a temperature meter showing the temperature of the amplifiers, and a 'Status' indicator showing when an amplifier is protecting itself from damage due to abnormal operating conditions.

The arrow button (>>) at the top right hand side of the control panel will 'expand' the control panel to reveal a host of parameters which can be viewed & adjusted.

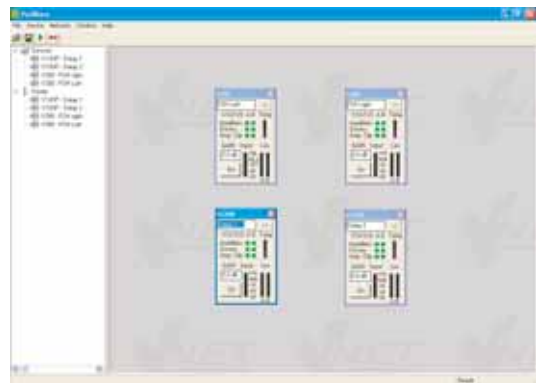
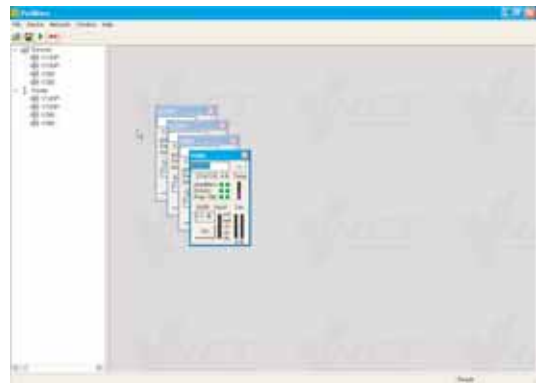
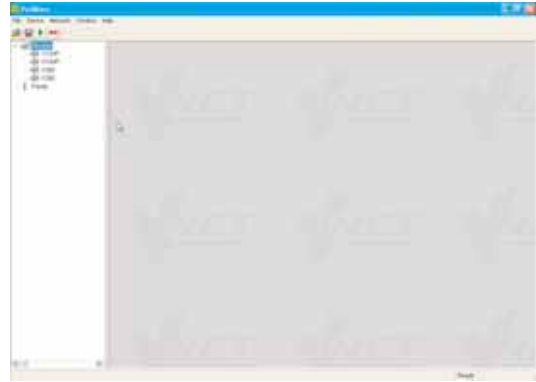

The control panel shows the model name (not editable), and firmware version for the device. The device properties panel also have an editable Configuration Name, and Loudspeaker name, the latter will appear in the tree menu after editing. Each panel will in addition have a complete set of controls relating to the adjustable parameters within the device (press the **EQ/DELAY** tab to access this section). Each control will contain the current parameter value (see **parameter synchronisation**). Single parameters may be adjusted 'live' whilst 'On-line'.

Controls have standardised properties that allow them to work in a consistent way across various control panels for different devices. Many controls will allow the mouse wheel to be used for fine adjustments, or the keyboard as an alternative (see Keyboard Shortcuts). When using the keyboard or the mouse wheel, it is necessary to have the control in question 'in focus'. You can bring a control into focus either by tabbing to it (using the Tab key), or by clicking on it with the mouse. Focus is often shown as a dotted rectangle around part of the control.

### Drop-Down Selector boxes

These are for selecting one item from a number of possibilities in a list. Click the arrow on the right-hand end of the control to cause it to display a list of the options. Click on the text for that option to select it. If there are many options to choose from, a scroll-bar will be shown, allowing you to scroll up and down the list by clicking the scroll arrows. Note that once the control is highlighted, the PGUP, PGDWN and Arrow keys or the mouse wheel may also be used to change the selection.

### Spin boxes

The value would normally be adjusted by clicking on the top button to increase the displayed value, or on the bottom button to reduce the displayed value. Holding the mouse button whilst on a button will after a short delay cause the repeat mechanism to repeatedly increment or decrement the value. Alternatively, values may be typed into the value box directly. To do this, click in the value box and type in the new value. The value you type in may include a minus sign, a decimal point, and/or an engineering multiplier, such as 'k' to signify a multiplication of 1000. This may appear at the end of the typed string, or may be used instead of a decimal point (such as 6k2 to mean 6200). For the value to be accepted, you can either click outside the control (such as on another control), or press the Enter key. Once a control button is highlighted, the PGUP, PGDWN and Arrow keys a mouse wheel may also be used to adjust the value.

### Buttons

Buttons generally have two states; depressed (active) and non-depressed (inactive). Generally, the button will apply the condition that is labelled when it is depressed. The space bar may be used to activate a highlighted button.

### Faders

Faders provide a linearly traversing button, which may be dragged using a pressed mouse to adjust the value. These sometimes also have an associated value box for showing the numerical value of the parameter. Once the control is highlighted, the PGUP and PGDWN keys may be used for coarse adjustment, and the Arrow keys or the mouse wheel may be used to for fine adjustment.

Also see (**VNET™ Control Panel**)

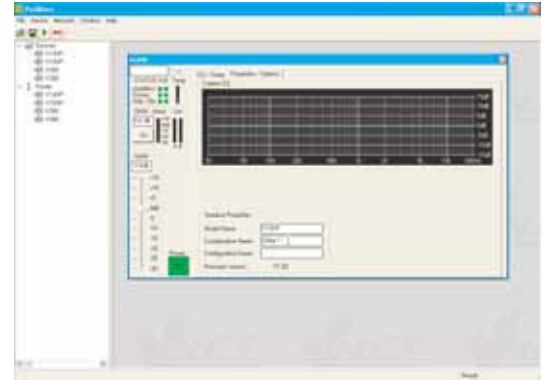



## VNET CONTROL PANEL

The control panel for **VNET™** allows **VNET™** parameters to be viewed and adjusted. The panel is organised into a monitoring area (at the top left of the panel) where the status of **VNET™** may be viewed, and a control area where all the controls to adjust parameters are located.

Note that Parameter adjustments are automatically stored in the DSP section of each **VNET™** - it is not possible to do temporary changes then store them separately.

Parameters which can be adjusted by the user are: Crossover/Delay, EQ (Equalisation), Gain & Power.

The Crossover/Delay tab allows you to adjust the crossover frequencies, crossover shapes & delays.

The EQ sections (8 bands) allow you to adjust the frequency and level (boost/cut) for each of the equalisation filters, and the bandwidth (Q) of the bell equalisers. The latter controls allow the responsiveness of the filters to be adjusted either as bandwidth (Octaves) or Q. The up/down buttons will change the values. Values may be typed into either the bandwidth or Q part of the box. A 'Frequency Response' curve shows the shape of each filter individually (by colour), and the combined effect of all equalisation (in white).

There are also High & Low shelving filters.

## SPEAKER PROPERTIES

At the top of the panel there are several pieces of information about the connected device (which are only activated when going On-line to a device):

### Model Name

The **VNET™** model number

### Loudspeaker name

To uniquely identify the speaker (i.e. delay 3)

### Configuration Name

A name of up to 12 characters that you may enter as a name for the current set of parameters.

### Firmware Version

A 4-digit hexadecimal number, acting as a 'signature' for the current set of parameters. This may be used as a quick check that the parameters loaded into an X-Pod are as they should be.

Also see *(Controls and Control Panels)*

## Keyboard Shortcuts

PodWare supports the following 'shortcuts':

Tab	Move to next control
In value boxes:	
CTL+C	Copy
CTL+V	Paste
CTL+X	Cut
CTL+Z	Undo
On Drop-down, Spin, Push, Fader controls:	
PgUp	Increase value (coarsely)
PgDown	Reduce value (coarsely)
Up/Right arrow	Increase value (finely)
Down/Left arrow	Reduce value (finely)
On push-button controls:	
Space	Activate

## Audio Processing

**VNET™ provides the following processing options:**

- Crossover filtering with frequency variable over the range 10Hz to 25kHz (and 'Out') with the following alignments:
  - 1<sup>st</sup> order
  - 12dB/Octave Bessel
  - 12dB/Octave Butterworth
  - 12dB/Octave Linkwitz-Riley
  - 18dB/Octave Bessel
  - 18dB/Octave Butterworth
  - 24dB/Octave Bessel
  - 24dB/Octave Butterworth
  - 24dB/Octave Linkwitz-Riley

The Low band has a low-pass crossover filter, and the High band has a high-pass and a low-pass crossover filter.

- A 2<sup>nd</sup> order low-shelf filter with frequency variable over the range 10Hz to 25kHz, and boost/cut from –15 to +15dB.
- A 2<sup>nd</sup> order high-shelf filter with frequency variable over the range 10Hz to 25kHz, and boost/cut from –15 to +15dB.
- Eight bands of bell (parametric) equaliser, each band having frequency variable over the range 10Hz to 25kHz, bandwidth variable from 0.1 to 5 octaves, and boost/cut from –15 to +15dB.
- Delay adjustable up to 200ms.
- Adjustable gain from –30 to +15dB, and mute.

### Equalisation Filters

The eight Bell filters (Parametric equalisation filters) may each be used to emphasise (by applying a positive Level parameter setting) or de-emphasising (by applying a negative Level parameter setting) a range of frequencies centred on the setting of the Frequency parameter, and encompassing a frequency range determined by the Bandwidth parameter setting.

The two shelving filters allow all frequencies below that of the frequency parameter (for the Low shelf) or all frequencies above that of the frequency parameter (for the high shelf) to be emphasised (by applying a positive Level parameter setting) or de-emphasised (by applying a negative Level parameter setting).

### Crossover shapes

In addition to the usual Butterworth, Linkwitz-Riley and Bessel filter shapes, **VNET™** processing provides access to Hardman crossover filtering. Hardman filters produce much steeper cut-off slopes for a given order than conventional crossover alignments, without any additional group delay. This allows a lower order filter to be used without sacrificing cut-off characteristics, but with smoother group delay and less severe phase penalties, giving a more natural sound. Hardman filters also provide identical phase characteristics between adjacent bands (like Linkwitz-Riley), so the polar performance is rock steady

We also employ phase matching on our Bessel filters, so adjacent bands are in-phase throughout the crossover region.

### Protection (factory optimised)

Comprehensive protection features preserve the longevity of the amplifier by continuously monitoring several critical parameters, and reducing the gain, or muting the amplifier either temporarily or permanently depending on the nature and seriousness of the fault or misuse. The amplifier will recover and restart if at all possible, but will remain shutdown if a serious fault persists (such as a permanent short circuit on the output).

Minor faults are dealt with by slowly 'dimming' the amplifier, reducing the level to a sufficient degree and for a sufficient time that the amplifier is able to recover gracefully without any user interaction. When the fault condition has passed, the amplifier will slowly fade up to normal.

More serious faults may cause the amplifier to mute while it recovers, after which it will automatically re-energise and fade up, again without user interaction. If such a fault is found to be persistent however, the amplifier is shut down permanently, flashing its limiter indicators rapidly in unison. A power cycle by the user is then required.

Any time the amplifier is being protected, the limiter indicator will flash rapidly.

During power-up, **VNET™** will keep the amplifier muted for a short time while checks are made that all is well. During this time, the Indicators will both be solidly on. The signal is then gently faded up, accompanied by rapidly flashing Indicators.



### Smooth adjustment

Whenever a parameter is changed, **VNET™** will assess the likely impact on the signal path, and will intelligently smoothly ramp to the new value, or mute for a short time if the change could otherwise cause any undesirable sound to be reproduced.

### Power ON & OFF

At the bottom left hand corner of the control panel there is a power button. Activating this button will shut down the amplifier. The DSP section remains active.

### Saving & Recalling Data

Device Data may be saved to disk or opened from disk.

PodWare Device Data files (with file extension .dse) contain all the data necessary to restore a device to exactly the same state as when the file was saved.

If the current settings have been changed since the last file save or file open, the Save Icon on the toolbar will be shown in solid colour. If the settings are already safe, the Save icon appears grey.

If a file is opened when on-line to devices, the new data will be sent to the device, overwriting whatever was in the device. A warning will be given before this is done.

Data saved from one device can be reopened in another to save time inputting data. (Assuming settings are to be duplicated)

Podware will always try to protect your data, warning you if you are attempting an action that could cause loss of data.

## 8.1: UPDATING FIRMWARE

Occasionally it may be necessary to update the devices firmware (with file extension .dfw); this may be due to added features or amendments to the **VNET™** product. Check with your dealer/distributor or ([www.tannoy.com](http://www.tannoy.com)) for any applicable updates.

Firmware can be updated over the network (no need to disconnect speakers from the network)

A firmware update will be common to all **VNET™** products (one file for all models).

Updating a devices firmware is straight forward:-

1. Download and save the new firmware file to disk.
2. From the toolbar select **'Device' & 'Start Firmware Loader'**
3. The following message will appear

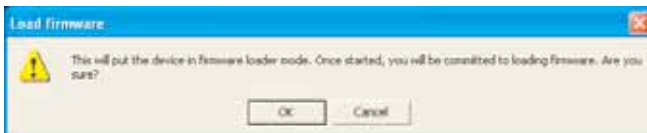

4. Click **'OK'**
5. Browse to the new firmware file & select. The following message will appear stating the old version number & the replacement version number.

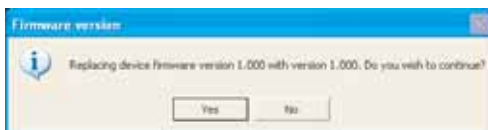

6. Click **'OK'**
7. In order for the new firmware to take effect the unit has to be switched off & back on again. This can be done automatically after the update. Click **'OK'** to confirm.

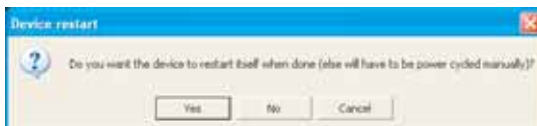

8. At the bottom right hand side of the screen a blue bar will show the progress of the firmware update.



9. After the download is complete the following message appears. The DSP is updating at this point. Do not power down the unit or disconnect any network cable at this point. During the update a red bar will show the progress of the firmware update (bottom right of screen).

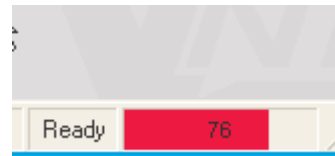

10. The device will then power cycle automatically. The loudspeaker is now ready for normal operation.

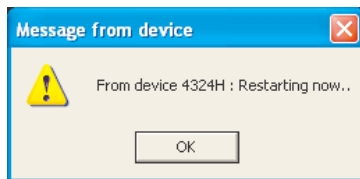

## 9.0: EQUALISATION

**VNET™** loudspeakers are designed to need no equalisation or correction to overcome system limitations. As a result, they will only need equalisation to compensate for difficult acoustic environments. Over equalisation can reduce system headroom, and introduce phase distortion resulting in greater problems than cures. If equalisation is required then it should be applied gently and smoothly. **VNET™** full range loudspeakers are point source, phase coherent designs and violent equalisation will be detrimental to the overall sound quality.

When a loudspeaker is used in close proximity to another, comb filtering effects can create coverage problems; comb filtering creates an uneven frequency response across the coverage area due to constructive and destructive interference effects between the sources. The amount of comb filtering is affected by the spacing of the relative sound sources. Minimising this effect cannot be cured by equalisation (see the following section for more details).



## 10.0: ARRAYING

As discussed in the previous section, comb filtering cannot be cured by equalisation. Small alterations to loudspeaker positions can have the effect of minimising problematic combing frequencies. Arrays should be constructed so that the individual coverage patterns of each loudspeaker combine with minimal overlap. The design of the **VNET™** cabinet greatly simplifies the creation of effective arrays, allowing seamless wide horizontal coverage (140deg for VNET12/VNET300 & 130deg for VNET12HP/V15) using two loudspeakers without the need for tedious experimentation.

By placing the VNET12, VNET12HP, & VNET300 cabinets with the 30 degree angled rear panels together, minimal dispersion pattern overlap is achieved, guaranteeing an extraordinarily smooth transition.

In many applications the 90-degree (75 – degree on the VNET12HP/V15) dispersion pattern may be sufficient in the horizontal plane.

It is also possible to stack the cabinets vertically using the above method, say for use in a central cluster, where greater vertical dispersion is required.

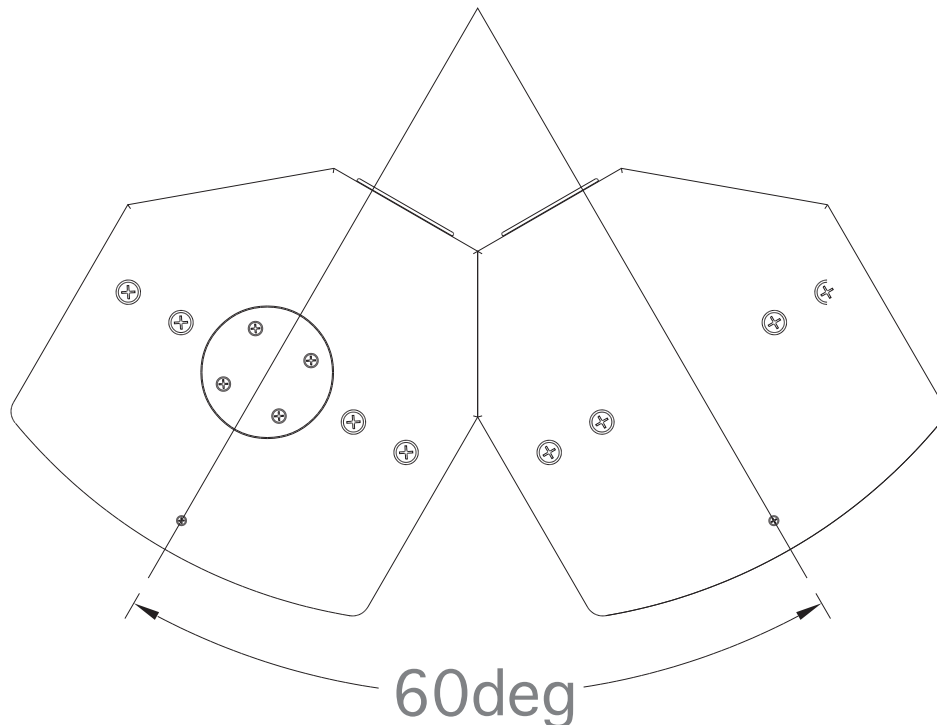

As shown in the above diagram, one of the **VNET™** cabinets is inverted to allow the optimum splay angle to be achieved. The grill can be simply removed from this cabinet and be replaced in the correct orientation. The grill is held in position by the two fixing screws on the top and bottom lips of the cabinet.

11.0 DIMENSIONS

VNET 12 & 12HP

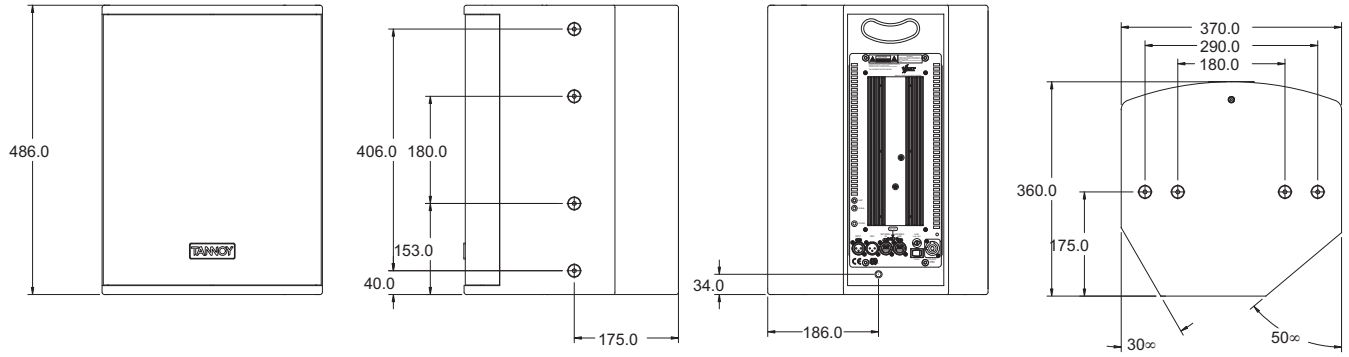

VNET 300

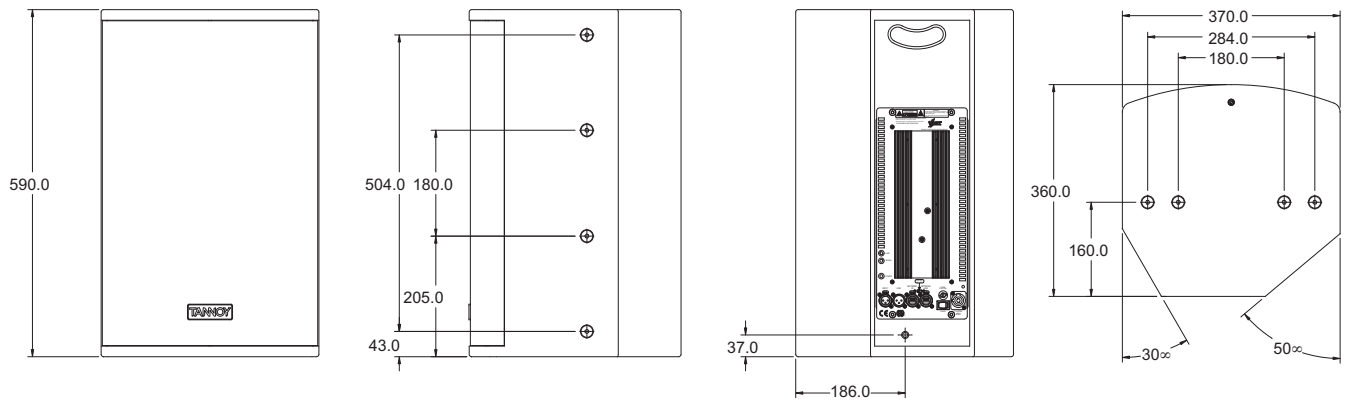

VNET 15

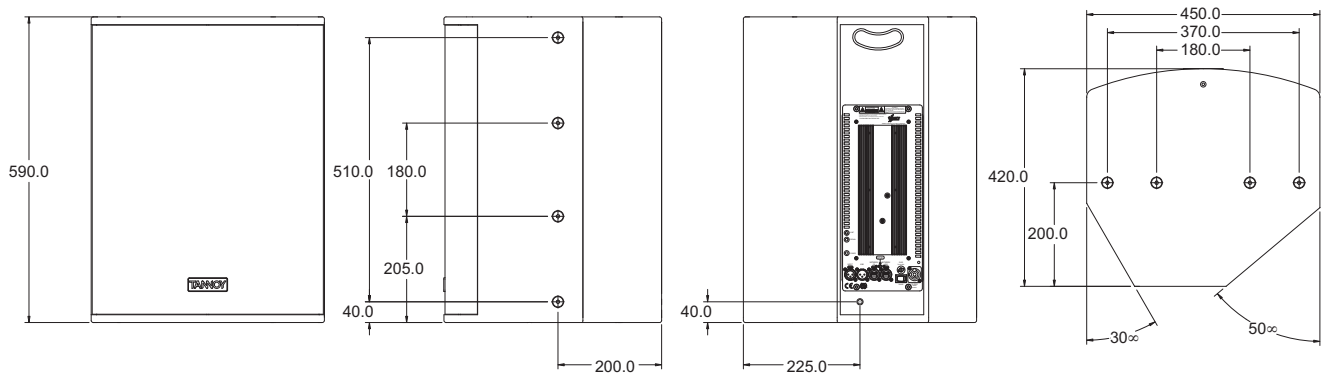



VNET 15 BP

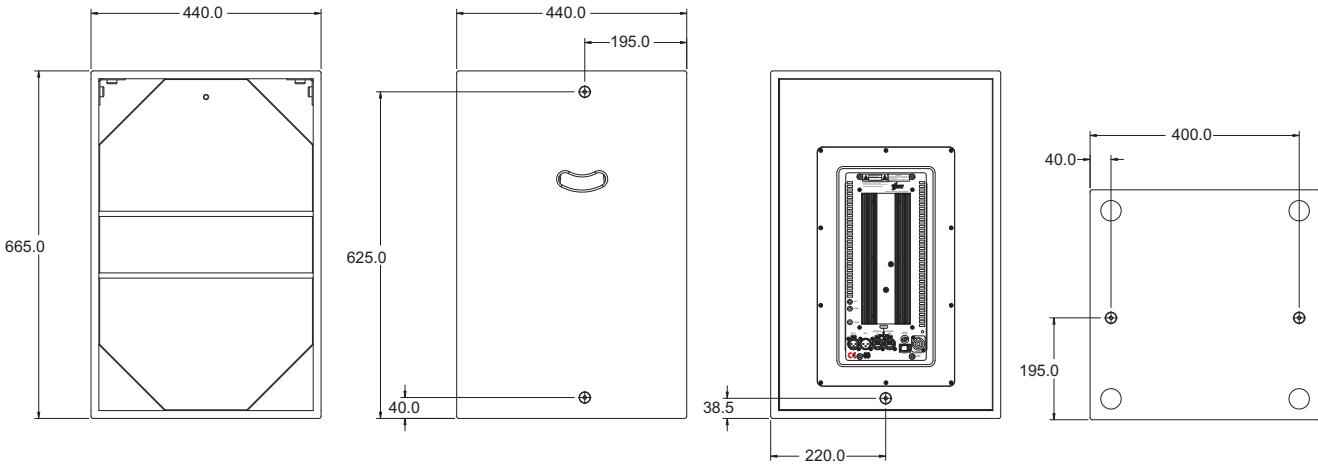

VNET 300

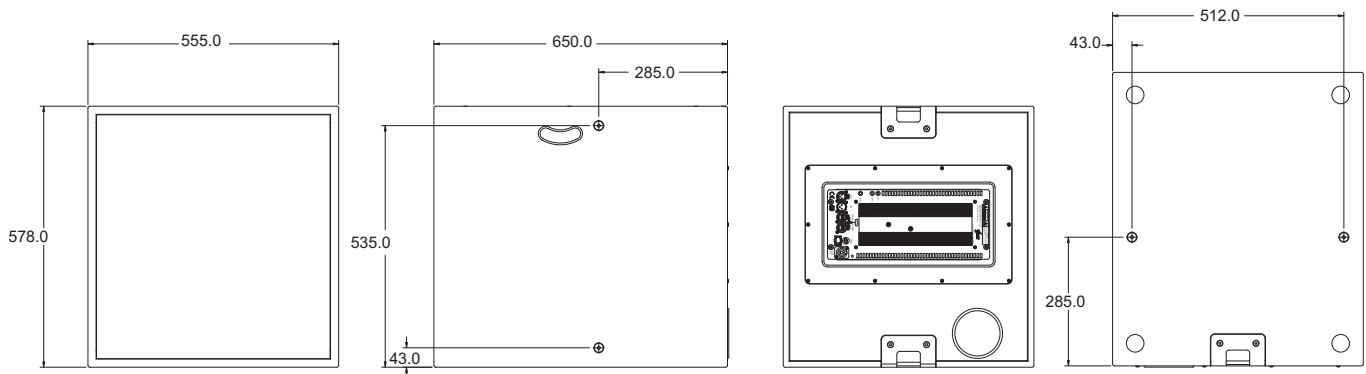

VNET 15

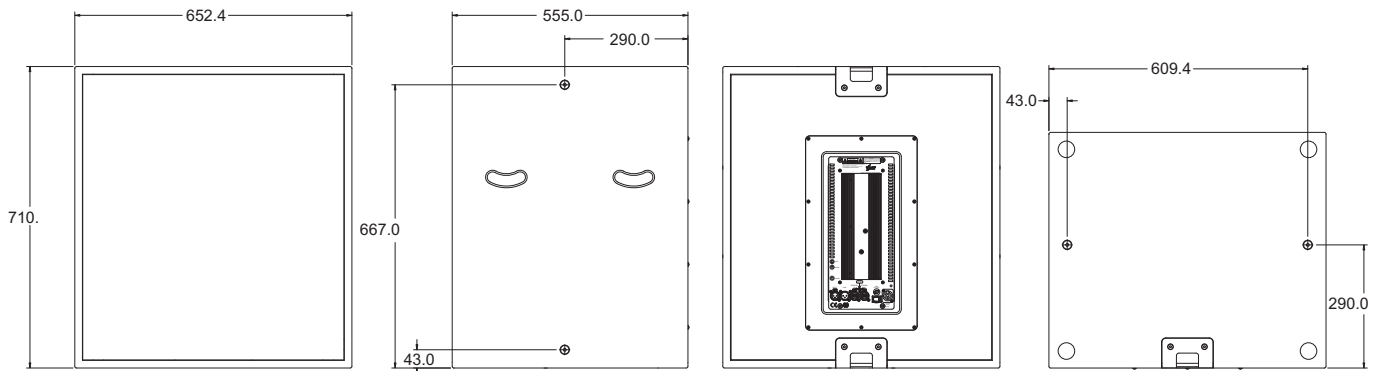

VNET12 Anechoic Frequency Response

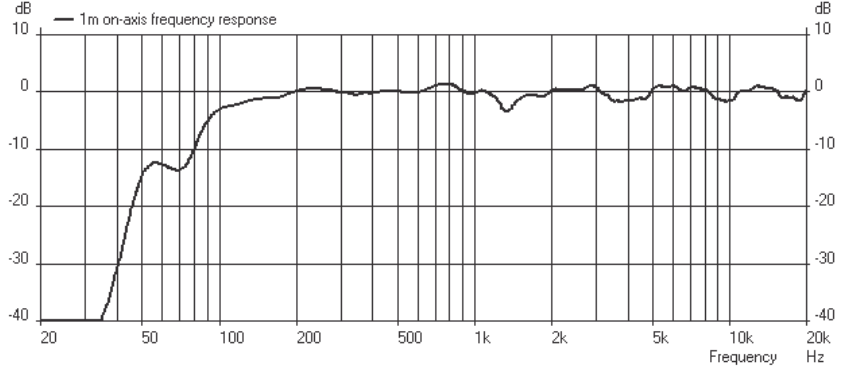

VNET12 HP Anechoic Frequency Response

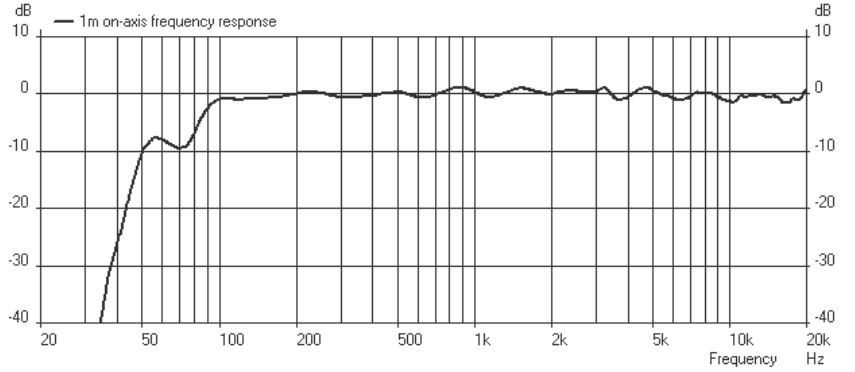

VNET300 Anechoic Frequency Response

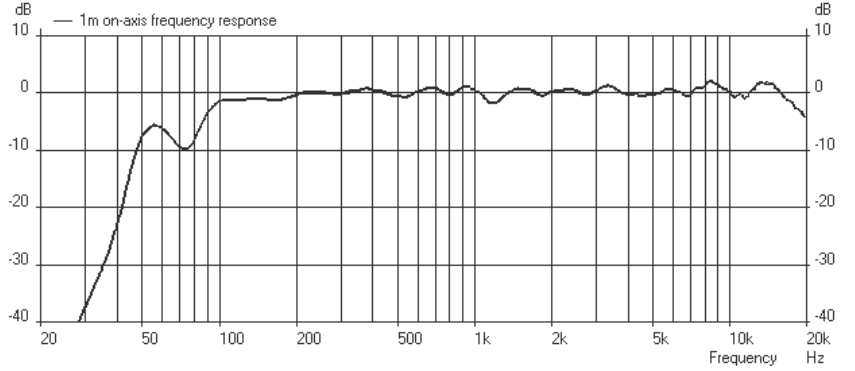

VNET15 Anechoic Frequency Response

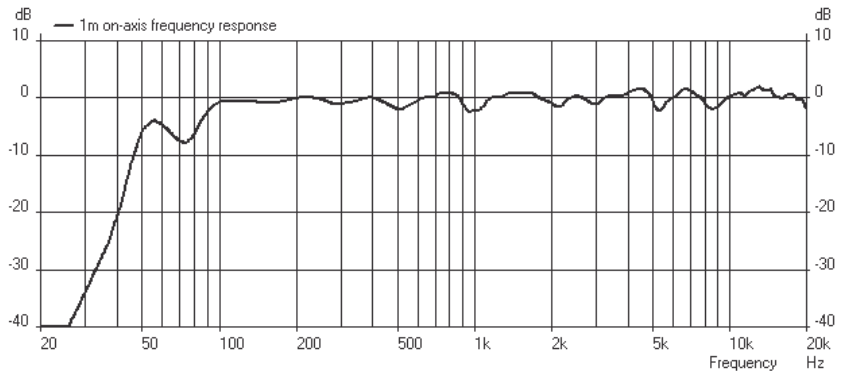



SYSTEM	VNET 12	VNET 12HP	VNET 15	VNET 300
<b>System Type</b>	Full Range - Vented	Full Range - Vented	Full Range - Vented	Full Range - Vented
Frequency Response (1) +/- 2dB	60Hz - 25kHz	55Hz - 23Hz	40Hz - 23Hz	45Hz - 23kHz
Maximum SPL(2) <b>Average</b>	120dB	124dB	126dB	122dB
<b>Peak</b>	126dB	130dB	132dB	128dB
Dispersion (-6dB)	90° Conical	75° Conical	75° Conical	90° Conical
Driver Complement	1 x 300mm (12") Dual Concentric™	1 x 300mm (12") PowerDual™	1 x 380mm (15") PowerDual™	1 x 300mm (12") PowerDual™
Crossover (DSP Generated)	1.5kHz Variable high pass filter for use with subwoofers	1.7kHz	1.7kHz	1.8kHz
<b>DI Averaged (PCQ)</b>	10.1, 500 Hz - 16 kHz	11.0, 500 Hz - 16 kHz	11.2, 500 Hz - 16 kHz	11.0, 500 Hz - 16 kHz
@ 1kHz (ISO)	7.6	8.0	9.5	8.1
@ 2kHz (ISO)	9.6	11.1	10.5	11.6
@ 4kHz (ISO)	8.6	9.1	11.1	9.9
@ 8kHz (ISO)	13.8	13.4	10.1	13.3
@ 16kHz (ISO)	14.7	17.3	18.4	16.4
<b>Q Averaged (PCQ)</b>	13.5, 500 Hz - 16 kHz	18.0, 500 Hz - 16 kHz	19.8, 500 Hz - 16 kHz	16.7, 500 Hz - 16 kHz
@ 1kHz (ISO)	5.8	6.4	8.8	6.4
@ 2kHz (ISO)	9.1	12.9	11.3	14.4
@ 4kHz (ISO)	7.3	8.2	12.9	9.7
@ 8kHz (ISO)	24.0	21.9	10.3	21.5
@ 16kHz (ISO)	29.9	53.8	69.3	43.8
<b>Distortion</b>				
0.1 Full Power	<b>2nd Harmonic</b> <b>3rd Harmonic</b>	<b>2nd Harmonic</b> <b>3rd Harmonic</b>	<b>2nd Harmonic</b> <b>3rd Harmonic</b>	<b>2nd Harmonic</b> <b>3rd Harmonic</b>
250 Hz	0.316% 0.100%	0.32% 0.89%	1.000% 0.562%	0.316% 0.089%
1000 Hz	1.584% 1.412%	1.58% 3.54%	1.412% 1.000%	0.398% 0.158%
10000 Hz	1.412% 0.45%	5.62% 0.19%	3.981% 1.778%	1.000% 0.100%
0.01 Full Power	<b>2nd Harmonic</b> <b>3rd Harmonic</b>	<b>2nd Harmonic</b> <b>3rd Harmonic</b>	<b>2nd Harmonic</b> <b>3rd Harmonic</b>	<b>2nd Harmonic</b> <b>3rd Harmonic</b>
250 Hz	0.100% 0.141%	0.11% 0.71%	0.316% 0.447%	0.126% 0.032%
1000 Hz	0.316% 0.891%	0.79% 2.53%	0.447% 0.794%	0.100% 0.050%
10000 Hz	0.562% 0.010%	1.94% 0.161%	3.160% 0.316%	0.316% 0.047%

## CONSTRUCTION

<b>Enclosure</b>	37.5 litre Birch Plywood	37.5 litre Birch Plywood	63.5 litre Birch Plywood	44.5 litre Birch Plywood
<b>Finish</b>	Textured Black or White paint (Custom colours on request). Powder Coated Steel Grill (reticulated foam behind)			
<b>Connectors</b>	1 x female XLR (input), 1 x RJ45 (network in), 1 male XLR (link), 1 x RJ45 (network link), 1 x Neutrik Powercon			
<b>Fittings</b>	1 x recessed carrying handle Blanking plate for optional VTH pole mount 8 x M10 flying mount inserts 1 x M10 pull back point 8 x M10 yoke bracket inserts			
<b>Dimensions</b>	486 x 370 x 375mm (19 5/8" x 14" x 14 3/4") 21kg (46lbs 2oz)	486 x 370 x 375mm (19 1/8" x 14" x 14 3/4") 27.5kg (60.10lbs)	590 x 450 x 420mm (23" x 17 3/4" x 16 1/2") 33kg (72lbs 5oz)	590 x 370 x 375mm (23" x 14 5/8" x 14 3/4") 39kg (86lbs 0oz)

NOTES: (1) Average over stated bandwidth. Measured at 1 metre on axis.

(2) Unweighted pink noise input, measured at 1 metre in an anechoic chamber

A full range of measurements, performance data, and Ease™ Data can be downloaded from [www.tannoy.com](http://www.tannoy.com)

Tannoy operates a policy of continuous research and development. The introduction of new materials or manufacturing methods will always equal or exceed the published specifications, which Tannoy reserves the right to alter without prior

SYSTEM	VNET 15BP	VNET 15HL	VNET 18DR
<b>System Type</b>	Subwoofer - Band Pass	Full Range – Horn Loaded	Full Range – Direct Radiating
<b>Frequency Response (1) +/- 3dB</b>	35Hz - 150Hz	48Hz - 250Hz	27Hz - 200Hz
<b>Maximum SPL(2) Average</b>	127dB	130dB	130dB
<b>Peak</b>	133dB	136dB	136dB
<b>Driver Complement</b>	1 x 380mm (15")	1 x 380mm (15")	1 x 458mm (18")
<b>Bass Unit</b>			
<b>Crossover (DSP Generated)</b>	Variable LPF	Variable LPF	Variable LPF
<b>Distortion</b>			
<b>0.1 Full Power</b>			
50 Hz	<b>2nd Harmonic</b> 0.22%	<b>3rd Harmonic</b> 0.71%	<b>2nd Harmonic</b> 0.25%
100 Hz	0.56%	0.31%	0.20%
<b>0.01 Full Power</b>			
50 Hz	<b>2nd Harmonic</b> 0.21%	<b>3rd Harmonic</b> 0.31%	<b>2nd Harmonic</b> 0.19%
100 Hz	0.25%	0.18%	0.14%
			<b>3rd Harmonic</b> 0.10%

**CONSTRUCTION**

<b>Enclosure</b>	100 litre Bandpass 15mm (5/8") multiple-ply birch plywood	Horn Loaded 18mm (11/16") multiple-ply birch plywood	202 litre Direct Radiating 18mm (11/16") multiple-ply birch plywood
<b>Finish</b>	Textured Black or White paint (Custom colours on request).		
<b>Connectors</b> 1 x Neutrik Powercon	1 x female XLR (input), 1 x RJ45 (network in), 1 male XLR (link), 1 x RJ45 (network link),		
<b>Fittings</b>	2 x recessed carrying handle 2 x recessed carrying handle 4 x recessed carrying handle Blanking plate for optional VTH pole mount 8 x M10 inserts for flying 4 x rubber feet		
<b>Dimensions</b>	665 x 440 x 440mm (26 <sup>3</sup> / <sub>16</sub> " x 17 <sup>5</sup> / <sub>16</sub> " x 17 <sup>5</sup> / <sub>16</sub> ") Weight 31kg (70lbs)	578 x 555 x 650mm (22" x 21 <sup>7</sup> / <sub>8</sub> " x 25 <sup>9</sup> / <sub>16</sub> ") 44kg (98lbs 10oz)	790 x 685 x 900mm (27 <sup>15</sup> / <sub>16</sub> " x 25 <sup>9</sup> / <sub>16</sub> " x 21 <sup>7</sup> / <sub>8</sub> ") 55kg (121lbs)

NOTES: (1) Average over stated bandwidth. Measured at 1 metre on axis.

(2) Unweighted pink noise input, measured at 1 metre in an anechoic chamber

A full range of measurements, performance data, and Ease™ Data can be downloaded from www.tannoy.com

Tannoy operates a policy of continuous research and development. The introduction of new materials or manufacturing methods will always equal or exceed the published specifications, which Tannoy reserves the right to alter without prior

**ELECTRONICS (Common to all models)**

<b>Efficiency</b>	>85% typically						
<b>Damping Factor</b>	120 ref 8Ω						
<b>Distortion</b>	<0.05% @ 1kHz -3dB output (22kHz bandwidth)						
<b>Input Impedance</b>	5.6kΩ unbalanced, 11.2kΩ balanced						
<b>Output Power (Programme)</b>	<b>VNET 12</b> 400W LF 400W HF (limited)	<b>VNET 12HP</b> 700W LF 700W H (limited)	<b>VNET 15</b> 800W LF 800W HF (limited)	<b>VNET 300</b> 500W LF 500W HF (limited)	<b>VNET15BP</b> 600W	<b>VNET15HL</b> 800W	<b>VNET18DR</b> 1200W
<b>Input Sensitivity</b>	1.4V (+5.5dBu)						
<b>System Type</b>	Dual channel Class D						

**DSP system (Common to all models)**

<b>Comms Facilities</b>	Firmware updatable and selected parameters editable
<b>Communications</b>	Serial - RS485 Proprietary message format
<b>Dynamic Range</b>	112dB(A) typical
<b>DSP</b>	3rd generation SHARC
<b>Sampling Frequency</b>	96kHz 24 bit A/D-D/A word length
<b>Format</b>	1 IN - 2 OUT

**PSU specifications (Common to all models)**

<b>Input Connector</b>	Locking Neutrik Powercon
<b>Voltage Selection</b>	Automatic (115 / 230V, 45 - 65Hz)
<b>Switching Frequency</b>	192kHz Synchronised to DSP



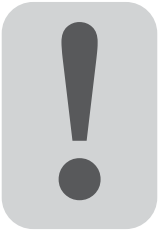

The Tannoy Professional hardware covered in this guide has been designed to offer quick, simple, cost effective and secure solutions for mounting specific Tannoy Professional loudspeakers. This hardware has been designed and manufactured with a high safety load factor for its specific role. To ensure the safest possible use of the hardware covered in this guide, it must be assembled in strict accordance with the instructions specified. The information in these manuals relating to the assembly and the safe use of these accessories must be understood and followed. The installation of Tannoy Professional loudspeakers using the dedicated hardware should only ever be carried out by fully qualified installers, in accordance with all the required safety codes and standards that are applied at the place of installation.

**WARNING:** As the legal requirements for flying change from country to country, please consult you local safety standards office before installing any product. We also recommend that you thoroughly check any laws and bylaws prior to commencing work.

Tannoy Professional hardware has been designed for use with specific Tannoy Professional loudspeakers, and is not designed or intended for use with any other Tannoy Professional products, or any other devices. Using Tannoy Professional hardware for any purpose other than that indicated in this guide is considered to be improper use. Such use can be very dangerous as overloading, modifying; assembling in anyway other than that clearly stated in the manual, or damaging Tannoy Professional hardware will compromise safety.

The component parts of any Tannoy Professional hardware device must only be assembled using the accessory kits supplied and in strict compliance with the user manual. The use of other accessories or non-approved methods of assembly may result in an unsafe hardware system by reducing the load safety factor. Welding, or any other method of permanently fixing hardware components together or to the integral fixing points in the cabinet should never be used.

Whenever a Tannoy Professional loudspeaker is fixed to a surface using a Tannoy Professional hardware device, the installer must ensure that the surface is capable of safely and securely supporting the load. The hardware employed must be safely, securely, and in accordance with the manual, attached both to the loudspeaker and also to the surface in question, using only the fixing holes provided as standard and covered in the manual. Secure fixings to the building structure are vital. Seek help from architects, structural engineers or other specialists if in any doubt.

All loudspeakers flown in theatres, nightclubs, conference centre or other places of work and entertainment must, be provided with an independent, correctly rated and securely attached secondary safety – in addition to the principle hardware device. This secondary safety must prevent the loudspeaker from dropping more than 150mm (6") should the principle hardware device fail.

#### 14.1 : SECUR ET - VMY YOKE BRACKET

The VMY is an adjustable yoke bracket (available in both black and white), allowing the user to fly the Tannoy **VNET™** Full Range loudspeakers in either portrait or landscape orientations using the same bracket (Figures 1 & 2).

 The Tannoy **VNET™** loudspeaker is attached to the bracket using the M10 bolts and washers supplied in the accessory pack. Only the screws, fasteners, shake proof and plain washers specified on figure 3. should be used to assemble the VMY bracket

Pivot studs (Figure 3.) (Supplied with the VMY) are attached to the cabinet using the M10 bolts supplied. These bolts locate on the M10 inserts in the cabinet. The VMY adjustable yoke bracket then connects to the centre of these mounting plates (using the M10 screws supplied). These bracket pick up points which are in line with the bracket's axis of rotation, are also positioned on the centre of gravity of the **VNET™** in both orientations to allow easy adjustment for optimum coverage.

The vertical distance between the apex of the VMY and the top of the Tannoy **VNET™** loudspeaker can be adjusted by connecting to varying mounting points on the bracket allowing varying degrees of vertical rotation. The top centre fixing hole of the VMY then provides a pick up point for a variety of Tannoy Professional hardware accessories including the VMB wall mounting plate (shown in Figure 2.), the VCS ceiling saddle, and the VPC pole clamp.



Fig.1

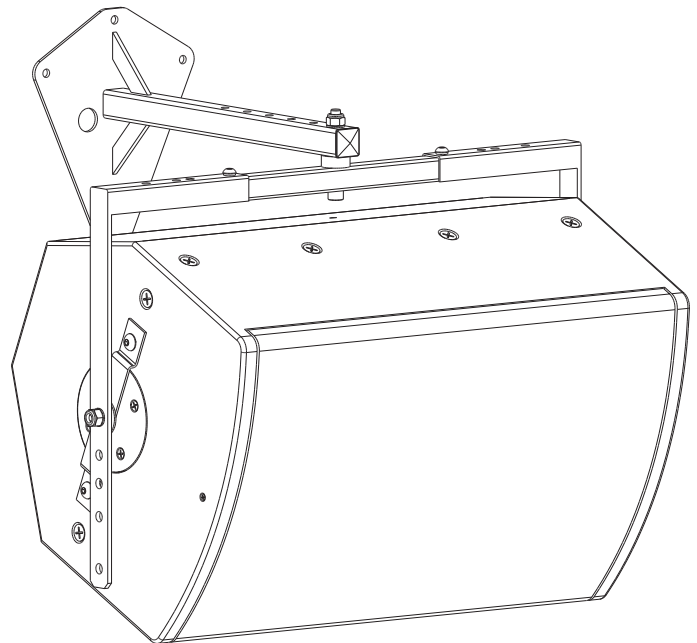

Fig.2

Use the table of parts along with the assembly drawing (Figure 3.) to assemble the VMY. Figure 4 shows the VMY assembled.

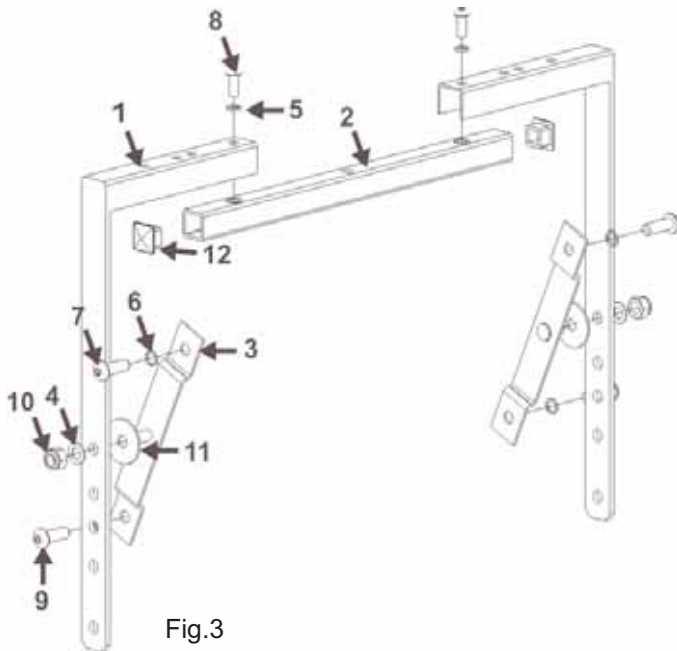

Fig.3

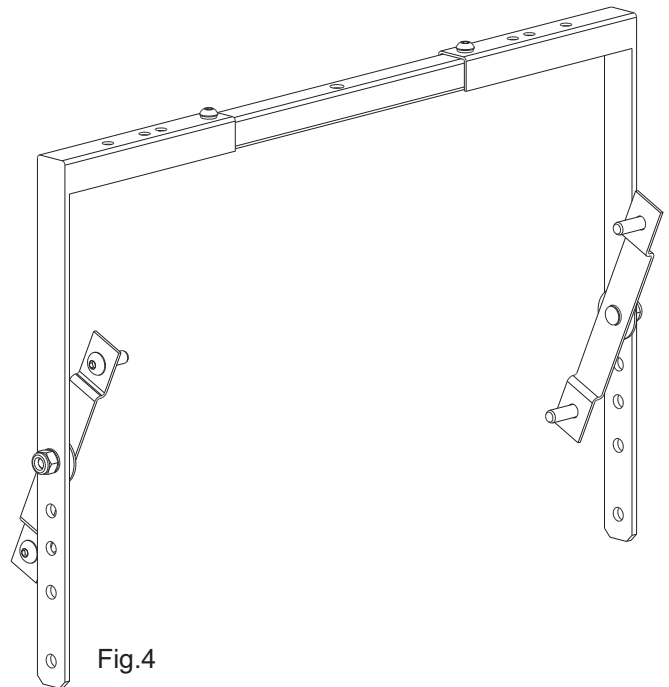
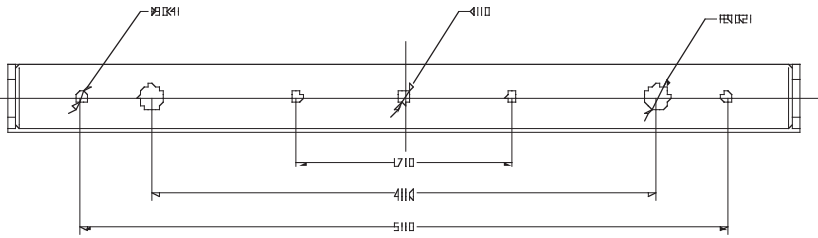
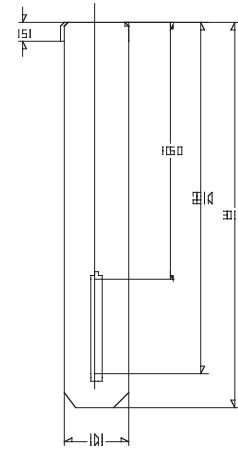

Fig.4

Number on Assembly View (Fig 3.)	Description	Quantity
1	Hanging Bracket	2
2	Cross Member	1
3	Pivot Stud	2
4	M10 Plain Washer	2
5	M8 Spring Washer	2
6	M10 Spring Washer	4
7	M10 x 30mm Screw	2
8	M8 x 20mm Screw	2
9	M10 x 30mm Screw	2
10	M10 Nyloc Nut	2
11	Friction Washer	2
12	30mm Square Blank Plug	2



V15Y



V12Y

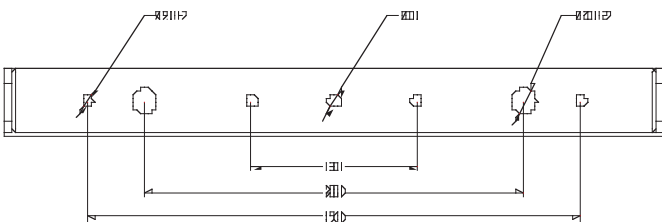
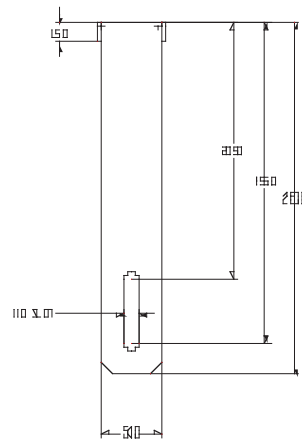
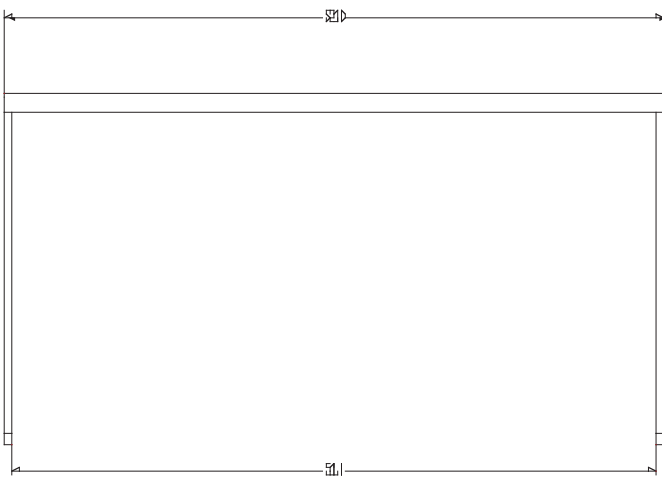
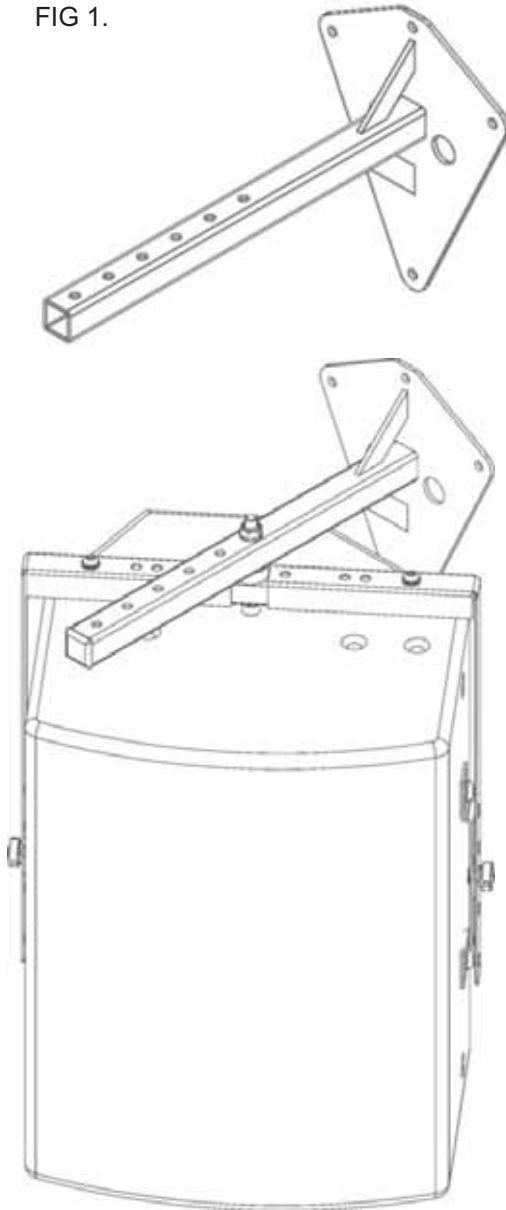

FIG 1.



The VMB is wall mounting bracket for the attachment of a VMY, available in both black and white finishes, allowing the user secure the Tannoy **VNET™** Full range loudspeaker in either portrait or landscape orientations to a wall.

The Tannoy **VNET™** loudspeaker is attached to the bracket using the accessories supplied.

This wall-mounting bracket has a larger wall plate than previous models to maximise the integrity of fixing obtained. There are also two holes either side of the fixing beam to allow the speaker cable the pass through the wall plate and along the fixing beam to the terminal panel resulting in a more discrete installation.

The fixing beam on the VMB has a number of mounting points from which the VMY, V12Y & V15Y can be attached at varying distances from the mounting surface.



**Only the screws, fasteners, shakeproof and plain washers specified on figure 3. should be used to assemble the VMB bracket**

FIG 2.

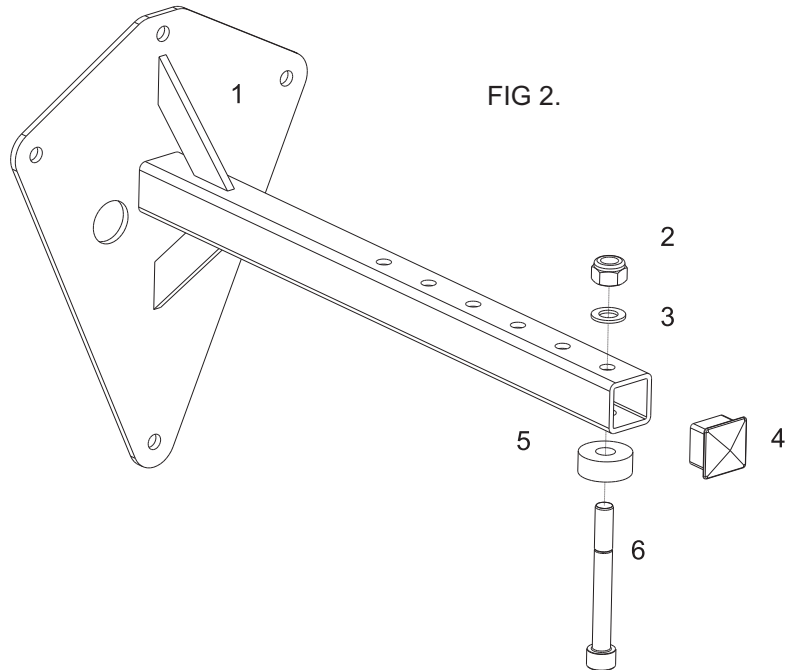

Number on Fig 3.	Description	Quantity
1	VMB Wall Bracket	1
2	M10 Nyloc Nut	1
3	M10 Plain Washer	1
4	30mm Square Blank Plug	1
5	Nylon Spacer	1
6	M10 x 85mm Screw	1

FIG 1.

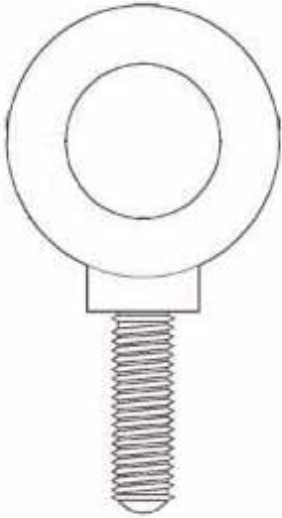

The Tannoy **VNET™** loudspeaker can be flown with high quality VEB M10 eyebolts with collar to BS4278:1984. The loudspeakers are equipped with internal steel braces, which also double as the flying points, and accept VEB M10 eyebolts.

To install the VEB M10 eyebolts remove the original M10 counter sunk screws from the locations you wish to install the VEB M10 eyebolts. Then replace these counter sunk M10 screws with the VEB M10 eyebolts. The M10 insert on the rear of the cabinet also accepts a VEB M10 eyebolt and should **only** be used for tilting the loudspeaker to the desired angle.



**Important:** It is imperative for safety reasons that two eyebolts linked to two independently fixed straps are used per cabinet. VEB eyebolts should be installed into the relative sides of the cabinet, and should **NEVER** be installed on the top of the cabinet. Never suspend one enclosure from another to form a line array or cluster using these fittings.

The correct method is shown in figure 2.

Never attempt to use formed eyebolts i.e. formed from a steel rod and bent into an eye.

Only use the outer fixing points on the top and sides of the **VNET™** cabinet for fixing eyebolts. The inner two fixing points on each side of the cabinet are for dedicated bracketry (VMY) only.

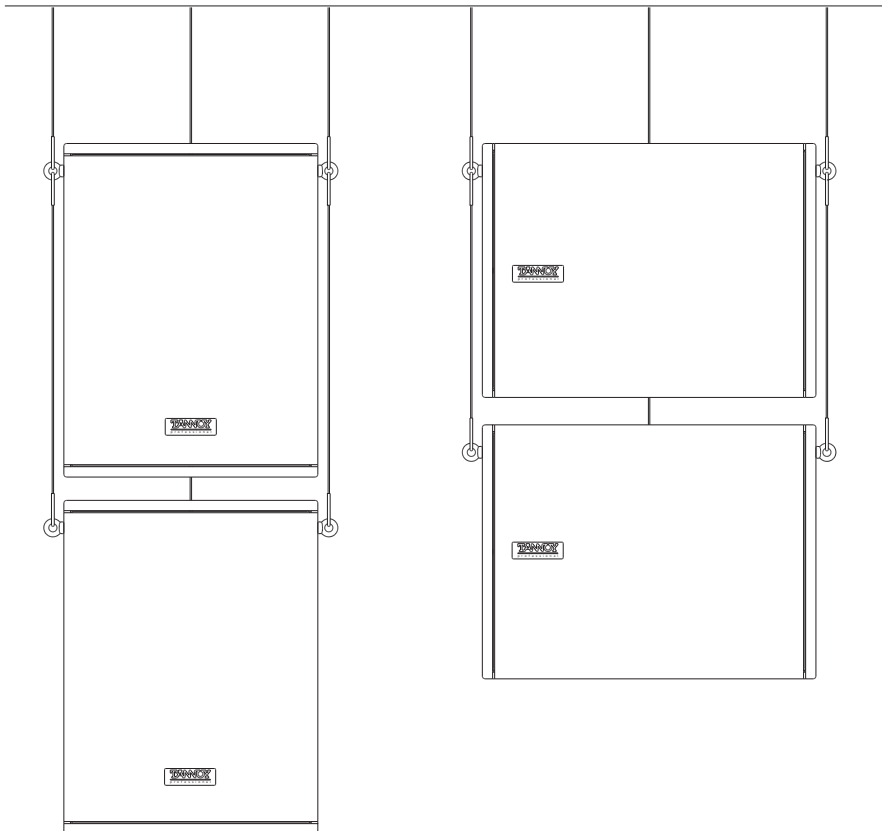
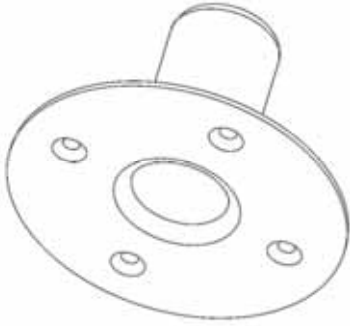

FIG 2.

14.5 : SECUR ET - VTH POLE MOUNT



The Tannoy **VNET™** loudspeakers are fitted as standard with a blanking plate on the base of the cabinet. However, should you ever wish to mount the **VNET™** onto a standard 35mm pole mount this blanking plate can be quickly and easily removed and replaced by a VTH pole mount. The same screws which secure the blanking plate should be used to secure the VTH in position.

14.6 : SECUR ET VCS CEILING SADDLE

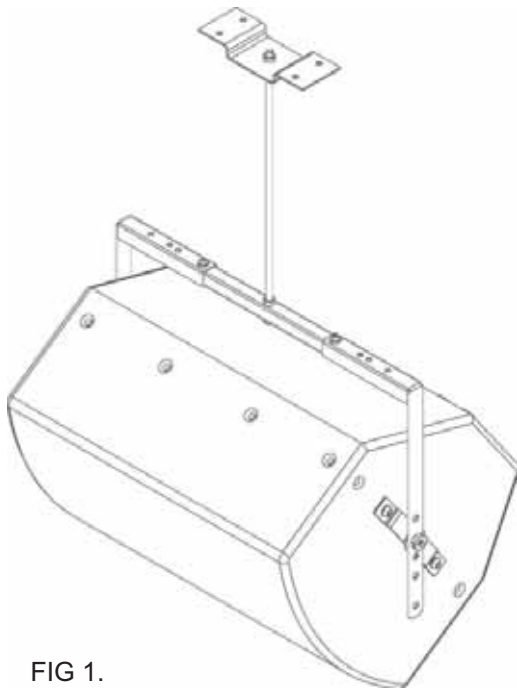
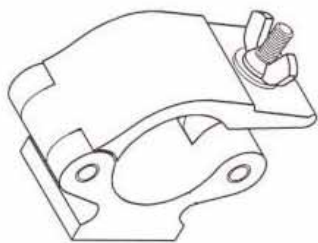

FIG 1.

The VCS ceiling saddle available in both black and white finishes, and is to be used in conjunction with the VMY and a length of M10 threaded rod (not supplied by Tannoy Limited). The VCS ceiling saddle allows the Tannoy **VNET™** loudspeaker to be suspended at a user defined distance from the ceiling as shown in Figure 1.

Included with the VCS is an M10 nut. This should be used to secure and lock the threaded rod in place at the top of the ceiling saddle.

14.6 : SECUR ET VPC POLE CLAMP



The VPC pole clamp can be used along with the VMY yoke bracket to suspend a Tannoy **VNET™** loudspeaker from an overhead bar, truss or suitable structure. Only the parts supplied should be used to secure the VPC to the VMY yoke bracket.

The following items are included with each VPC:-

Description	Quantity
VPC Pole Clamp	1
M10 Washer	1
M10 x 50mm Screw	1
M10 Nyloc Nut (Black)	1



<b>Full Range</b>	VNET Amplifier & DSP Module
7300 1045	Duals
7300 1062	Subs
<b>VNET12</b>	
7900 0433	Driver Kit - 3142
7900 0441	Recone Kit - 3142
7900 0199	HF Diaphragm Kit
<b>VNET12HP</b>	
7900 0715	Driver Kit - 3190
7900 0716	Recone Kit – 3190
7900 0717	HF Driver
7900 0718	HF Diaphragm Kit
<b>VNET15</b>	
7900 0644	Driver Kit - 3816
7900 0646	Recone Kit - 3816
7900 0645	HF Diaphragm Kit 0282
<b>VNET300</b>	
7900 0386	Driver Kit - 3138
7900 0387	Recone Kit - 3138
7900 0326	HF Diaphragm Kit
<b>VNET15BP</b>	
7900 0596	Driver Kit - 3813
7900 0600	Recone Kit - 3813
<b>VNET15HL</b>	
7900 0598	Driver Kit – 3815
7900 0602	Recone Kit – 3815
<b>VNET18DR</b>	
7900 0599	Driver Kit - 4505
7900 0603	Recone Kit – 4505
<b>VNET HARDWARE</b>	
8001 2780	VMY – Secur ET – Yoke Adjustable (Black)
8001 2790	VMY – Secur ET – Yoke Adjustable (White)
8001 2800	VMB – Secur ET – Wall Bracket (Black)
8001 2810	VMB – Secur ET – Wall Bracket (White)
8001 2820	VEB – Secur ET – Eyebolts M10
8001 2830	VCS – Secur ET – Ceiling Saddle (Black)
8001 2840	VCS – Secur ET – Ceiling Saddle (White)
8001 2850	VPC – Secur ET – Pole Clamp
8001 2860	VTH – Secur ET – Top Hat (Black)
8001 2870	VTH – Secur ET – Top Hat (White)
8001 3180	V12Y- Secur ET – Yoke Bracket (Black)
8001 3181	V12Y- Secur ET – Yoke Bracket (White)
8001 3190	V15Y- Secur ET – Yoke Bracket (Black)
8001 3191	V15Y- Secur ET – Yoke Bracket (White)
8001 2820	VEB – Secur ET – Eyebolts M10

**16.0: WARRANTY****No maintenance of the VNET™ loudspeakers is necessary.**

All Tannoy professional loudspeaker products are covered by a 5 year warranty from the date of manufacture (1 year for electronics), subject to the absence of misuse, overload or accidental damage. Claims will not be considered if the serial number has been altered or removed. Work under warranty should only be carried out by a Tannoy Professional dealer or service agent. This warranty in no way affects your statutory rights. For further information please contact your dealer or distributor in your country. If you cannot locate your distributor please contact Customer Services, Tannoy Ltd at the address given below.

Customer Services, Tannoy Ltd., Rosehall Industrial Estate, Coatbridge, Strathclyde, ML5 4TF, Scotland.

Telephone: 01236 420199 (National)  
 +44 1236 420199 (International)  
 Fax: 01236 428230 (National)  
 +44 1236 428230 (International)  
 E-Mail: prosales@tannoy.com

**DO NOT SHIP ANY PRODUCT TO TANNOY WITHOUT PREVIOUS AUTHORISATION**

Our policy commits us to incorporating improvements to our products through continuous research and development. Please confirm current specifications for critical applications with your supplier.

**17.0: DECLARATION OF CONFORMITY**

The following apparatus is/are manufactured in UK by Tannoy Ltd of Rosehall Industrial Estate, Coatbridge, Scotland, ML5 4TF. The following equipment is marked with the CE label and conform(s) to the protection requirements of the European Electromagnetic Compatibility Standards and Directives. The apparatus is designed and constructed such that electromagnetic disturbances generated do not exceed levels allowing radio and telecommunications equipment and other apparatus to operate as intended, and, the apparatus has an adequate level of intrinsic immunity to electromagnetic disturbance to enable operation as specified and intended.

Details of the Apparatus: **VNET12**  
**VNET12HP**  
**VNET15**  
**VNET300**  
**VNET15BP**  
**VNET15HL**  
**VNET18DR**

The equipment listed above is covered by this certificate and marked with the CE-label conforms with following standards:

**EN 60065** Safety requirements for mains operated electronic and related apparatus for household and similar general use  
**(IEC 60065)**

**EN 55103-1** Product family standard for audio, video, audio-visual and entertainment lighting control apparatus for professional use. Part 1: Emission.

**EN 55103-2** Product family standard for audio, video, audio-visual and entertainment lighting control apparatus for professional use. Part 2: Immunity.

With reference to regulations in following directives:  
 73/23/EEC, 89/336/EEC

Signed:



Position: Engineering Director – Professional Products, Tannoy Professional

Date: 23/8/2005  
 For Tannoy Ltd









Tannoy United Kingdom	T: +44 (0) 1236 420199	F: +44 (0) 1236 428230	E: <a href="mailto:enquiries@tannoy.com">enquiries@tannoy.com</a>
Tannoy North America	T: (519) 745 1158	F: (519) 745 2364	E: <a href="mailto:inquiries@tannoyna.com">inquiries@tannoyna.com</a>
Tannoy Deutschland	T: 0180 1111 88 1	F: 0180 1111 88 2	E: <a href="mailto:info@tannoy.com">info@tannoy.com</a>

Tannoy adopts a policy of continuous improvement and product specification is subject to change.

[tannoy.com](http://tannoy.com)

