

*** NOTE PRINT PRODUCT PART AND TYPE NUMBER ***

7300 1476

REV XT

A 25/02/15 MP
 B 31/03/15 MP
 C3 REMOVED
 R1 REMOVED

TYPE	DESCRIPTION	NOTES
C1	1 μ 8/160V	5% POLYPROP/MASTIC DAMPED
C2	5 μ 6/100V	5% POLYESTER
L1	0.93mH DCR<0.2R	LAM. IRON CORE
L2	0.5mH DCR<0.2R	LAM. IRON CORE

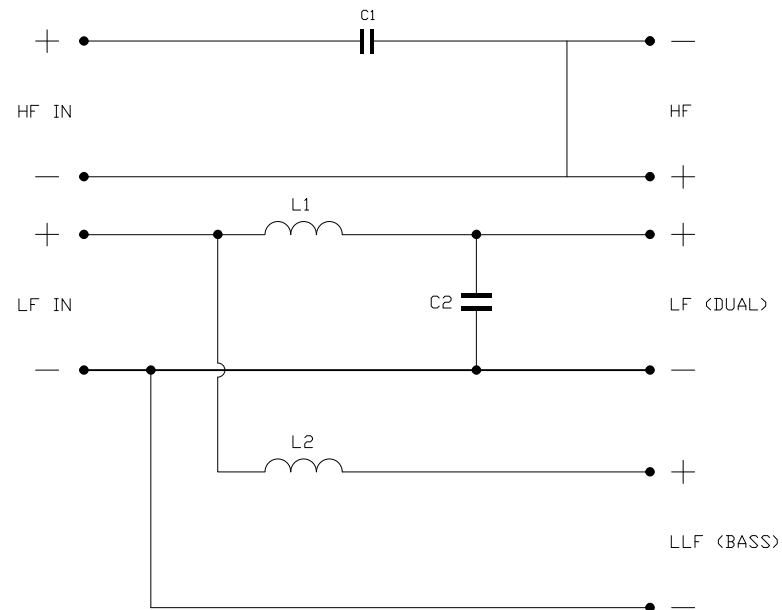

INTERNAL WIRING - EQUIVALENT TO VAN
 DEN HUL CS18 (SILVER PLATED COPPER)

- NOTES:
1. ENSURE COMPONENTS ARE SECURELY FIXED IN PLACE USING HOTMELT, WITH DESCRIPTIONS VISIBLE.
 2. REINFORCE JOINTS AND CABLE TIES WITH HOT MELT ADHESIVE TO ENSURE COMPONENT SECURITY. SEE - 
 3. ENSURE FIXING HOLES ARE CLEAR OF COMPONENTS AND HOTMELT GLUE.
 4. ENSURE COMPONENT L1 IS POSITIONED ON PCB BOARD AS SHOWN.