

- M1
- P22101-D
- J31
- AWG18

TC Electronic A/S		Designer HJE
Title GFLAT		Module title MAINBOARD
Number P22101_D	Revision DAH	Previous page XX
Date 9-7-2011 19:07	Filename P22101_D_A	Page / of 1 / 12

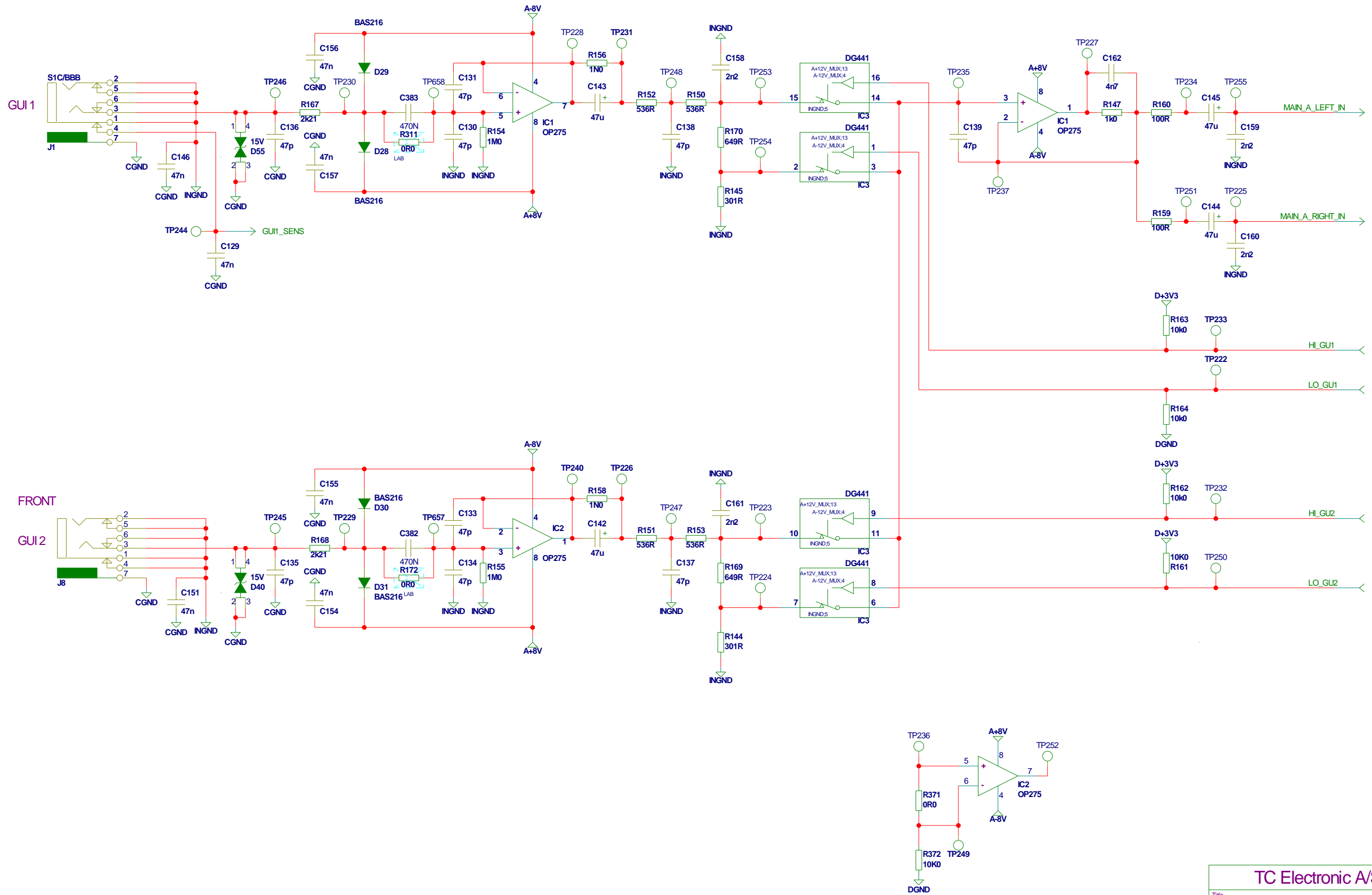

TC Electronic A/S		Designer HJE
Title GFLAT	Module title MAINBOARD	
Number P22101_D	Revision DAH	Previous page XX
Date 9-7-2011 19:07	Filename P22101D_GUITAR_INPUT_A_1	Page / of 2 / 12

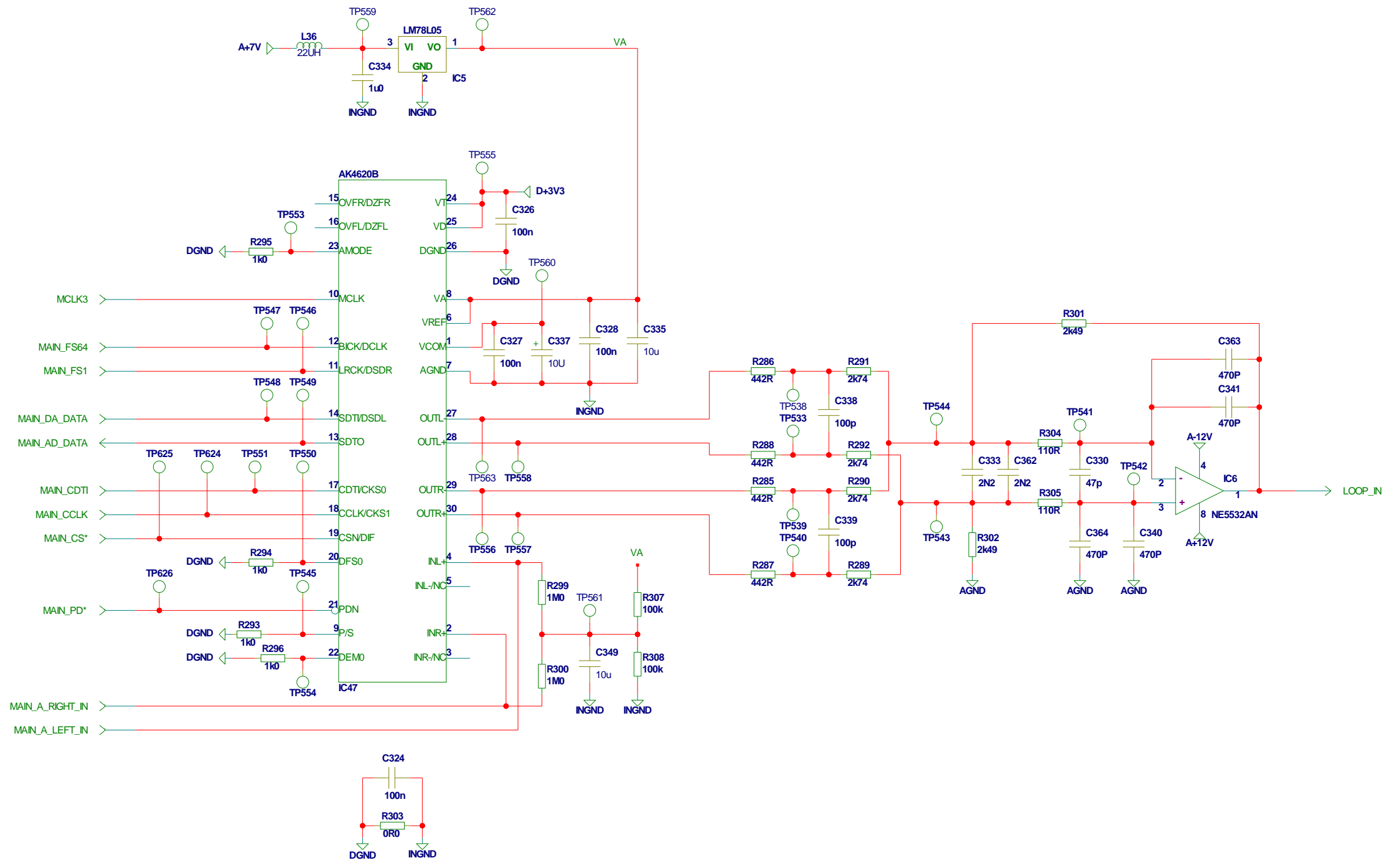

TC Electronic A/S		Designer
		HJE
Title	Module title	
GFLAT	MAINBOARD	
Number	Revision	Previous page
P22101_D	DAH	XX
Date	Filename	Page / of
9-7-2011 19:07	P22101D_MAIN_CODEC_A_1	3 / 12

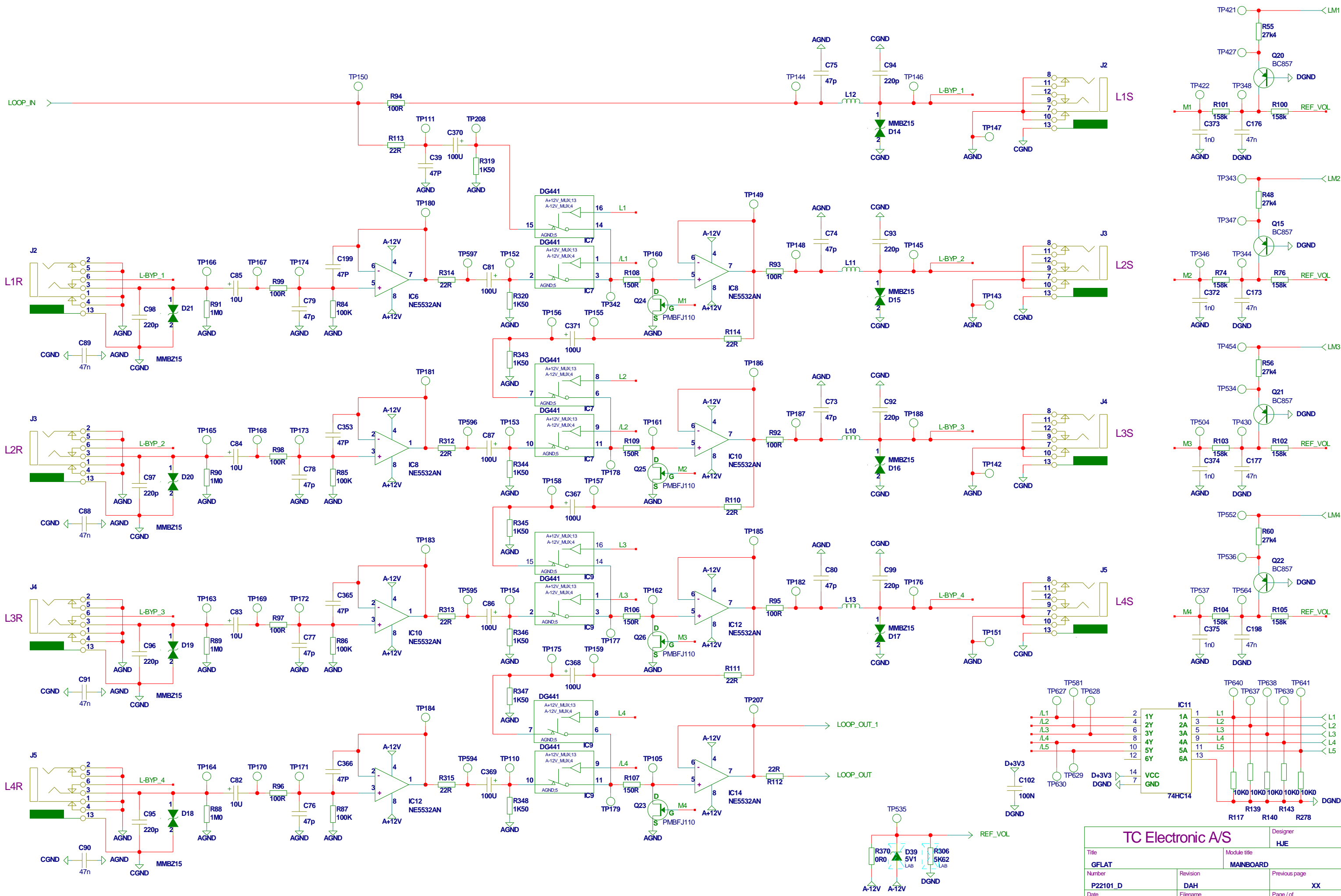

TC Electronic A/S		Designer	HJE
Title	GFLAT	Module title	MAINBOARD
Number	P22101_D	Revision	DAH
Date	9-7-2011 19:07	Filename	P22101D_LOOPS_A_1
		Previous page	XX
		Page / of	4 / 12

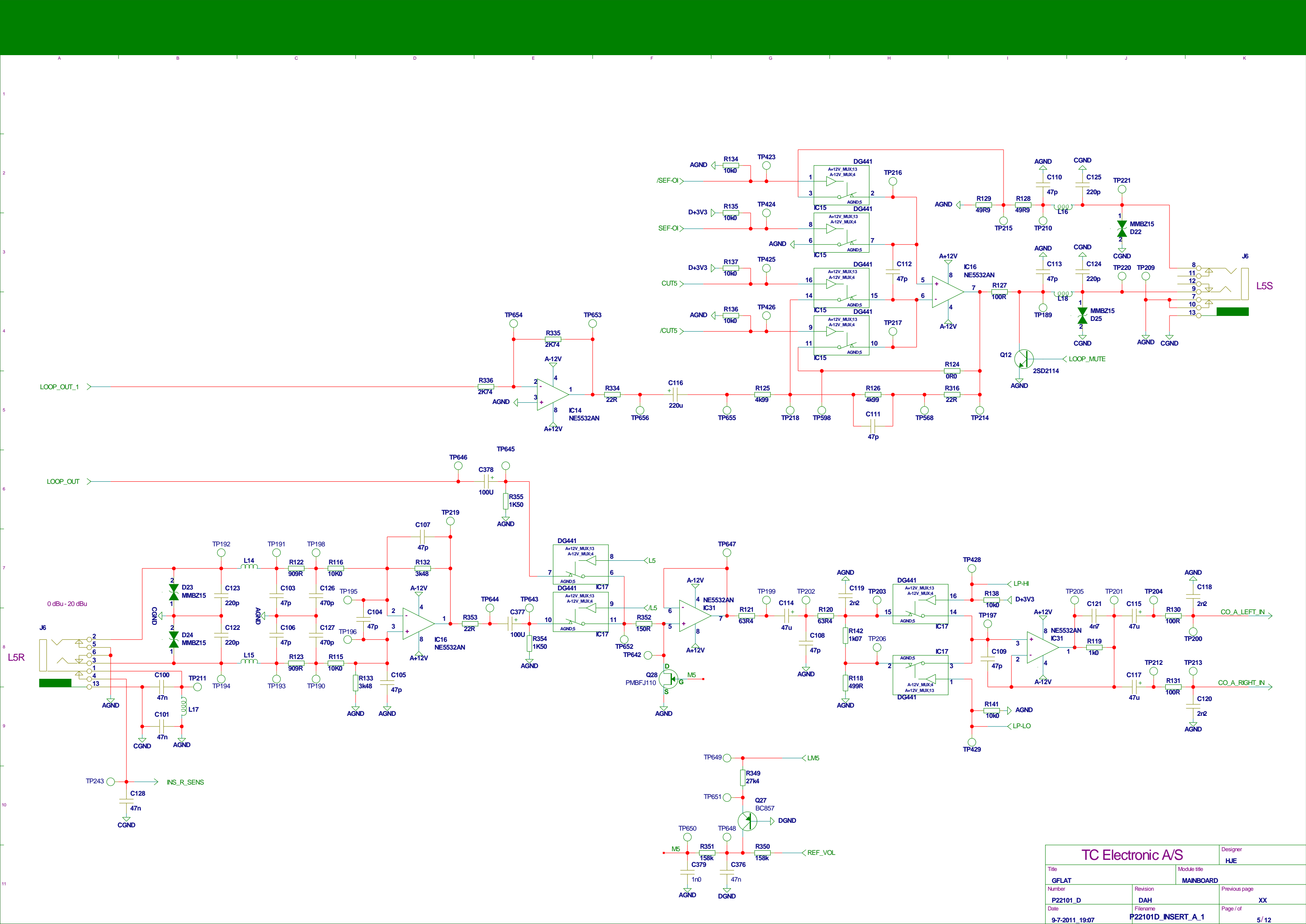

TC Electronic A/S		Designer
		HJE
Title	Module title	
GFLAT	MAINBOARD	
Number	Revision	Previous page
P22101_D	DAH	XX
Date	Filename	Page / of
9-7-2011 19:07	P22101D_INSERT_A_1	5 / 12

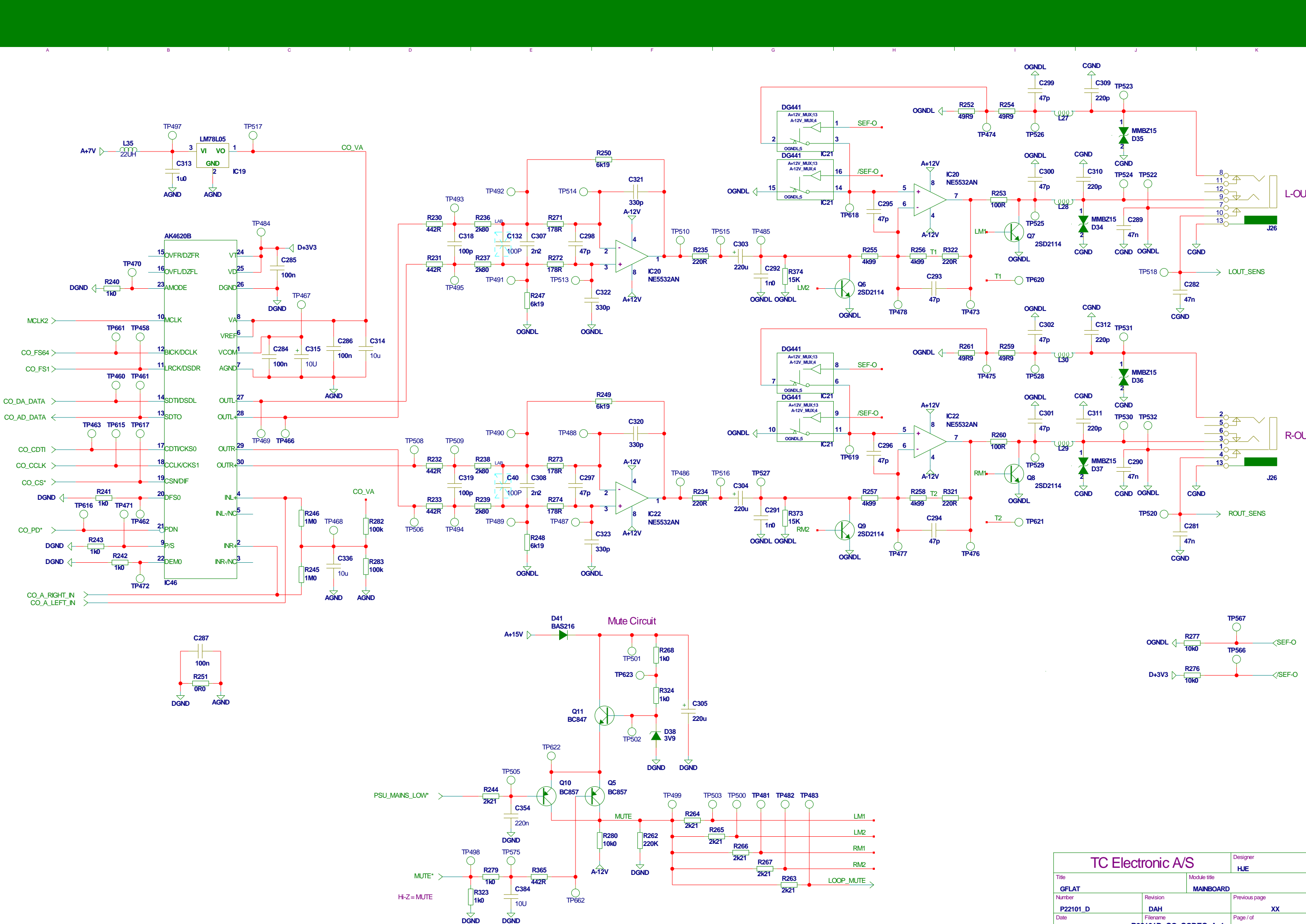
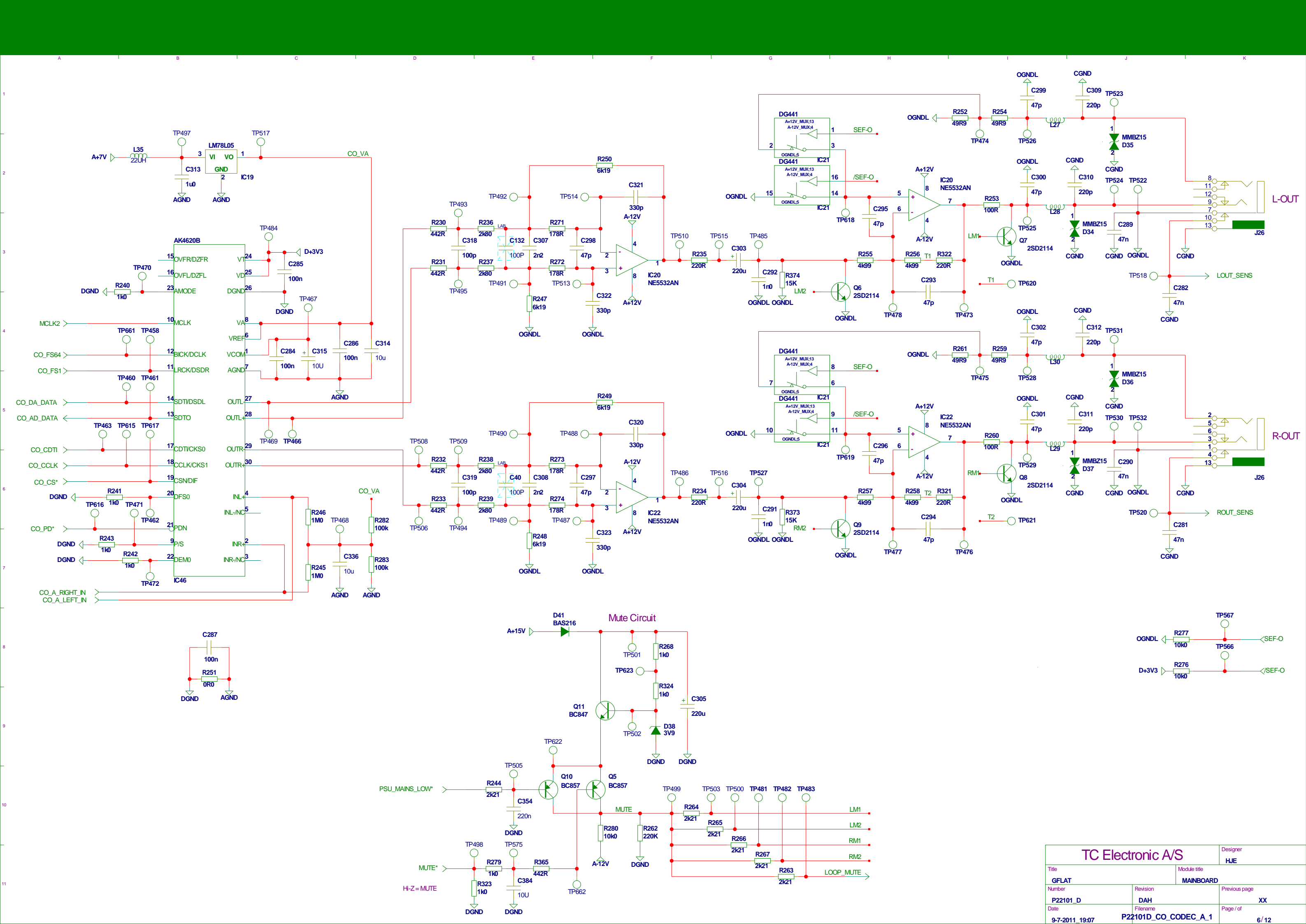

TC Electronic A/S		Designer
		HJE
Title	Module title	
GFLAT	MAINBOARD	
Number	Revision	Previous page
P22101_D	DAH	XX
Date	Filename	Page / of
9-7-2011 19:07	P22101D_CO_CODEC_A_1	6 / 12

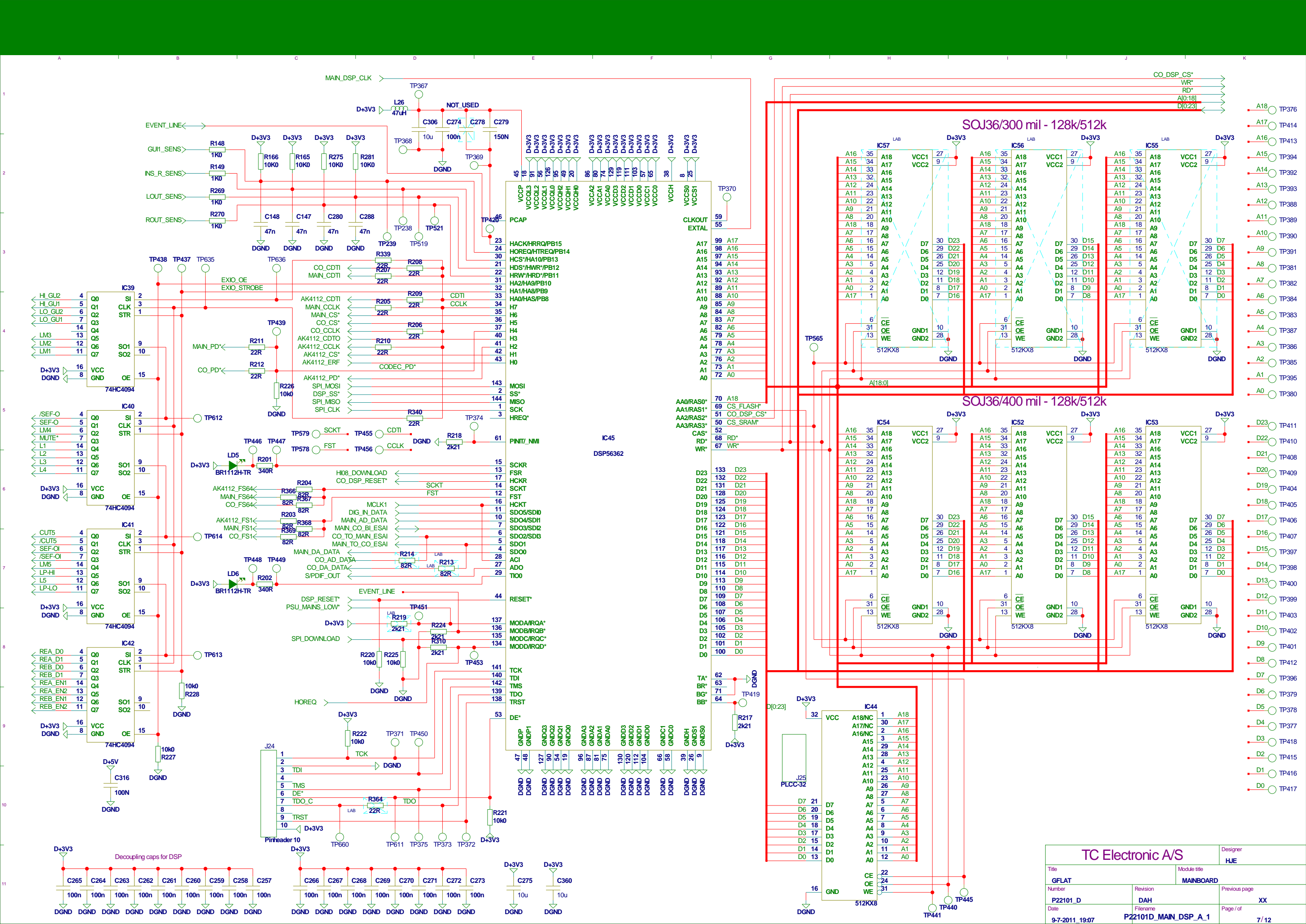

- TP317 A1_18
- TP299 A1_17
- TP300 A1_16
- TP301 A1_15
- TP302 A1_14
- TP303 A1_13
- TP304 A1_12
- TP305 A1_11
- TP306 A1_10
- TP307 A1_9
- TP308 A1_8
- TP309 A1_7
- TP310 A1_6
- TP311 A1_5
- TP312 A1_4
- TP313 A1_3
- TP314 A1_2
- TP315 A1_1
- TP316 A1_0
- TP318 D1_23
- TP319 D1_22
- TP320 D1_21
- TP321 D1_20
- TP322 D1_19
- TP323 D1_18
- TP324 D1_17
- TP325 D1_16
- TP326 D1_15
- TP327 D1_14
- TP328 D1_13
- TP329 D1_12
- TP330 D1_11
- TP331 D1_10
- TP332 D1_9
- TP333 D1_8
- TP335 D1_6
- TP334 D1_7
- TP336 D1_5
- TP337 D1_4
- TP338 D1_3
- TP339 D1_2
- TP340 D1_1
- TP341 D1_0

SOJ36/300 mil - 128k/512k

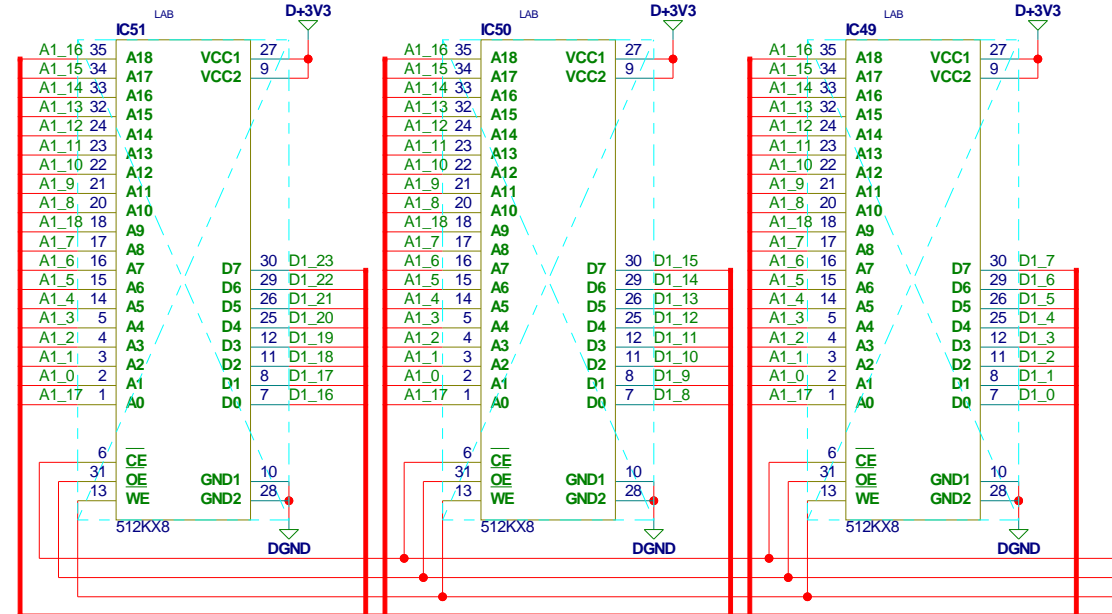

SOJ36/400 mil - 128k/512k

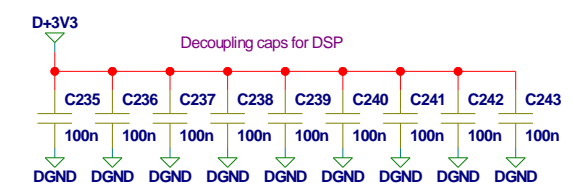
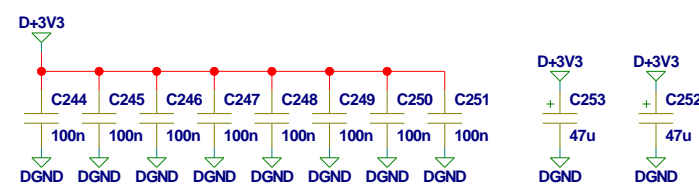
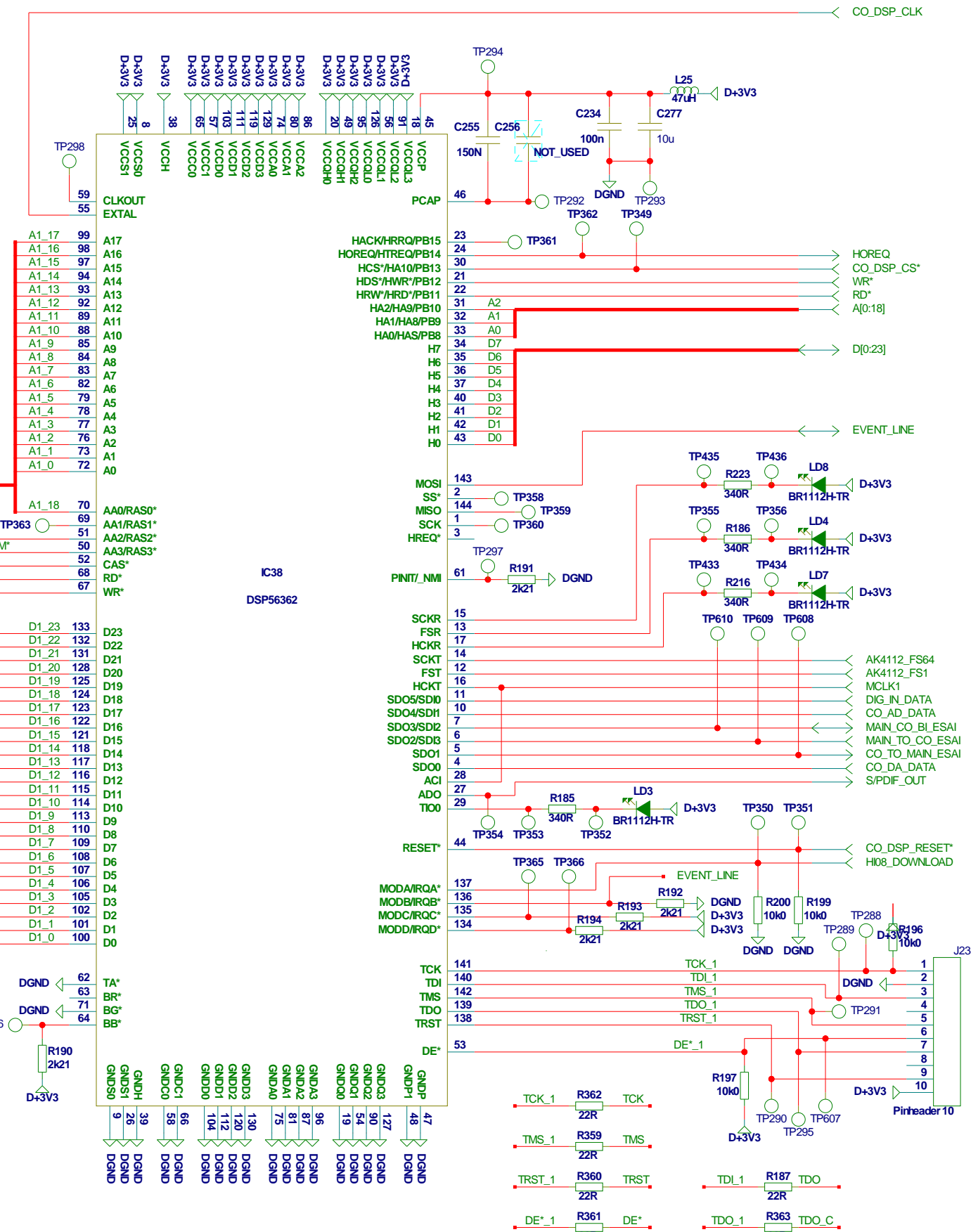
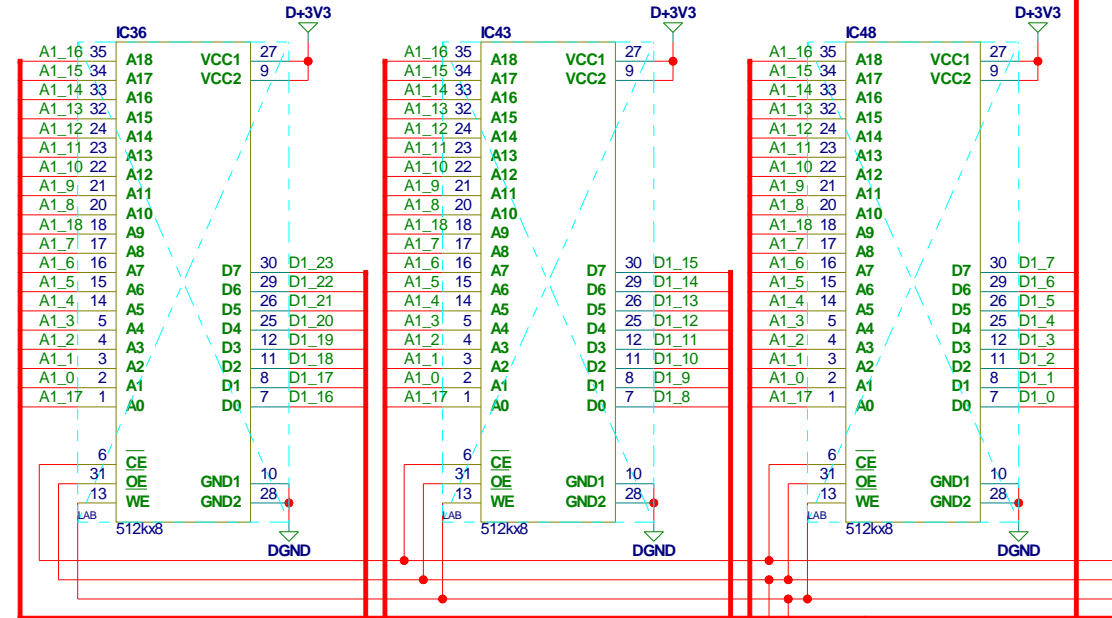

TC Electronic A/S		Designer	HJE
Title	GFLAT	Module title	MAINBOARD
Number	P22101_D	Revision	DAH
Date	9-7-2011 19:07	Filename	P22101D_CO_DSP_A_1
		Previous page	XX
		Page / of	8 / 12

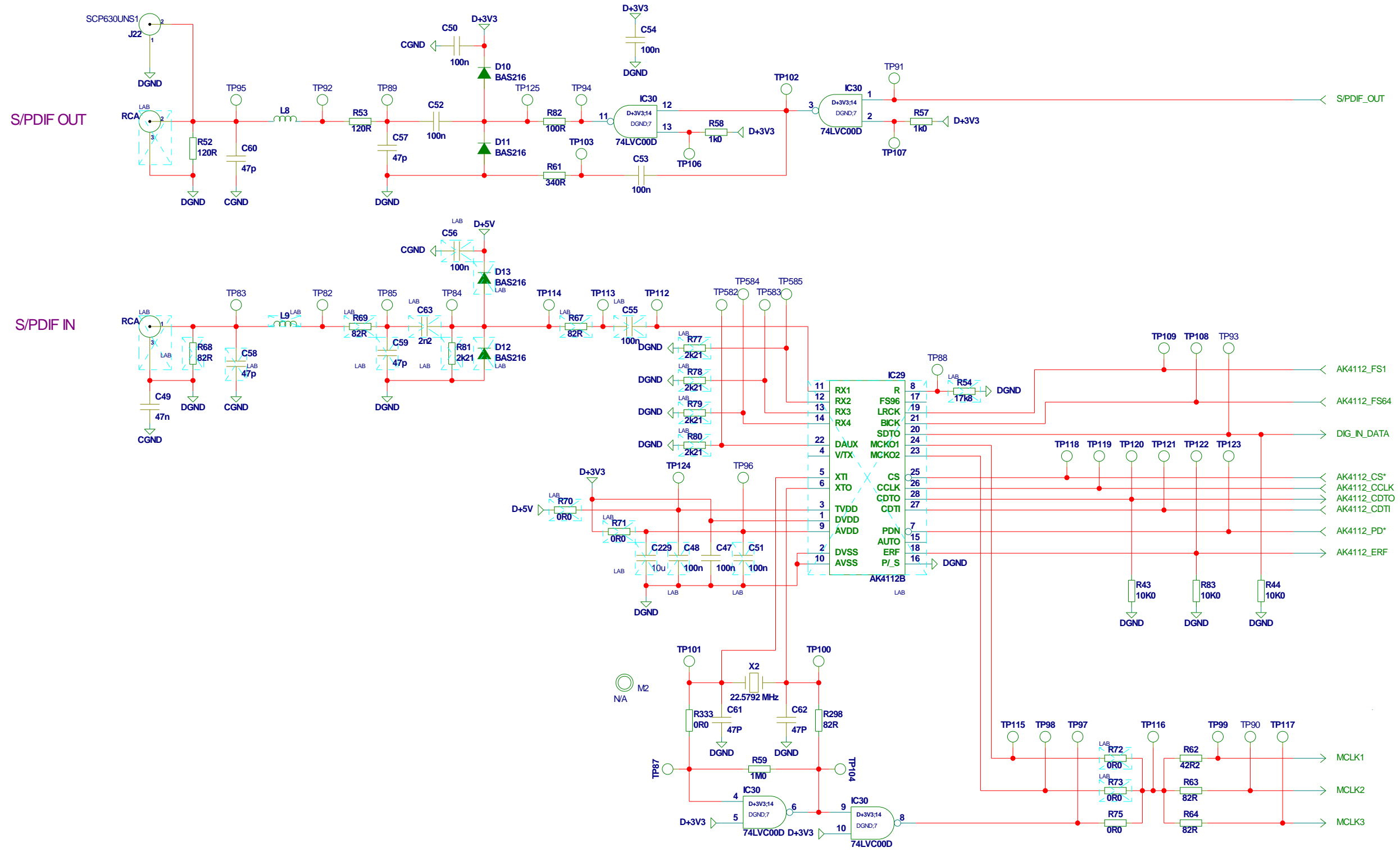

TC Electronic A/S		Designer
GFLAT		HJE
Module title		MAINBOARD
Number	Revision	Previous page
P22101_D	DAH	XX
Date	Filename	Page / of
9-7-2011 19:07	P22101D_DIGITAL_IN_OUT_A_1	9 / 12

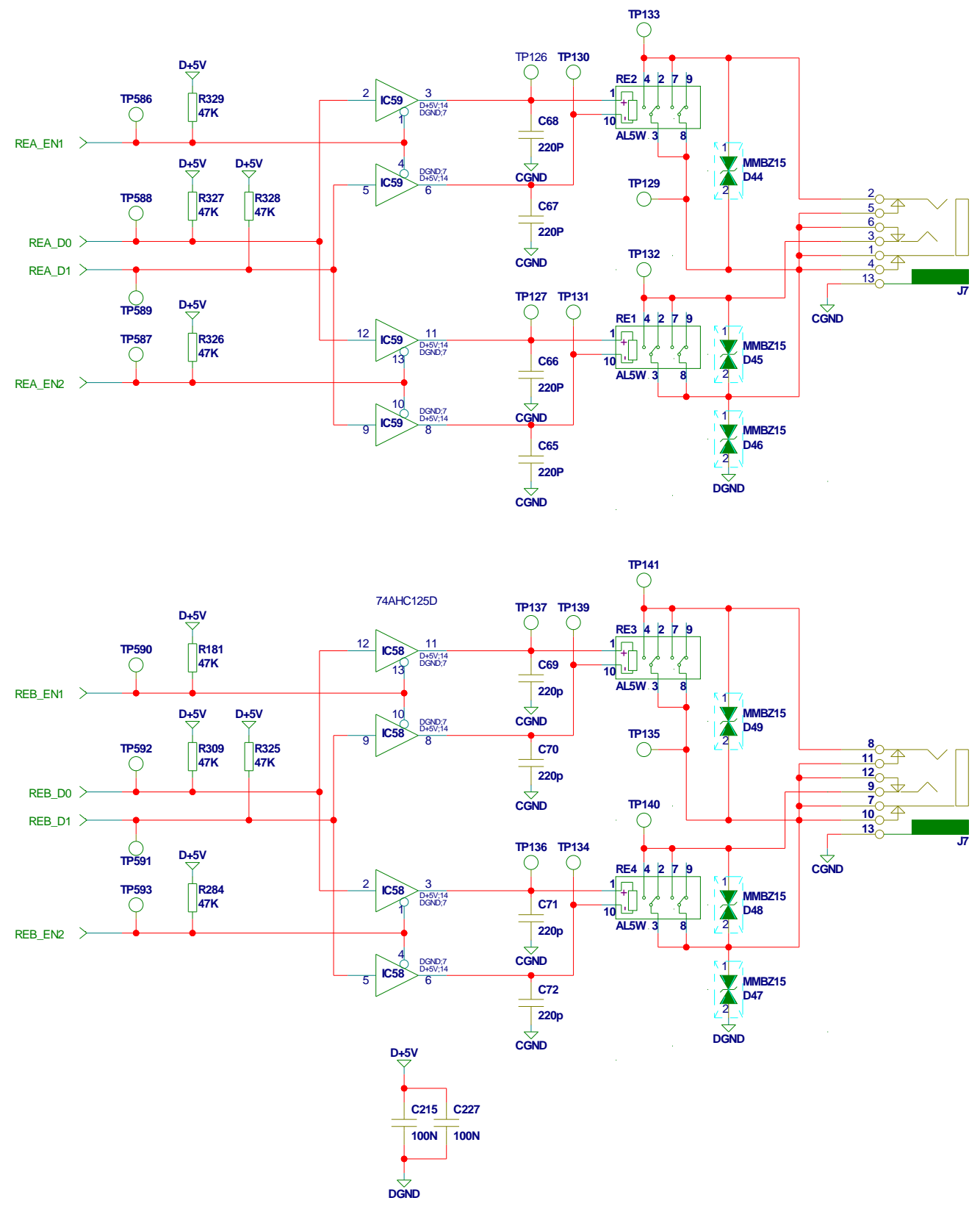

TC Electronic A/S		Designer
		HJE
Title	Module title	
GFLAT	MAINBOARD	
Number	Revision	Previous page
P22101_D	DAH	XX
Date	Filename	Page / of
9-7-2011 19:07	P22101D_SWITCHOUTPUTS_A.1	10 / 12

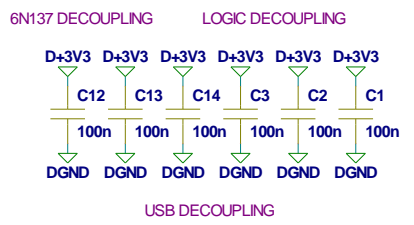
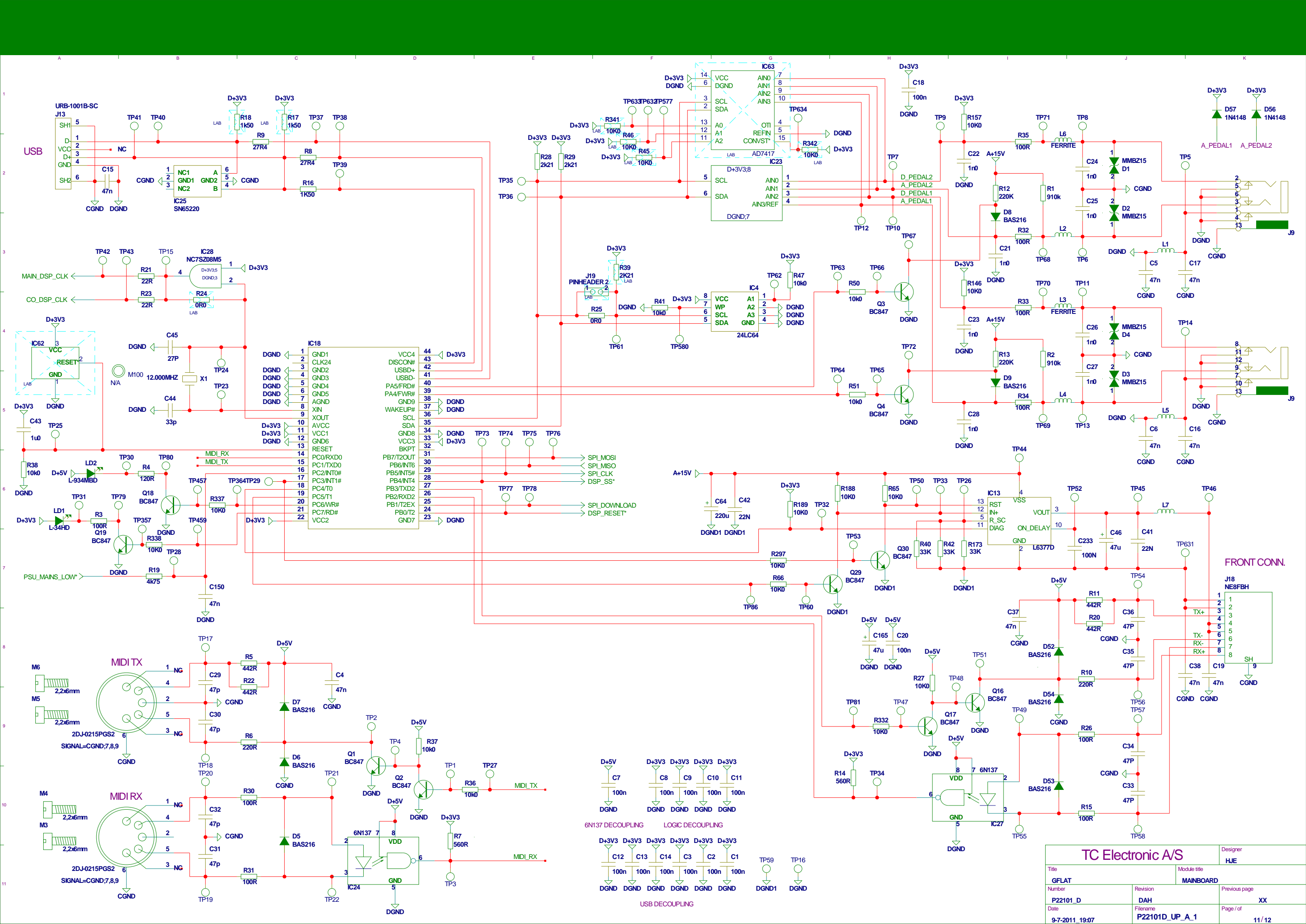

TC Electronic A/S		Designer	HJE
Title	GFLAT	Module title	MAINBOARD
Number	P22101_D	Revision	DAH
Date	9-7-2011 19:07	Filename	P22101D_UP_A_1
		Previous page	XX
		Page / of	11 / 12

SMPS - CONNECTIONS

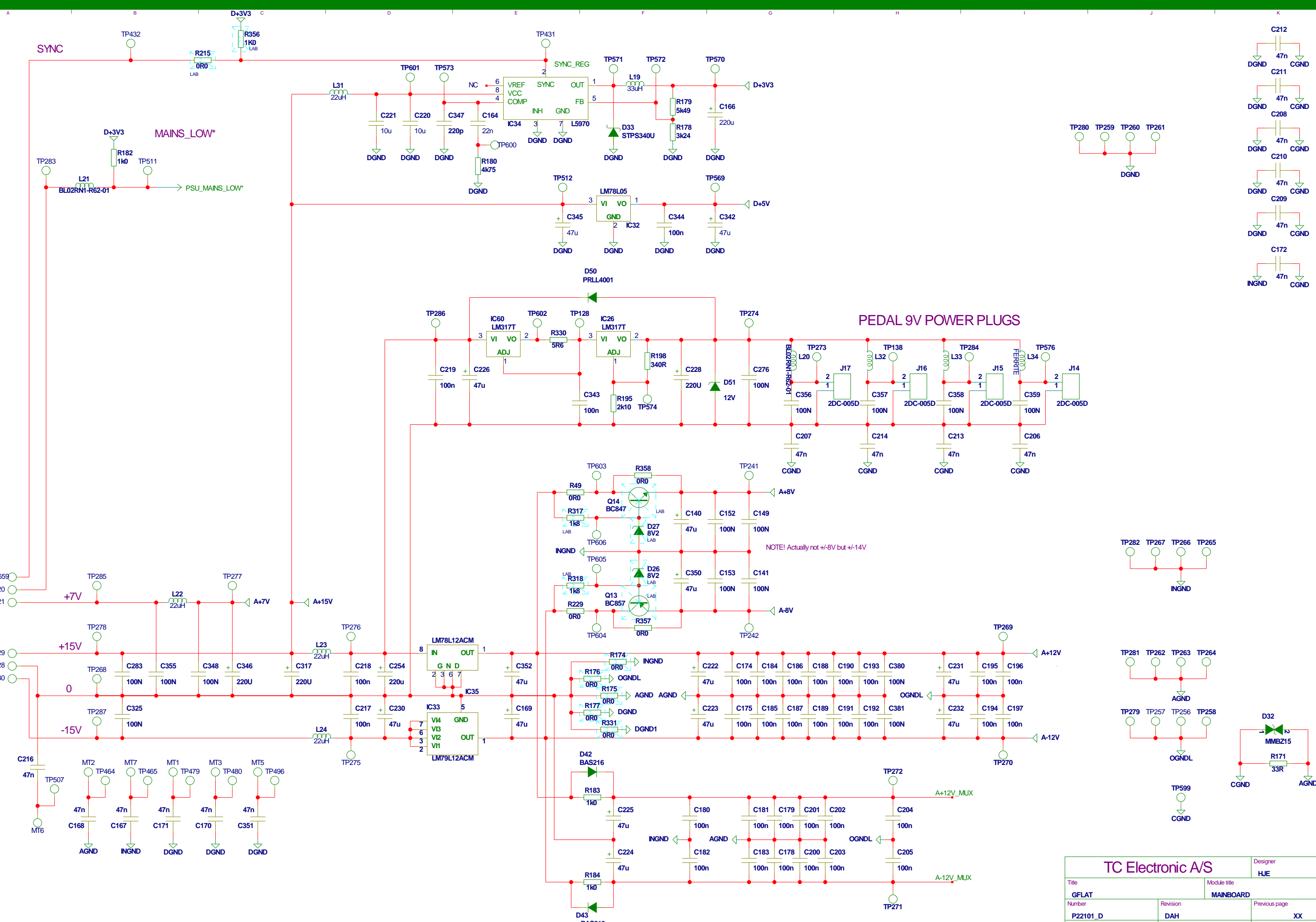

PEDAL 9V POWER PLUGS

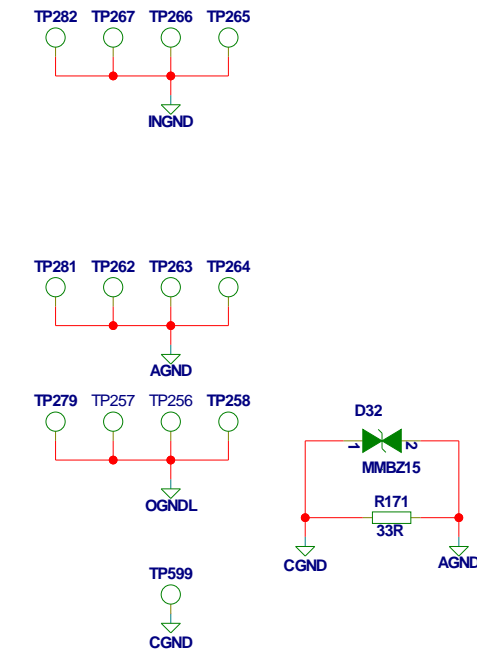
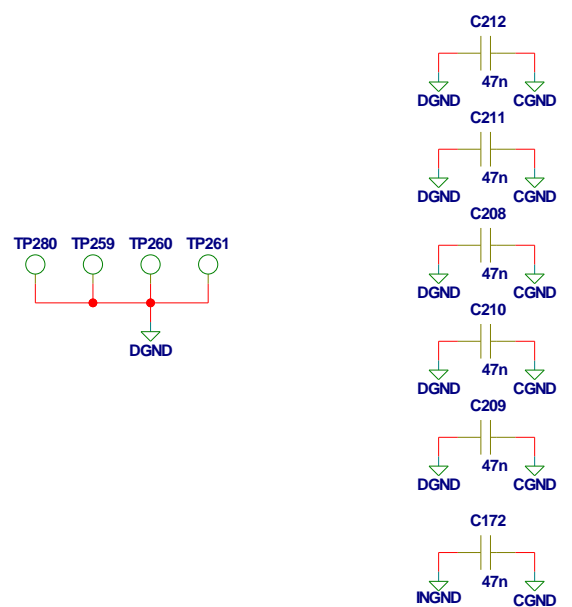

TC Electronic A/S		Designer	HJE
Title	GFLAT	Module title	MAINBOARD
Number	P22101_D	Revision	DAH
Date	9-7-2011 19:07	Filename	P22101D_POWER_A_1
		Page / of	XX / 12