

THE SIGNAL FLOW

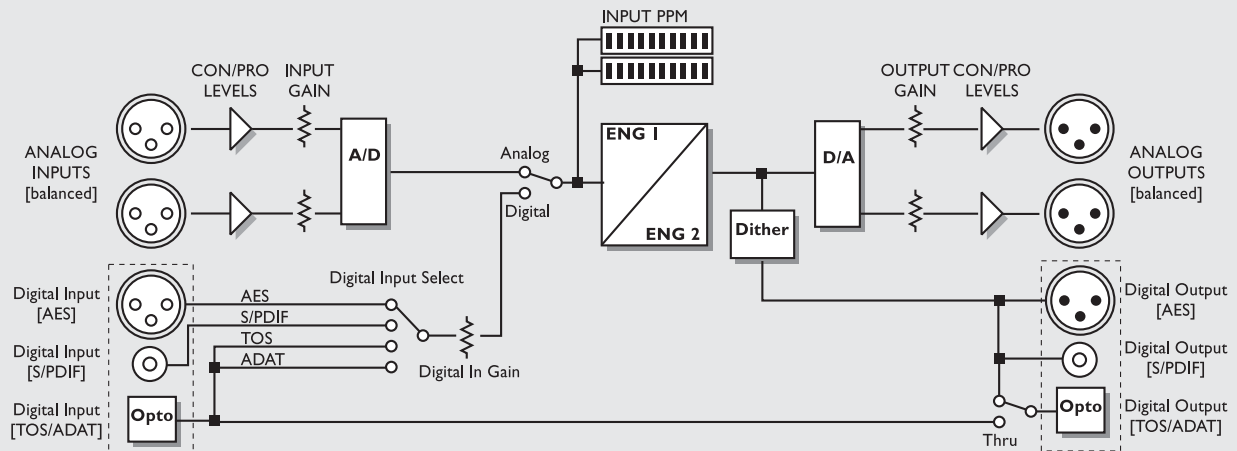

Notes regarding the signal flow:

**As shown in the block diagram signals are present on all Outputs all the time.
You can dither to 22, 20, 18, 16, or 8 bit. (See the I/O section on page 15).**

The Digital Input gain circuit is capable of »lifting« the signal level. This is a very useful feature if you e.g. are feeding the M3000 with a DAT recording that is not fully leveled to 0dB.