

Yukon Mainboard PCB  
M10

<b>TC Electronic A/S</b>		Designer HK_MAR
Title YUKON		Module title BLOCK LEVEL SCHEMATIC
Number P16005	Revision AAC	Previous page XX
Date 9-4-2001 9:44	Filename MAINBOARD	Page / of 1 / 14

Connect to Front

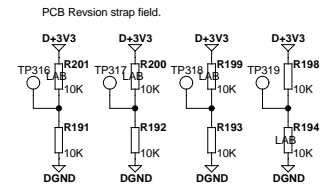
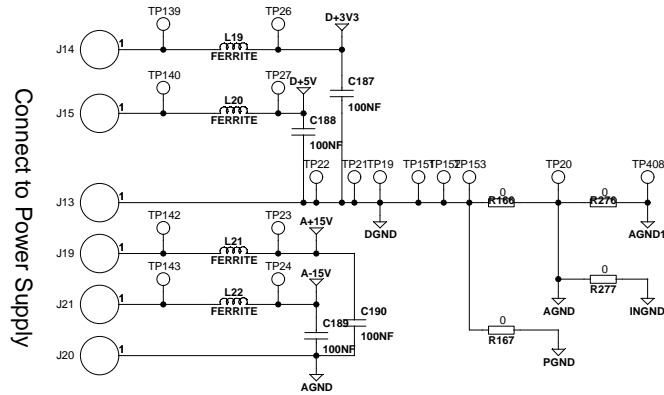
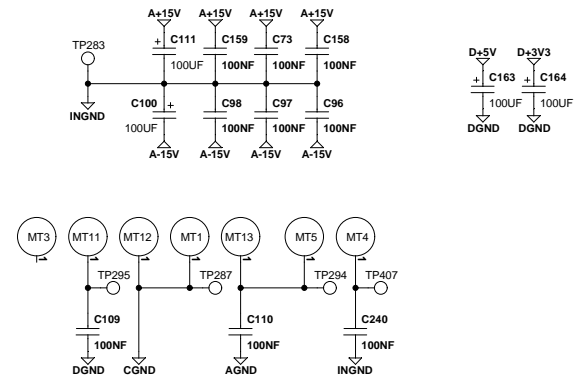
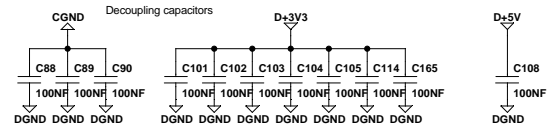
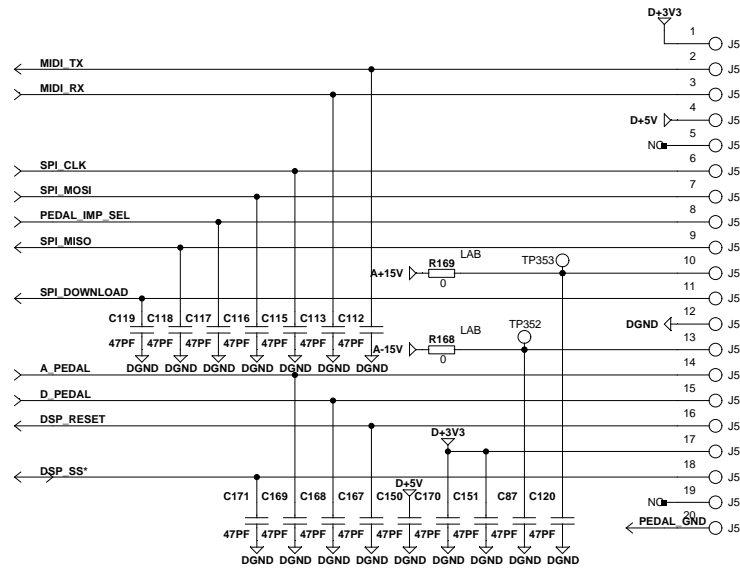

<b>TC Electronic A/S</b>		Designer HK_MAR
Title YUKON		Module title INTERFACE TO FRONT AND POWER
Number P16005	Revision AAC	Previous page 1
Date 9-4-2001 9:43	Filename INTERFACE	Page / of 2 / 14



These devices defines the SRAM on the Partlist

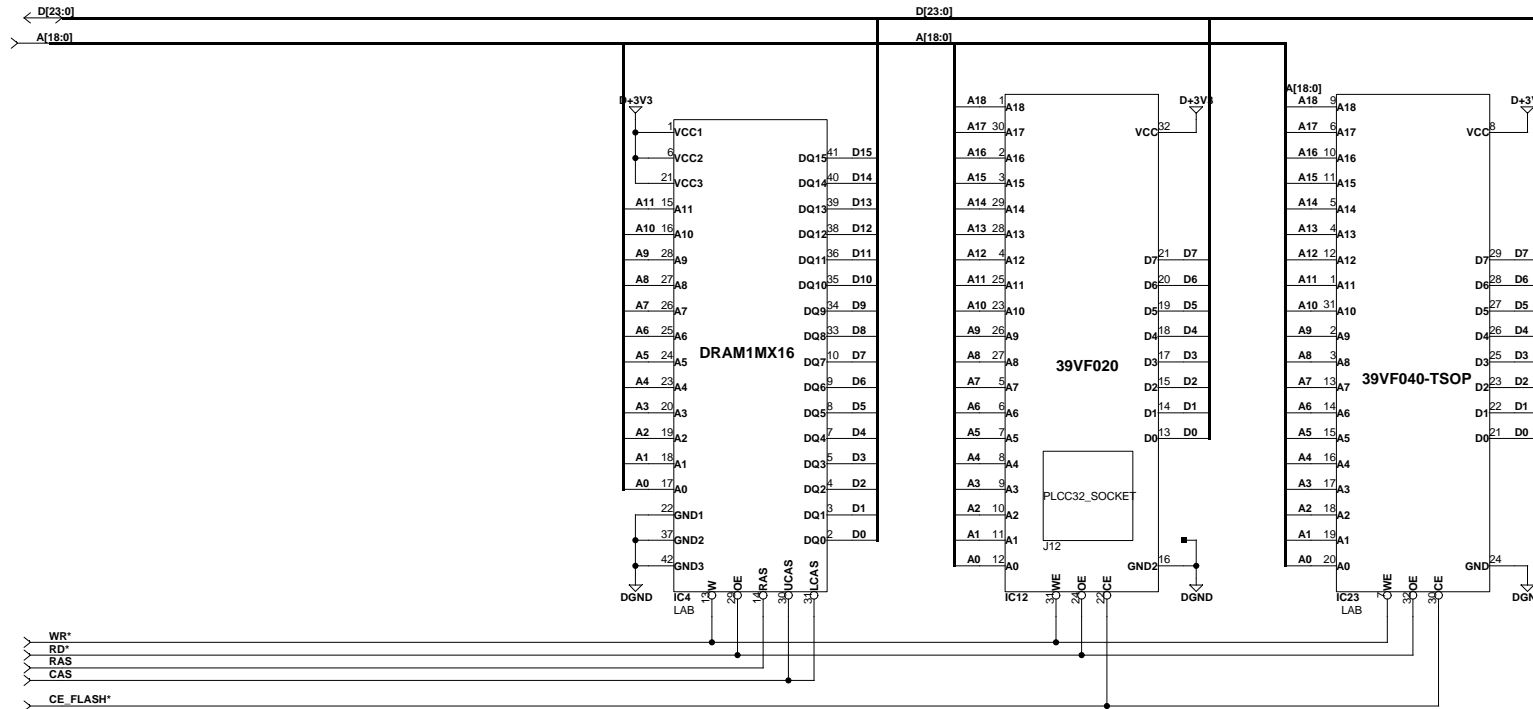
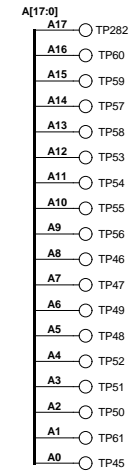
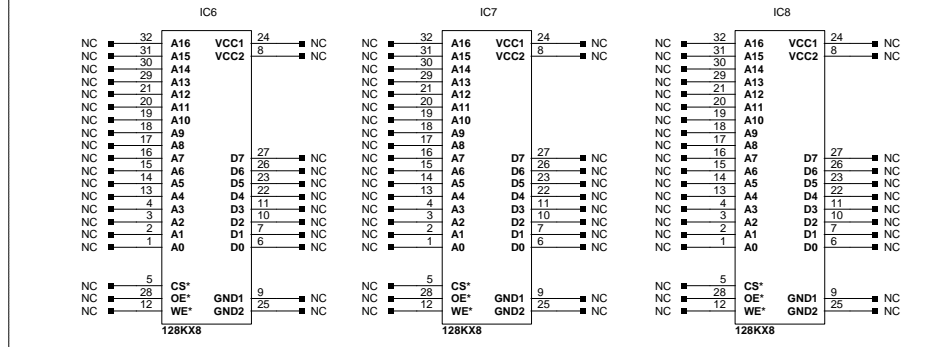

Note: Only one of the Flash types are mounted

TC Electronic A/S		Designer	
Title	YUKON	Module title	HK_MAR
Number	P16005	Revision	MEMORY
Date	9-4-2001 9:44	Filename	MEM
		Previous page	1
		Page / of	4 / 14

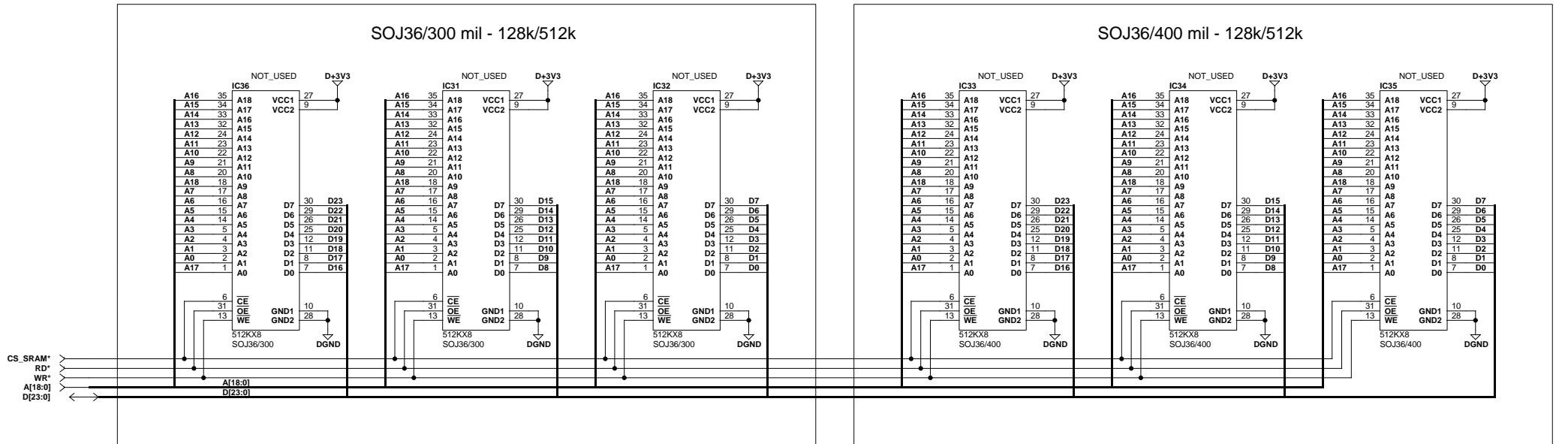

These SRAM devices defines the PCB layout

TC Electronic A/S		Designer
Title	YUKON	HK_MAR
Module title	MEMORY - ALT PACKAGE	
Number	Revision	Previous page
P16005	AAC	1
Date	Filename	Page / of
9-4-2001 9:44	MEM	5 / 14

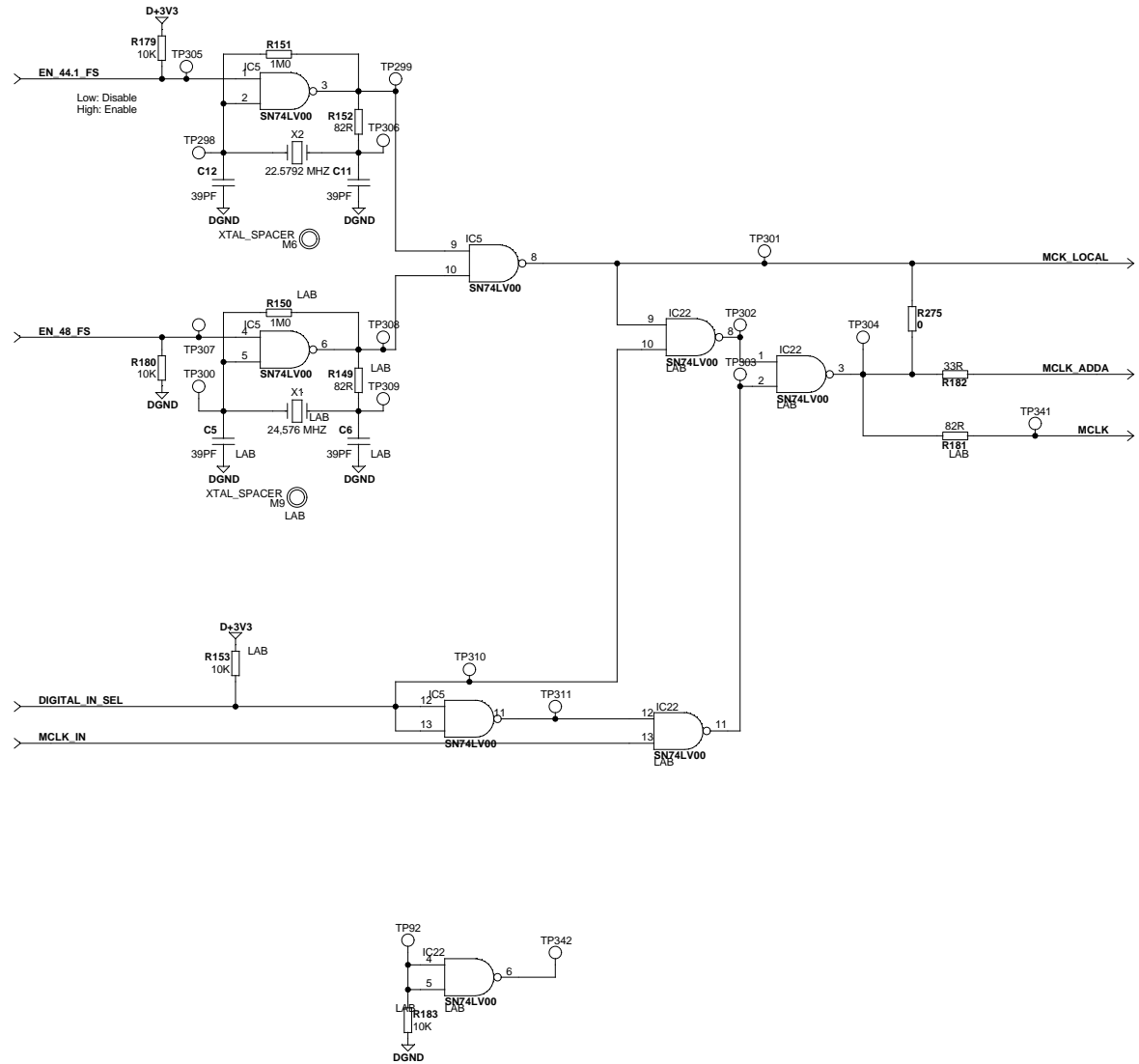

TC Electronic A/S		Designer
Title	YUKON	HK_MAR
Module title	CLOCK	
Number	Revision	Previous page
P16506	AAC	1
Date	Filename	Page / of
9-4-2001 9:41	CLOCK	6 / 14

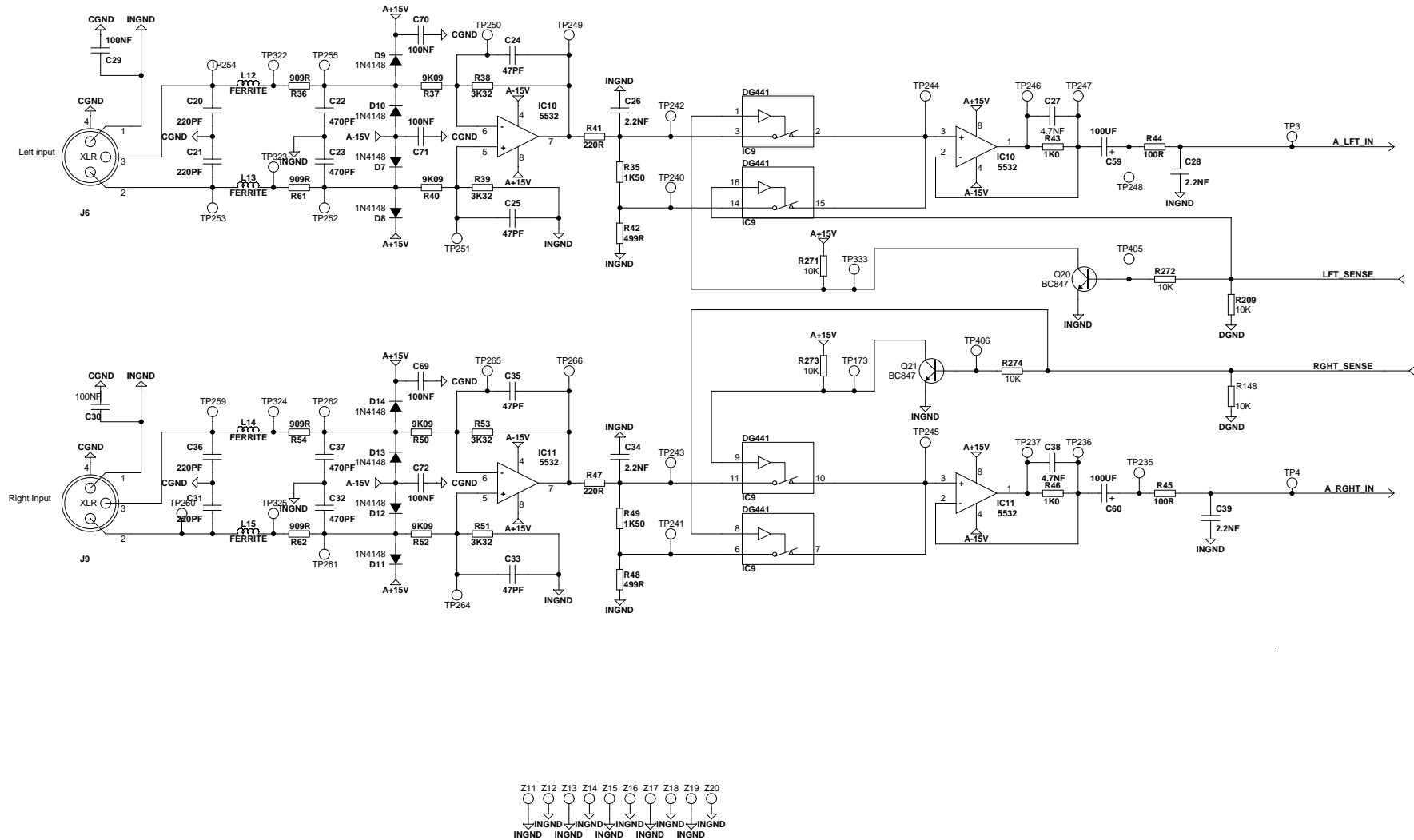

<b>TC Electronic A/S</b>		Designer HK_MAR
Title YUKON		Module title ANALOG INPUT
Number P16005	Revision AAC	Previous page 1
Date 9-4-2001 9:41	Filename ANALOG_IN	Page / of 7 / 14





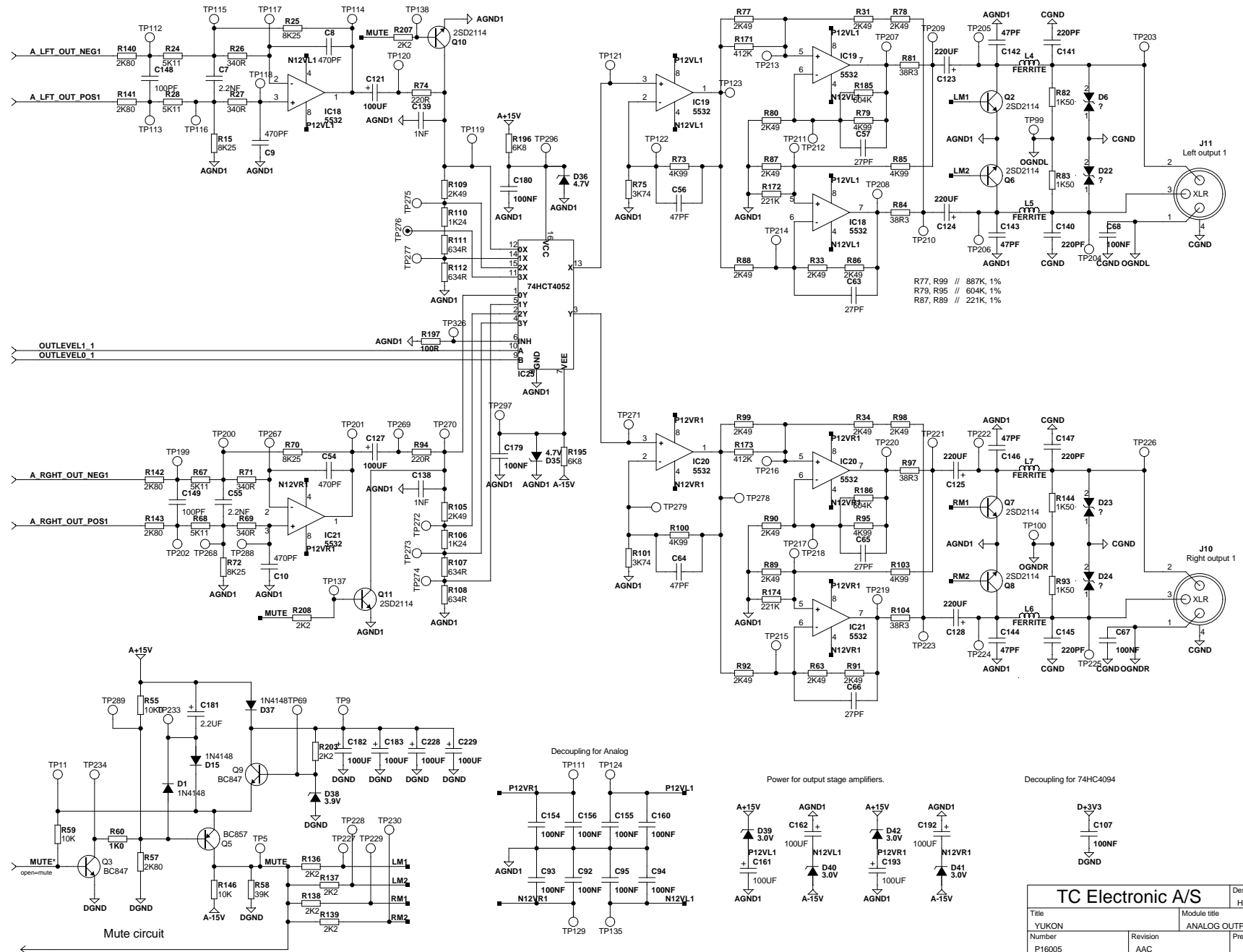

TC Electronic A/S		Designer
Title	YUKON	HK_MAR
Module title	ANALOG OUTPUT 1	
Number	P16005	Revision
Date	9-4-2001 9:42	Filename
Page / of	9 / 14	Previous page
		Page / of

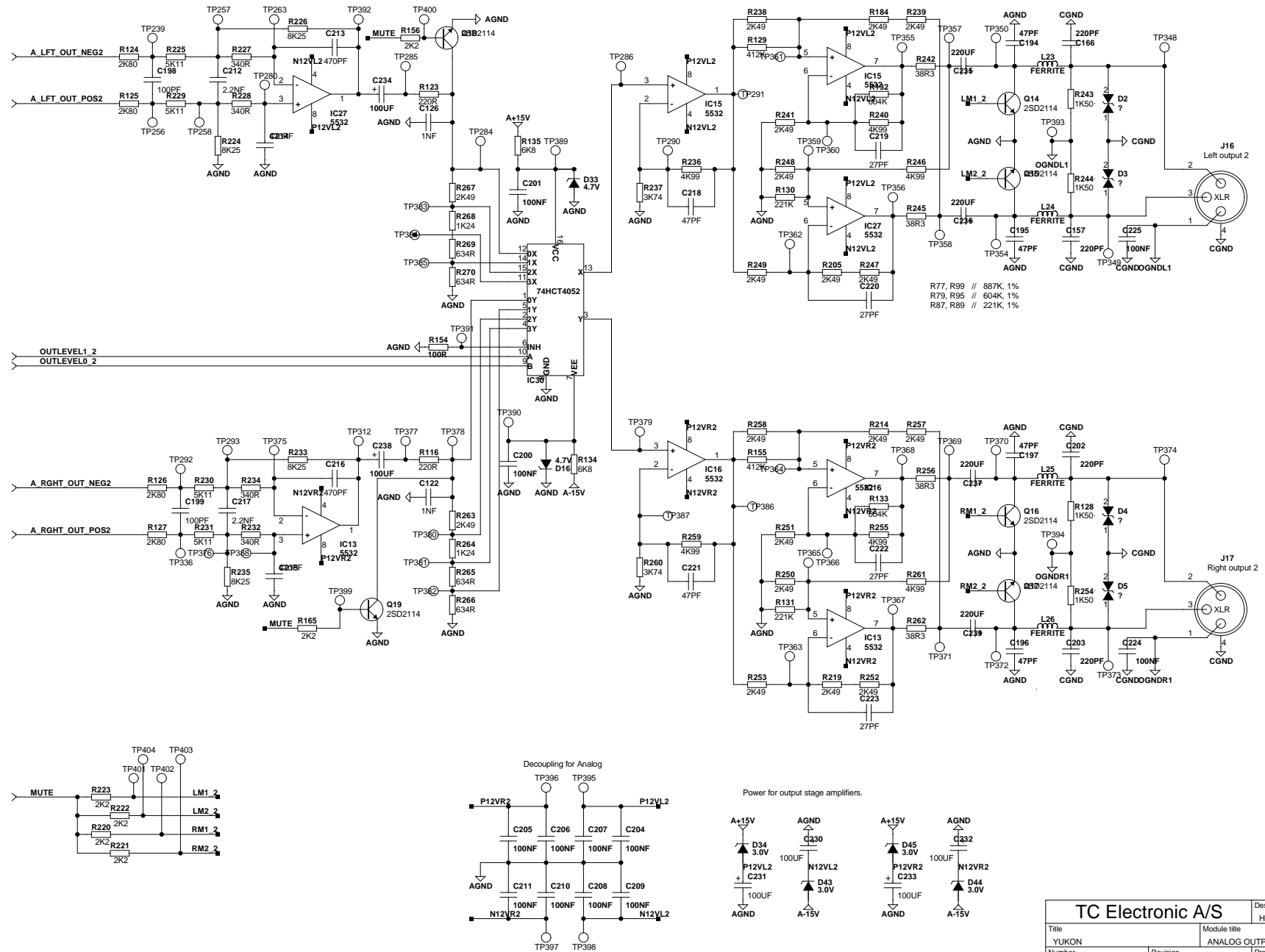

<b>TC Electronic A/S</b>		Designer HK_MAR
Title YUKON		Module title ANALOG OUTPUT 2
Number P16005	Revision AAC	Previous page 1
Date 9-4-2001 9:43	Filename ANALOG_OUT2	Page / of 10 / 14

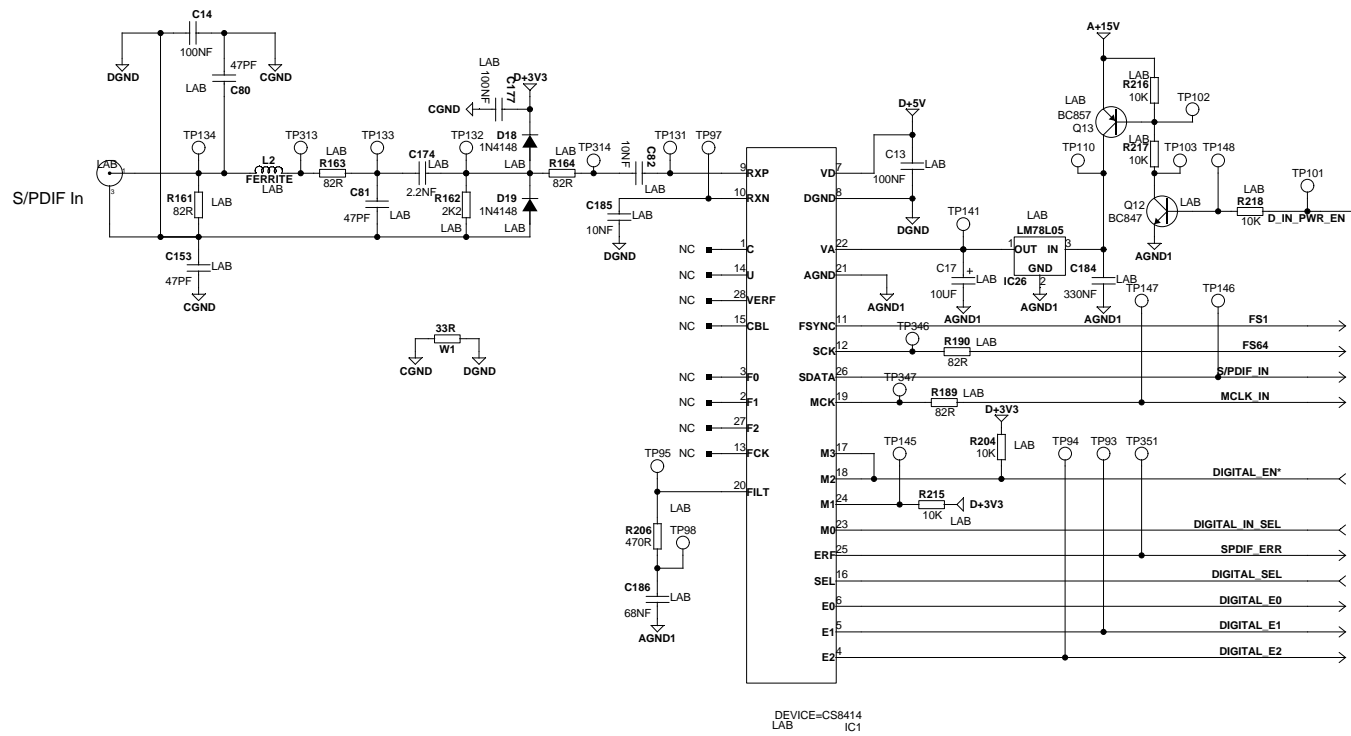

TC Electronic A/S		Designer
Title	YUKON	HK_MAR
Module title	DIGITAL INPUT	
Number	Revision	Previous page
P16005	AAC	1
Date	Filename	Page / of
9-4-2001 9:44	DIGITAL_IN	11 / 14

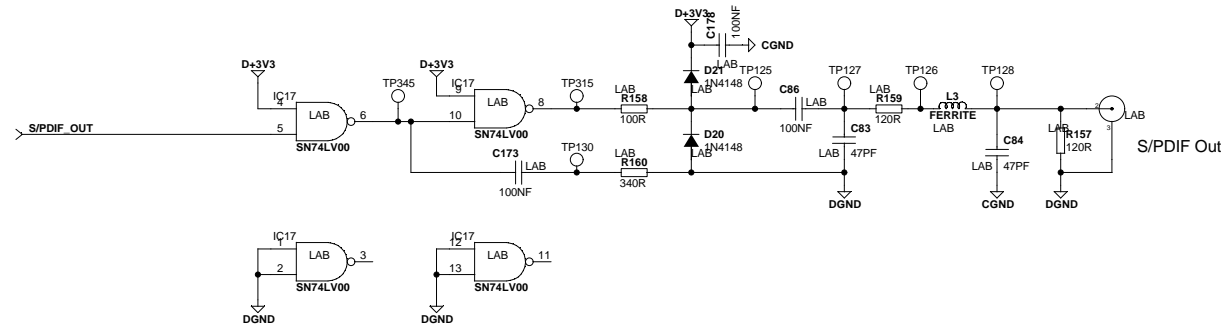

<b>TC Electronic A/S</b>		Designer HK_MAR
Title YUKON		Module title DIGITAL OUTPUT
Number P16005	Revision AAC	Previous page 1
Date 9-4-2001 9:43	Filename DIGITAL_OUT	Page / of 12 / 14

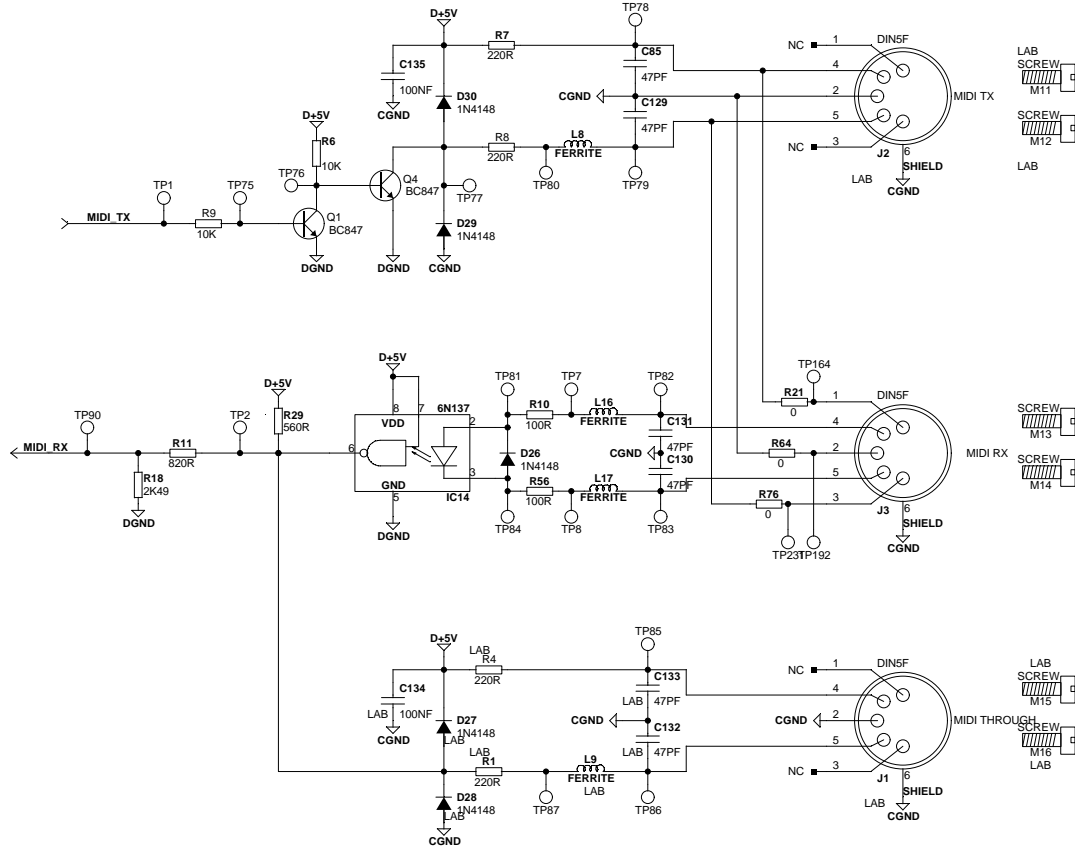

<b>TC Electronic A/S</b>		Designer HK_MAR
Title YUKON		Module title MIDI INTERFACE
Number P16005	Revision AAC	Previous page 1
Date 9-4-2001 9:43	Filename MIDI	Page / of 13 / 14

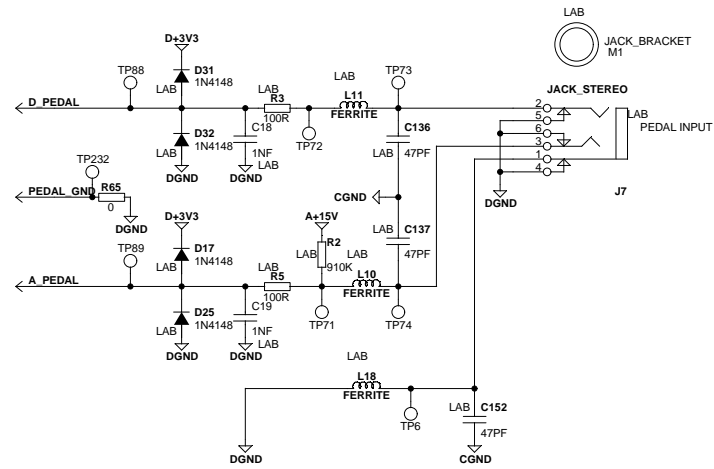

<b>TC Electronic A/S</b>		Designer HK_MAR
Title YUKON		Module title PEDAL INTERFACE
Number P16005	Revision AAC	Previous page 1
Date 9-4-2001 9:43	Filename PEDAL	Page / of 14 / 14