



BUILT FOR POWERCORE



FABRIK C

CHANNEL STRIP PAR EXCELLENCE

t.c. electronic
ULTIMATE SOUND MACHINES

TC Support Interactive

The TC Support Interactive website www.tcsupport.tc is an online support and information center. At the site you can find answers to specific questions regarding TC software and hardware. All known issues are stored in a database searchable by product, category, keywords, or phrases. Under the section "My Stuff" you can login to check the status of your questions, download materials such as product manuals, software updates and new presets.

This site has been specifically designed to meet the needs of our users. We constantly update the database and you will find the site to be a huge resource of information. Browse through Q&A's and discover new aspects of your TC product.

If you can't find an answer online, you have the option of submitting a question to our technical support staff who will then reply to you by e-mail. The TC Support Team is on constant alert to help you in any way they can.

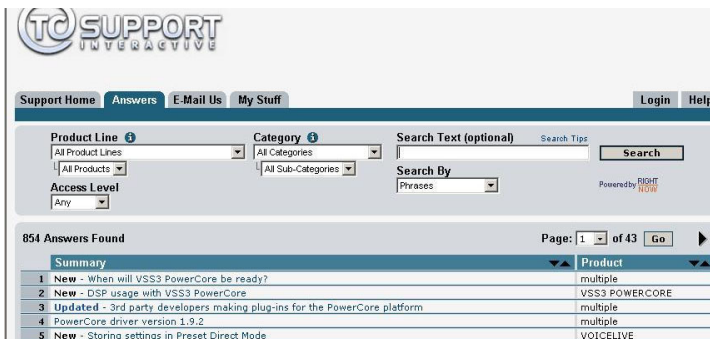

The screenshot shows the TC Support Interactive website interface. At the top is the logo "TC SUPPORT INTERACTIVE". Below it are navigation tabs: "Support Home", "Answers", "E-Mail Us", "My Stuff", "Login", and "Help". The main search area includes dropdown menus for "Product Line" (All Product Lines), "Category" (All Categories), and "Access Level" (Any). There is a "Search Text (optional)" field, a "Search" button, and a "Search By" dropdown set to "Phrases". A "Powered by RIGHT NOW" logo is visible. Below the search area, it says "854 Answers Found" and "Page: 1 of 43" with a "Go" button. A table lists the search results:

Summary	Product
1 New - When will VSS3 PowerCore be ready?	multiple
2 New - DSP usage with VSS3 PowerCore	VSS3 POWERCORE
3 Updated - 3rd party developers making plug-ins for the PowerCore platform	multiple
4 PowerCore driver version 1.9.2	multiple
5 New - Storing settings in Preset Direct Mode	VOICELIVE

Contact Details

Alternatively, you may contact the TC Electronic distributor in your area, or write to:

TC ELECTRONIC A/S
Customer Support
Sindalsvej 34
Risskov DK-8240
Denmark

USA:
TC Electronic, Inc.
5706 Corsa Avenue, Suite 107
Westlake Village, CA 91362
www.tcelectronic.com

© BY TC ELECTRONIC A/S 2006. ALL PRODUCT AND COMPANY NAMES ARE TRADEMARKS OF THEIR RESPECTIVE OWNERS. VST IS A TRADEMARK OF STEINBERG AG, AUDIO UNITS IS A TRADEMARK OF APPLE COMPUTER, INC. ALL SPECIFICATIONS SUBJECT TO CHANGE WITHOUT NOTICE. ALL RIGHTS RESERVED. TC ELECTRONIC IS A TC GROUP COMPANY.

Table of Contents

Contact & Support Information	2
Table Of Contents	3
System Requirements	4
Getting Started	4
Introduction	5
Overview	6
Full-band or 3-band compression	7
Signal Flow	8
EQ Section	9
Filter Types	10
Compression 3-band mode :	
Source page	12
Gain page	12
Compression page	13
Level page	13
Compression Full-band mode	14
Parameter adjust - compression pages	14
The Limiter	15
De-Esser	15
Preset Management	16
A/B Compare function	18

System Requirements

Mac

Desktop, iBook or PowerBook
G4 or G5, 733MHz or better
MacOS 10.3.6 or higher
512 MB Ram or more

PC

Desktop or laptop
Pentium 4, 1.4 GHz or better
Windows XP or higher
512 MB Ram or more

Works with all PowerCore devices

VST, Audio Units or RTAS*) compatible application such as Logic, Nuendo, Live or Digital Performer

*) RTAS (Pro Tools) is supported via the VST to RTAS adapter from FXpansion (optional).
More info on www.tcsupport.tc.

Getting Started

Scroll Wheel Support

If you are using a host application that supports this feature, all parameters support scrolling on both Windows XP and Mac OS X. Simply place the mouse over a parameter value field and use the Scroll Wheel to increment/decrement the associated parameter-value.

Key Commands

In most host applications, Plug-Ins support keyboard commands for certain functions. The following key commands are available for all Plug-In parameters:

Key Commands in Mac OS

Fine Adjust	= Apple
Reset To Default	= Alt
Context Key	= Control + Mouse Button

Key Commands In Windows

Fine Adjust	= Alt
Reset To Default	= Shift & Control
Contextual Menu	= Right Mouse Button

Introduction

Congratulations on the purchase of your Fabrik C plug-in. Fabrik C is based on the innovative Meta Intuitive Navigation Technology (MINT™) that redefines the way you use professional audio plug-ins for professional results. We have integrated a simple yet highly effective and intuitive approach to working with audio, and the result is a user-interface with few handles that are effective but simple to use. Often people think that if you want to create professional results the process has to be tedious and complex – we don't agree. The Fabrik plug-ins introduce a new way of working with audio, and they build on proven and award-winning TC technology, ensuring the highest level of audio quality.

Fabrik C is a full-blown channel strip plug-in with EQ, De-Esser, 3-band Compressor and Limiter in one single plug-in. With MINT™ you have total control of all the parameters, using only a few dedicated knobs. The EQ section is a 4-band parametric EQ with high/low-pass filters – choose between 4 different filter types. Based on no-nonsense design, the De-Esser is controlled using on a single fader.

With a built in 3-band intelligent compression technique the Compressor is not just one of the best compressors available, - it also gives you the means to avoid bad side effects compared to traditional compression. Combined with the Limiter the compression section can be used in a musical way without worrying about overshoots.

With MINT™ you don't need to read a lengthy manual to get going – just use your ears.

Main features

- Novel UI design – built-in MINT™ (Meta Intuitive Navigation Technology)
- Three main sections with TC technology: EQ, de-esser and compressor
- Intuitive and easy control over dedicated parameters – Instant gratification
- 4-band parametric EQ
- Scalable de-esser
- 3-band/full band compressor
- Limiter
- Control many parameters with few knobs
- Based on proven and award winning TC Technology
- Windows XP and Mac OS X support
- VST, AU and RTAS* support
- 24/96 supported
- 48 bit double precision

Overview

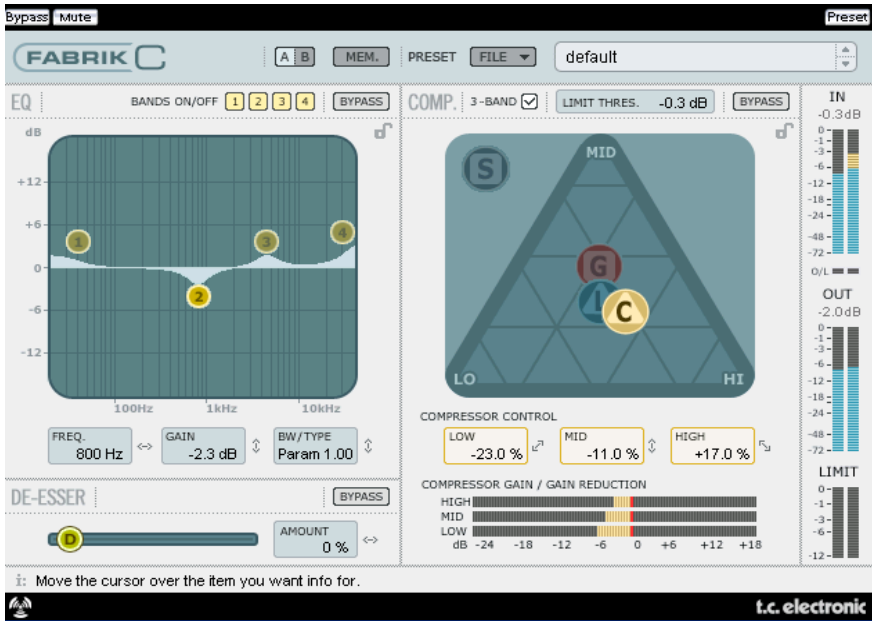

Full-band or 3-band compression?

Fabrik C includes both a 3-band and a Full-band compression mode. As Fabrik C is a plug-in that is designed to be used on single sources and not as a dedicated mastering tool you might wonder how the 3-band mode applies.

An overall “rule of thumb” is that if you are working with a source that has a wide frequency range with large peaks in specific frequency areas, you are most likely best off using the 3-band mode. If on the other hand you’re working with audio that is within a small frequency area, such as e.g. a trumpet section or background vocals, you can with great advantage use the Full-band mode.

Let us look at a few specific application scenarios to give you an idea of what can be achieved with the different compression styles.

3-band compression on Bass

If you were to do a 3-band compression on a bass, this would allow the higher frequencies to pass through, while adding compression to lower frequencies. What this gives you is better control and longer sustain, and a more punchy bass with all the overtones intact.

3-band compression on grouped sources

If you have grouped several sources and want to do a “global” compression on this section, the 3-band mode can be very effective. It will give you more transparency in your overall mix as you can do independent compression to each of the three frequency bands.

Full-band compression on vocals

You probably know that “in-your-face” kind of airy vocal that you hear on some tracks? The way to get that effect is by using a full-band compressor on you vocal track, slowing the attack time, and speeding up the release time. It’s pretty simple when you know how to do it.

Full-band compression on Guitar

It’s amazing how some tonal instruments can get a very percussive quality to them when the right type of effect is applied. Using a full-band compressor on a rhythm guitar will give you a sound that is sharp, sweaty, funky and really emphasizes the rhythmic and percussive qualities of your track.

Limiter

The Limiter is used to prevent overloads occurring at extreme and occasional peaks in the source material, - peaks that may not be caught and attenuated sufficiently in the Compressor. As the Limiter can be used to limit the extreme, the Compressor can be used to apply a much more “musical” and gentle compression.

EQ Section

The Fabrik C EQ section is a 4-band parametric EQ that gives you full control over high- and low-pass filters. Four filter types are available offering Notch, Parametric, Shelving and Cut. If you are looking for a razor sharp filter, use the Notch filter which has a range as low as 0.01 of an octave. For a more gentle approach go for the shelving filter that sports a variable slope with a range from 3dB/oct over 6 and 9 to 12dB/oct. The Cut filter can be switched between a flat amplitude maximum of 12dB to an octave, and a flat group delay type. For a natural and “well behaved” bandwidth, apply the parametric EQ.

De-Esser

A De-Esser is a compressor type used to reduce only specific sibilant frequencies. Typically the “s” sounds can be far too dominant in a vocal track and the track would therefore often benefit from being processed by a De-Esser.

Headroom

To avoid internal clipping and secure ease of use, all processing is done in the 48 bit domain, and is not truncated to 24 bit before the output of the Limiter.

Signal Flow - 3-band mode

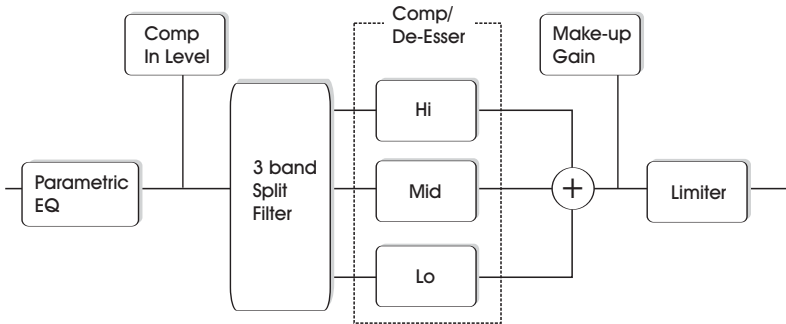

This is a schematic overview of the signals flow through the algorithm in 3-band mode. As illustrated - the signal first passes the 4 band parametric EQ. Then the signal is split into lo-, mid- and hi-bands for individual compression. Cross-over frequencies between the bands are set by the selected Source type. After the Make-up Gain section, the signal passes the Limiter.

Signal Flow - Full-band mode

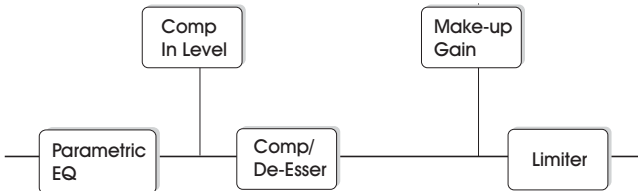

The signal flow in Full-band mode is similar to 3-band mode. The difference lies solely in the Full-band compression as opposed to the split-filter and 3 compression bands found in 3-band mode.

EQ section

The Fabrik C EQ section is a 4-band parametric EQ with four selectable filter types: Notch, Parametric, Shelving and Cut. If you're looking for a razor sharp filter, use the Notch filter that has a range as low as 0.02 octaves. For a more gentle approach the shelving filter with a variable slope is a better choice. Cut filters can be switched between a 12dB/oct maximum flat amplitude (Butterworth) and a flat group delay type (Bessel). Mark the handle (1, 2, 3 or 4) for the band to adjust. Set the BW/Type, then grab the handle again and move for frequency/gain adjustments.

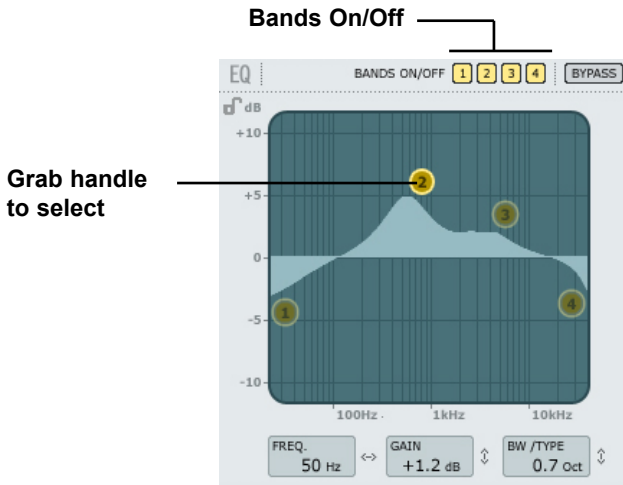

Bands On/Off

Click to activate/deactivate the four individual bands.

Adjusting Frequency and gain

Simply grab the symbol for one of the active bands (1, 2, 3 or 4) using the left mouse button and move until desired settings are achieved.

Adjusting BW/TYPE

First select a band. Then place the cursor within the BW/Type field, press left mouse button and move mouse up/down to change type and bandwidth. Different types of filters are available for the Low, Mid and High filters. Please refer to the following pages for overview of the EQ types.

Bypass

Press to bypass the EQ section.

Filter types

For Lo and Hi filters select between filter types: Parametric, Notch, Shelf and Cut.

For Mid 1 and Mid 2, select between filter types: Parametric and Notch.

Parametric Filter - Broad type

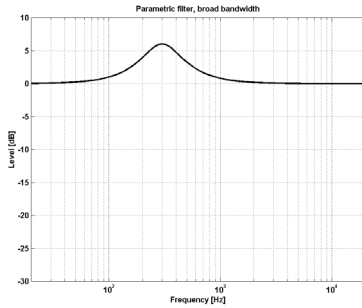

Shelving Filter

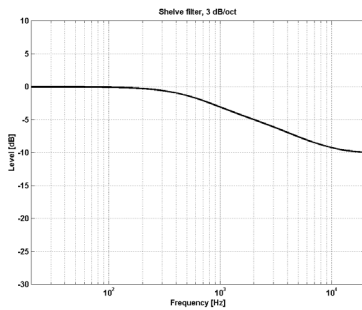

Notch Filter - Narrow type

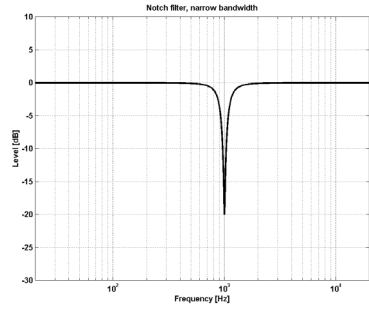

Cut Filter - Bessel type

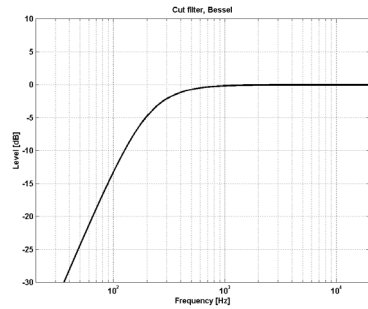

Cut Filter - Butterworth type

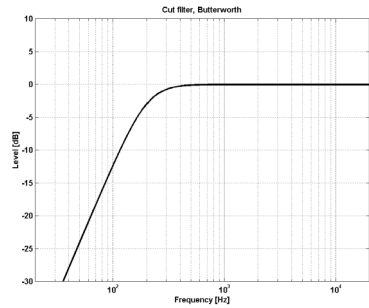

Type

Range for the Notch filter:

Lo Gain : -inf; -97dB to 0dB
Mid1 Gain : -inf; -97dB to 0dB
Mid2 Gain : -inf; -97dB to 0dB
Hi Gain : -inf; -97dB to 0dB

Range for the Notch filter:

Lo BW : 0.02oct to 1oct
Mid1 BW : 0.02oct to 1oct
Mid2 BW : 0.02oct to 1oct
Hi BW : 0.02oct to 1oct

Range for the Parametric filter:

Lo BW : 0.1oct to 4oct
Mid1 BW : 0.1oct to 4oct
Mid2 BW : 0.1oct to 4oct
Hi BW : 0.1oct to 4oct

Range for the Shelve filter:

Lo BW : 3dB/oct to 12dB/oct
Hi BW : 3dB/oct to 12dB/oct

Range for the Cut filter:

Lo BW : Bessel or Butterworth
Hi BW : Bessel or Butterworth

Bandwidth/Q - Key-Values:

BW		Q
0.5	-	2.87
0.7	-	2.04
1.0	-	1.41

Freq

Range - Lo band : 20Hz to 20kHz
Range - Mid1 band : 20Hz to 20kHz
Range - Mid2 band : 20Hz to 20kHz
Range - Hi band : 20Hz to 40kHz

Gain

Select the band, click on the Gain field then drag the mouse vertically to change the value.

Range for the Parametric, Shelve and Cut type:

Lo Gain : -12dB to +12dB
Mid1 Gain : -12dB to +12dB
Mid2 Gain : -12dB to +12dB
Hi Gain : -12dB to +12dB

Compression

3-band and Full-band modes

Source page



Source Selection

Use the Source page to select which type of material you are processing.

- Grab the “S” and move the symbol in vertical and horizontal directions to select the source-type best matching your source material.

Each type selects a carefully tuned combination of the essential compression parameters: Attack, Release, Threshold and Ratio.

For Vocals:

Female Vocal, Male Vocal, Speak, Choir

For Instruments:

Guitar, Piano, Horns, Bass

For Percussive material:

Kick, Snare, Perc, Kit

For full-range material:

Mix Rock, Mix soft, Mix Acoustic, Mix Purist

Compression

3-band and Full-band modes

Gain page

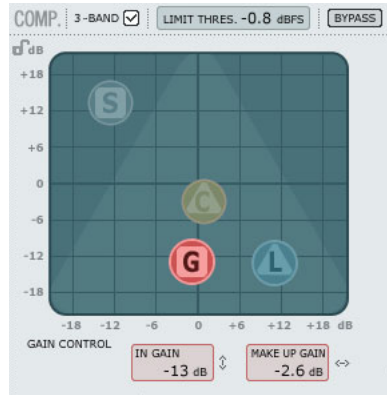

Gain Control

The Gain settings are very important. The higher set In Gain the harder the signal meets the Compressor Threshold.

- Grab the “G” and move the symbol in vertical and horizontal directions to set both In Gain and Make up gain with just one handle.

The Threshold is automatically set when the Source type is selected, however, the Gain parameters determine how hard the signal meets the Threshold.

Depending on how the Compressor parameters are set, the level will change. The Make Up Gain parameter is used to compensate for this level change.

In Gain Range: -18 to +18dB

Make Up Gain: -18 to +18dB

Compression

3-band mode only
Compressor Control page



Compressor control

The Low, Mid and High parameters indicate the set compression amount for the three bands.

- Grab the “C” and position this handle freely within the triangle to distribute the amount of compression on the three bands.

If the compression should primarily be on the low end frequencies move “C” in that direction. Likewise with the Mid en High areas.

Where the Gain parameter is used to gain the input of the Compressor and also set the Make-up gain on the output, the Compression Control adjusts the individual compression amount on the three bands.

Compression

3-band mode only
Level page

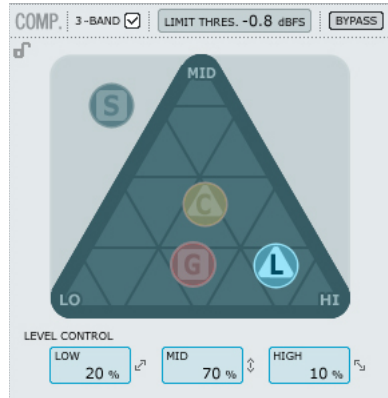

Level Control

Depending on the amount of applied compression you may need to level compensate the three individual bands.

- Grab the “L” and position this handle freely within the entire triangle.

Where the Make-up Gain function on the Gain page is used as a general level compensation on the entire signal, the Level control can be used to set the level for the three bands individually.

Compression

- Full-band mode

The Compressor is in Full-band mode when “3-band” is not marked.



In 3-band mode the Compression Control “C” and the Level Control “L” handles the distribution of compression and Level between the 3 bands.

In Full-band mode these controls are redundant and not available.

In Full-band mode only Source select “S” and Gain “G” applies.

See pages 6-7 for application examples of the Full-band mode.

Parameter adjust - Compressor section

As described in the previous section the parameters on the 4 Compression pages are adjusted simply by grabbing and moving the “S”, “G”, “C” and “L” handles - however, a few extra cool features are also available.

Grid

On the Source pages the “S” handle moves in vertical and horizontal directions only, but on the Compression Control, Level and Gain pages the “C”, “L” and “G” handles move freely in all directions. You may, however, see the advantage of moving the handle in one direction only. Therefore it is possible to lock a direction in a “grid”.



- Grab the handle C, L or G handles using the left mouse button.
- Press and hold the Alt key while moving the mouse in a circle. The “compass” function is now active and you can select one of 2 to 6 directions.
- Release the Alt key and move the mouse still holding the left mouse button pressed to select desired values.
- Release mouse button to release the grid.

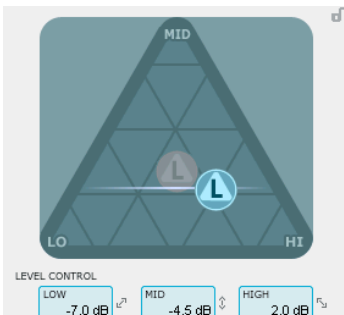

The Limiter

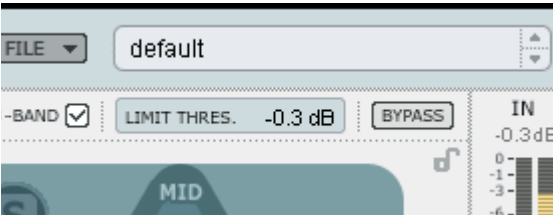

Fabrik C also holds a Limiter. The Limiter is used to prevent overloads occurring at extreme and occasional peaks in the source material, - peaks that may not be caught and attenuated sufficiently in the Compressor. As the Limiter can be used to limit the extreme, the Compressor can be used to apply a much more “musical” and gentle compression.

Threshold

Range: -12dB to 0dB

The Threshold sets the max amount allowed to pass through the Limiter.

We recommend a setting of -0.1dB as maximum.

De-Esser

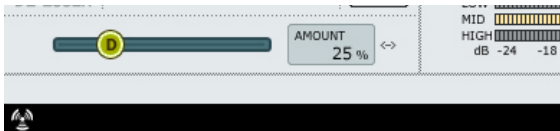

A De-Esser is a compressor type used to reduce only specific sibilant frequencies. Typically the “ss” sounds can be far too dominant in a vocal track and the track would therefore often benefit from being processed by a De-Esser.

The De-Esser also comes in handy when working with background vocal tracks with many voices dubbing the “s”-sounds from the lead track.

The De-Esser works in both 3-band and Full-band modes.

Bypass

Use Bypass to activate or deactivate the De-Esser.

Amount

Range: 0 to 100%

Move the slider from left to right while listening to set appropriate amount of de-essing. A De-Esser reduces certain high-end frequencies and you should not set the Amount parameter higher than necessary.

Preset Management

Fabrik's comprehensive file based preset architecture makes archiving presets a simple process. This allows you to organize your presets the way you find most comfortable for your workflow, and to exchange presets with other users. Presets are saved as discrete files on your hard drive. Once a preset is saved into the default location, it will automatically appear in the 'File' menu every time you use the Plug-In. The files can then be organized into sub-folders, where you can delete, rearrange or create your own sub-folders to accommodate your needs. For example, you could create preset folders for projects, customers or by application, such as 'Clean Up'.

NOTE: A folder will not appear in the Preset File Menu unless it has at least one preset inside!

Preset File Menu

Pressing the 'File' button will open the File menu. The following options are available from the File menu.



Loading a Preset

By selecting 'Load', you can navigate to any folder on the system that you have read access to, including any shared folder. By default, these will be loaded from the default location for Fabrik C presets. Only presets located in the default file location will appear in Fabrik C pop-up preset menu.

Saving a Preset

By selecting 'Save', you can save your preset to any folder on the system that you have write access to, including any shared folder. By default, presets are saved to the default location for the Fabrik C presets.

Section-Lock function at recall

It is possible to lock any of the three sections in the plug-in when recalling a preset. This way it is possible to e.g. keep the current EQ setting and only load the De-Ess and Compression settings from the preset you are about to recall.

To lock/unlock

Simply click in the pad-lock symbols in the relevant sections:

Unlocked - Locked



Default Preset Locations

The following locations will describe where you can find the Fabrik C presets, which are stored in a folder unique to each plug-in:

OS X preset paths:

Factory presets:

\Library\Application Support\TC Electronic\Fabrik C\Presets

User presets:

~\Library\Application Support\TC Electronic\Fabrik C\Presets

~ \ Refers to your user folder: Users \ Your Name

WINDOWS preset paths:

Factory presets:

~\TC Electronic\Fabrik C\Presets

User presets:

My Documents\TC Electronic\Fabrik C\Presets

(~ \ Refers to the path for your System Hard Drive \ Program Files)

- To delete a file, simply move it to the 'Trash' or 'Recycle bin'.
- To create a new sub-folder that appears in the Plug-In menu, simply create a new folder in the Plug-In folder that resides in the PRESETS folder of the Fabrik C default preset location.

NOTE: A folder will not appear in the Preset File Menu unless it has at least one preset inside!

Compare settings with A/B and Mem.



A/B

With the A/B compare function you can easily compare different parameter settings when you work with your music.

When you start working with your preset, the A/B button is grayed out. This state indicates that the settings in both memory locations A and B are identical - so there is actually nothing to compare.

As soon as you touch one of the parameters, the memory location "A" will be active, and the "A" will light up. All parameter changes will be applied to memory location "A". If you switch to memory location "B", you go back to the starting point, and all further changes will now be applied to memory location "B".

Every time you press the A/B button, you will toggle between these two memory locations.

NOTE: The A/B memory locations are temporary settings only! Saving a preset (e.g. via the File button or with your session) will only save the currently selected memory location. The setting of the other (hidden) memory location will not be saved!

Mem

The "Mem" button will reset the A/B memory locations to the current setting.